

 **INDUCTIVE SENSORS** **PHOTOELECTRIC SENSORS****A****ADJUSTMENT (POTENTIOMETER)**

The sensitivity is adjusted by means of the built-in single or multi-turn potentiometer (if provided). Turning it clockwise increases the sensitivity. Multi-turn potentiometers cannot be turned over their end position (no stops).

**THROUGH-BEAM SENSORS / REFLEX SENSORS**

The potentiometer is normally set to the maximum sensitivity (turned clockwise). This provides the maximum system reserve (excess-gain) signal. A reduction in sensitivity may only be necessary to detect transparent objects.

**DIFFUSE SENSORS**

Set the sensitivity so that the target is reliably detected; for reliable operation, the green LED should light up, or the yellow LED should not flash (series 1040/1050/0507). On removing the object, if the output remains ON (detection of the background), the sensitivity must be reduced slightly.

**DIFFUSE SENSORS WITH BACKGROUND SUPPRESSION**

The setup must ensure that the target is clearly identified, and any background excluded. The target should first be positioned at the maximum foreseen distance from the emitter, and the potentiometer adjusted so that the output just switches. The target is then removed and the potentiometer adjusted so that the background just causes the output to switch. Finally, the potentiometer is set to half way between the two previous readings. Where there is no background, the potentiometer should be set to the maximum distance.

**ALIGNMENT****THROUGH-BEAM SENSORS**

First place the receiver and fix it in its final position. Then align the emitter accurately onto the receiver.

**REFLEX SENSORS**

First place the reflector as required, and fix it firmly in place. Cover the reflector all around with adhesive tape so that only the center (approx. 25% of the surface area) remains free. Fit the reflex sensor with the optical axis aligned on the reflector so that it switches reliably. Finally, remove the adhesive tape from the reflector.

**DIFFUSE SENSORS**

Align the unit's optical axis with the target so that switching occurs reliably. Check that enough system reserves (excess gain) are available, i.e. the green LED must light up (series 1120, 1180, 1180W, 3030, 3031, 3060, 4040, 4050, 5050 and 6080), and with the series 1040/1050/0507, the yellow LED should not flash. Finally, fix the device firmly.

**DIFFUSE SENSORS WITH BACKGROUND SUPPRESSION**

Line up the beam on the center of the target, before fixing the device firmly.

## AMBIENT LIGHT LIMIT



Ambient light is that which is produced by external light sources. The illumination intensity is measured on the light incidence surface. The sensors are basically insensitive to ambient light due to the use of modulated light. There is nevertheless an upper limit for the intensity of any external light and this is referred to as the ambient light limit. It is given for sunlight (unmodulated light) and halogen lamps (light modulated at twice the mains frequency). Reliable operation of the units is no longer possible at light intensities above the relevant ambient light limit.

## AMBIENT TEMPERATURE



The specified ambient temperature range **must not be exceeded** in order to avoid damaging the sensor and rendering its performance unreliable.

## ANALOG OUTPUT



Devices with analog output deliver an analog output signal approximately proportional to the target distance. For most models, voltage and current outputs are available **simultaneously**.

## AUTOCOLLIMATION



Photoelectric sensors using the autocollimation principle are characterized by the fact that the optical axes of the emitting and receiving channels are identical. This is possible with light from one of the channels being deflected by means of a semi-transparent mirror (Fig. 17). This principle completely eliminates the interfering blind zone often found in the proximity of the sensor, which is of special advantage when using reflex sensors. Reflex sensors with autocollimation are especially suitable for foil reflectors.

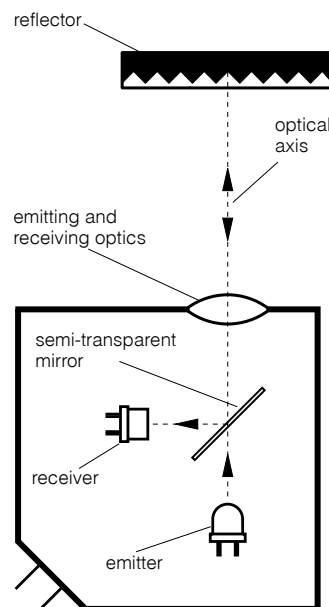

Fig. 17

# B

## BACKGROUND SUPPRESSION



The light pulse from the emitting diode leaves the optical system as a focused, almost parallel, light beam. On meeting an object in its path, part of the beam is diffusely reflected, and in turn, part of this reflected light falls on the PSD (**P**osition-**S**ensitive **D**evice) housed in the same sensor (Fig. 18).

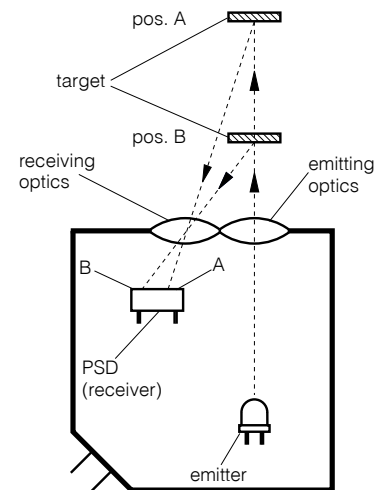

Fig. 18

Depending on the distance of the target from the device, the light falls on a particular spot of the PSD, and a corresponding reception signal is emitted, indicating that an object is present at a certain distance from the device. The analyzing circuit compares the signal received with the preset operating distance (adjusted by means of the built-in potentiometer), and, if the distance of the object is less than, or equal to, the preset operating distance, the output is switched. Contrary to an energetic diffuse sensor, the operating distance depends only to a very small extent on the target's size or color, or on the nature of its surface. The object can therefore be easily discerned, even against a light background. These devices are not suitable for objects having shiny surfaces.

# C

## CAPACITANCE



The maximum switchable capacitance is the greatest permissible total capacitance at the device's output so that **reliable switching** is still guaranteed. Contributing to this total capacitance in particular are the lead capacitance (approx. 100 ... 200 pF per m) and the load's input capacitance. The value is given in the individual data sheets. These can be found on the Contrinex website ([www.contrinex.com](http://www.contrinex.com)), or ordered from our sales offices.

## CE MARK



All sensors in this catalog meet the requirements of European standards EN 60947-1 and EN 60947-5-2, and therefore correspond to EMC directive 2004/108/EC, as well as low-tension directive 2006/95/EC. Consequently, they are labeled with the CE mark.



However, this mark is **neither a quality seal, nor an official test label** certified by any authority. By applying the CE mark, the manufacturer confirms (under his own responsibility) that the protective requirements for the product meet the applicable EU directives, and consequently that the corresponding EU standards have been complied with. The CE mark enables the free importation of goods into the EU, as well as their free circulation within the EU.

## CHANGEOVER



Devices with changeover outputs provide one output for the light-ON or N.O. signal, and another for the dark-ON or N.C. signal. Both functions are available simultaneously for maximum connection flexibility to the control unit. Moreover, logical connections may be implemented without using series connection. Connecting both outputs to the control unit allows for additional security monitoring.

## CLEARANCE



Inductive sensors must not mutually influence each other. For this reason, a minimum distance **A** between devices of diameter **D** must be observed (Fig. 19).

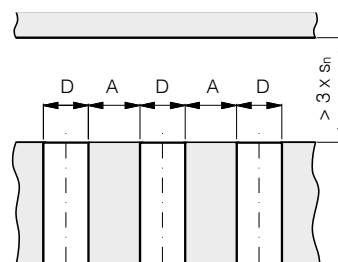

Fig. 19

## SERIES 300, 400, 420, 600, 620\*

Size D	embeddable A (mm)	non-emb. A (mm)
Ø 3	0 / *2	---
M4	0 / *1	---
Ø 4	0 / *1	---
M5	0 / *1	---
C 5	0 / *1	---
Ø 6.5	3 / *3.5	--- / *15.5
M8	2 / *4	10 / *14
C8	2 / *2	---
M12	4 / *12	28 / *33
M18	7 / *22	32
M30	10	50
C44	35	120
C40	35	140
C60	---	120
C80	---	420

## SERIES 500, 520\*

Size D	(quasi)-embed. A (mm)	non-emb. A (mm)
Ø 4	6 (embeddable)	---
M5	5 (embeddable)	---
Ø 6.5	9.5	---
M8	8 / *16	20
C8	8	---
M12	18 / *34	30
M18	26	60
M30	50	120

## SERIES 700

Size D	embeddable A (mm)	non-emb. A (mm)
M8	14	52
M12	38	108
M18	42	182
M30	80	270



Photoelectric sensors must not mutually influence each other. For this reason, a minimum distance "a" between them has to be respected, which depends strongly on the model used and the actual sensitivity setting. The following values should therefore be considered as rough guidelines only. The values given are for maximum sensitivity.

## DIFFUSE SENSORS (FIG. 20)

Series	distance a (mm)
Series 1040 / 50	50
Series 1040 / 50...505	15
Series 1040 / 50...506	30
Series 1120	150
Series 1180 / 1180W	500
Series 3030	500
Series 3031	250
Series 4040	750
Series 4050	150
Series 5050	200
Series 6080	500

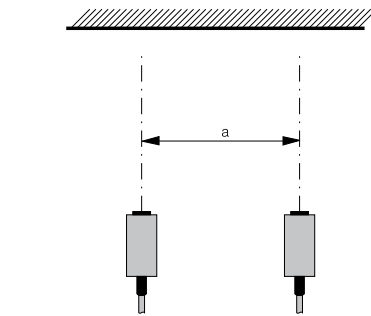

Fig. 20

## DIFFUSE SENSORS WITH BACKGROUND SUPPRESSION

Series	distance a (mm)
Series 1180 / 1180W	50
Series 3130	50
Series 3131	50
Series 4050	100
Series 6080	150

## REFLEX SENSORS (FIG. 21)

Series	distance a (mm)
Series 1120	150
Series 1180 / 1180W	250
Series 3030	500
Series 3031	250
Series 4040	750
Series 4050	200
Series 5050	200
Series 6080	500

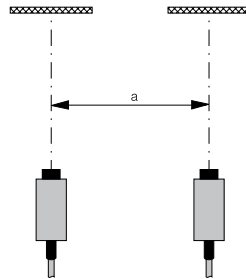

Fig. 21

## THROUGH-BEAM SENSORS (FIG. 22)

Series	distance a (mm)
Series 1040 / 50	50
Series 1120	150
Series 1180 / 1180W	250
Series 3030	500
Series 3031	250
Series 4040	750
Series 4050	500
Series 5050	200
Series 6080	500

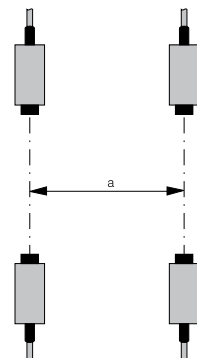

Fig. 22

## FIBER-OPTIC AMPLIFIERS

The value "a" depends strongly on the specific type of fiber used. General recommendations are therefore not possible.

## CONDET® TECHNOLOGY



An innovative technology for producing inductive sensors. Contrary to conventional technology, in which a high-frequency magnetic field is generated in front of the sensing face, here the coil is triggered by an alternating polarity **pulsed current**. This technology is used in the 700 series (see also page 13). It permits:

- generally long operating distances
- long operating distances also on non-ferrous metals, such as aluminum, brass, copper, etc.
- **one-piece** stainless steel housing (sensing face included)

## CONDIST® TECHNOLOGY



Developed and patented by Contrinex, this innovative technology makes use of a high-performance oscillator for inductive sensors. Operating distances from **2.2 to 4 times** the standard values are possible thanks to excellent temperature and voltage stability. Devices of the 500 and 520 series work with such an oscillator (see also page 12).

## CONNECTORS



## PIN ASSIGNMENT SIZE S8:

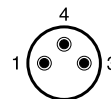

*N.O. and N.C.*

+U <sub>B</sub>	pin 1	brown
0V	pin 3	blue
output	pin 4	black

*Namur*

L+	pin 1	brown
L-	pin 4	blue

Analog output

+U <sub>B</sub>	pin 1	brown
0V	pin 3	blue
voltage output	pin 4	black

**PIN ASSIGNMENT SIZE S12:**

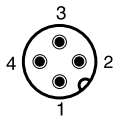

*N.O.*

+U <sub>B</sub>	pin 1	brown
0V	pin 3	blue
output	pin 4	black

*N.C.*

+U <sub>B</sub>	pin 1	brown
0V	pin 3	blue
output	pin 2	white

*2-wire DC / N.O.*

L-	pin 3	brown
L+	pin 4	blue

*2-wire DC / N.C.*

L-	pin 1	brown
L+	pin 2	blue

Analog output

+U <sub>B</sub>	pin 1	brown
0V	pin 3	blue
voltage output	pin 4	black
current output	pin 2	white

**PIN ASSIGNMENT SIZE 1/2":**

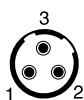

*2-wire AC/DC / N.O. and N.C.*

L1	pin 3	blue
L2	pin 2	brown
GND	pin 1	yellow/green



**PIN ASSIGNMENT SIZE S8 3 POLE:**

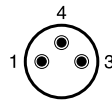

*N.O. and N.C.*

+U <sub>B</sub>	pin 1	brown
0V	pin 3	blue
output	pin 4	black

**PIN ASSIGNMENT SIZE S8 4 POLE:**

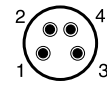

*N.O. and N.C.*

+U <sub>B</sub>	pin 1	brown
output 2	pin 2	white
0V	pin 3	blue
output 1	pin 4	black

*Teach*

+U <sub>B</sub>	pin 1	brown
output 2	pin 2	white
0V	pin 3	blue
output 1	pin 4	black

**PIN ASSIGNMENT SIZE S12 3 POLE:**

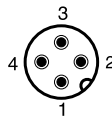

*N.O.*

+U <sub>B</sub>	pin 1	brown
0V	pin 3	blue
output	pin 4	black

**PIN ASSIGNMENT SIZE S12 4 POLE:**

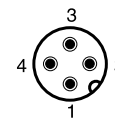

*N.O. and N.C.*

+U <sub>B</sub>	pin 1	brown
output 2	pin 2	white
0V	pin 3	blue
output 1	pin 4	black

*N.C.*

+U <sub>B</sub>	pin 1	brown
0V	pin 3	blue
output	pin 2	white

**PIN ASSIGNMENT SIZE S12 5 POLE:**

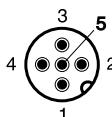

*N.O. and N.C.*

+U <sub>B</sub>	pin 1	brown
output 2	pin 2	white
0V	pin 3	blue
output 1	pin 4	black
test	pin 5	gray

## CORRECTION FACTORS



The specified operating distance **s** of inductive sensors refers to exactly defined measuring conditions (see **OPERATING DISTANCE**).

Other arrangements generally result in a reduction of the operating distance. The following data are to be considered as **guidelines** only; according to size and version, there can be wide variations. Exact values are given in the individual data sheets. These can be found on the Contrinex website ([www.contrinex.com](http://www.contrinex.com)), or ordered directly from our sales offices.

### SERIES 500 / 520\*

Material influence (indicative values):

Target material	Operating distance
Steel type FE 360	$s_n \times 1.00$
Aluminum	$s_n \times 0.36 / * 0.28$
Brass	$s_n \times 0.44 / * 0.37$
Copper	$s_n \times 0.32 / * 0.24$
Stainless steel (V2A)	$s_n \times 0.69$

Geometrical influence:

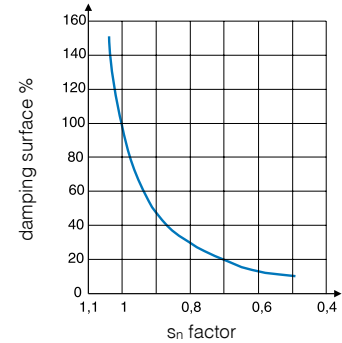

When using foils, an increase in the usable operating distance can be expected.

### SERIES 300 / 400 / 420 / 600 / 620

Material influence (indicative values):

Target material	Operating distance
Steel type FE 360	$s_n \times 1.00$
Aluminum	$s_n \times 0.55$
Brass	$s_n \times 0.64$
Copper	$s_n \times 0.51$
Stainless steel (V2A)	$s_n \times 0.85$

### SERIES 700

Material influence (indicative values):

Target material	Operating distance
Steel type FE 360	$s_n \times 1.0$
Aluminum	$s_n \times 1.0$
Brass	$s_n \times 1.3$
Copper	$s_n \times 0.8$
Stainless steel (1 mm thick)	$s_n \times 0.5$
Stainless steel (2 mm thick)	$s_n \times 0.9$

Geometrical influence:

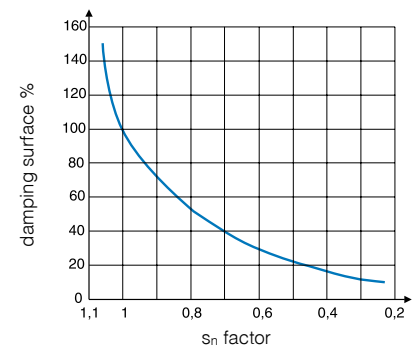

Geometrical influence:

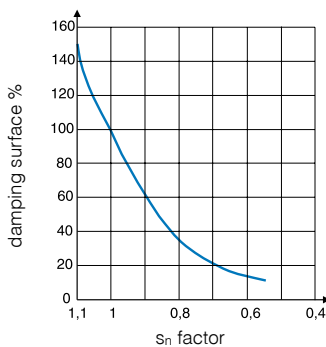

When using foils, an increase in the usable operating distance can be expected.

When using foils, a **decrease** in the usable operating distance can be expected.



Test card (Kodak paper, white)	100%
Paper, white	80%
PVC, gray	57%
Newspaper, printed	60%
Wood, lightly colored	73%
Cork	65%
Plastic, white	70%
Plastic, black	22%
Neoprene, black	20%
Automobile tires	15%
Aluminum sheet, untreated	200%
Aluminum sheet, black anodized	150%
Aluminum sheet, matt (brushed finish)	120%
Stainless steel, polished	230%

The specified sensing ranges of energetic diffuse sensors are achieved using standard matt white paper of the specified dimensions as the target surface. For other target surface materials, the correction factors given below apply (these are guideline values only).

# D

## DARK-ON



The “dark-ON” function means that the relevant output is switched (carrying current) when **no** light is reaching the receiver.

## DEGREES OF PROTECTION



The IP degrees of protection are defined in DIN 40050 / IEC 60529. The meaning of the **first numeral** is:

**6** The housing provides complete protection against contact with electrically conducting or moving parts, and full protection against dust penetration.

and the **second numeral**:

**4** Protection against water splashes: water splashed against the housing from any direction must have no harmful effect.

**Test conditions:** spraying with oscillating tube or spray nozzle; water pressure 1 bar; delivery rate 10 l/min ± 5%; duration 5 minutes.

**5** Protection against water jets: water projected by a nozzle from any direction under specified conditions must have no harmful effect.

**Test conditions:** nozzle with 6.3 mm diameter; delivery rate 12.5 l/min ± 5%; distance 3 m; duration 3 minutes.

**7** Protection against water when device is immersed in water under specified pressure and time conditions. Water must not penetrate in damaging quantities.

**Test conditions:** immersion depth in water 1 m; duration 30 minutes.

**8** Protection against water when device is immersed in water indefinitely under specified pressure conditions. Water must not penetrate in damaging quantities.

**Test conditions** used by Contrinex: immersion depth in water 5 m; duration ≥ 1 month.

**9K** Protection against water, which directed against the housing from any direction and under considerably increased pressure, must have no harmful effect.

**Test conditions:** sensor mounted on table turning at 5 ± 1 rpm; spraying with flat nozzle; delivery rate 14 - 16 l/min; distance 100 - 150 mm; angles 0°, 30°, 60° and 90°; temperature 80 ± 5 °C; pressure 8,000 - 10,000 kPa (80 - 100 bar); duration 30 sec per position.

Devices with degree of protection **IP 67** are thus **not intended for prolonged operation in water**, or in prolonged humid conditions. Tolerance to liquids other than water must be examined from case to case.

# E

## EMBEDDABLE MOUNTING



See **MOUNTING**.

## EMC



The EMC (**E**lectromagnetic **C**ompatibility) resistance of the devices satisfies the highest demands.



For inductive sensors, as a rule, the following requirements are met (for exact values, please refer to the data sheets):

### SERIES 300/400/420/500/520/700

IEC 61000-4-2	level 2
IEC 61000-4-3	level 3
IEC 61000-4-4	level 2
IEC 60947-5-2	5 kV

### SERIES 600 / 620

IEC 61000-4-2	level 2
IEC 61000-4-3	level 3
IEC 61000-4-4	level 3
IEC 60947-5-2	1 kV / 5 kV*

\*(M12 - C80)



For photoelectric sensors, see “technical data”.

All devices comply with the EU directive no. 2004/108/EC. In addition, they undergo severe field testing.

## EXCESS-GAIN INDICATION (SYSTEM RESERVE INDICATION)



The excess-gain indication circuit detects the excess radiation power which falls on the light incidence surface and is processed by the light receiver. The excess gain can decrease in time due to dirt, a change in the target’s reflection factor, and aging of the emitter diode, so that reliable operation can no longer be guaranteed. Some devices are therefore equipped with a second LED (green), which lights up when less than approximately 80% of

the available operating distance is used. In others, the yellow LED flashes when the available excess gain is insufficient. Models with an excess-gain output make the excess-gain signal available to the user for further processing. Thus, operating conditions which are no longer reliable can be recognized in time.

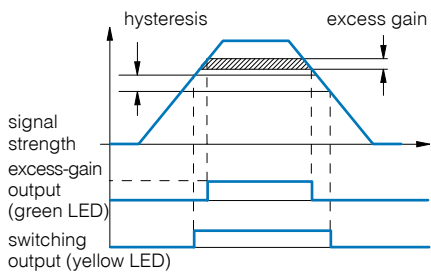

Fig. 23

# H

## HYSTERESIS



Hysteresis (differential travel) causes a defined switching behavior of the device (Fig. 24). The sensing range always refers to the switch-on point.

Distance hysteresis is only useful for the diffuse sensor model and its related fiber version.

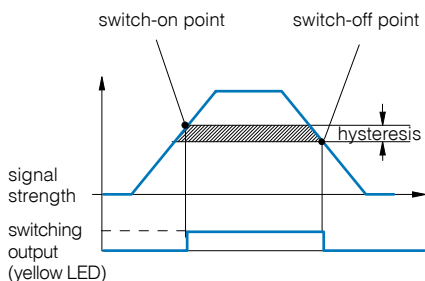

Fig. 24



Hysteresis (differential travel) causes a defined switching behavior of the device (Fig. 25). The operating distance always refers to the switch-on point. Namur devices and those with analog output have continuous transmission behavior, i.e. there is no hysteresis.

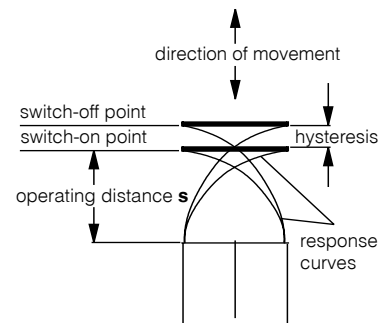

Fig. 25

## INDUCTION PROTECTION



When inductive loads are switched off, the output voltage, without a protective circuit, would increase to a high value, which could destroy the output transistor. Contrinex sensors therefore contain a **Zener diode** at the output to limit the switch-off voltage to a safe value (3-wire types). When connecting an inductive load with a current >100 mA and simultaneously a switching frequency >10 Hz, the mounting of a **roller diode** directly to the load is recommended (due to the leakage power in the built-in Zener diode).

## INSTALLATION



Photoelectric sensors can be easily and reliably installed in any position, using the mounting accessories supplied with most devices. The installation position should preferably protect the units against dirt and other contamination.



For inductive sensors, see **MOUNTING**.

## INSULATION VOLTAGE



The devices in this catalog are designed for an insulation voltage (between connecting leads and housing) of **500 VAC** (supply voltage up to 50 VAC / 75 VDC), or **1500 VAC** (supply voltage over 50 VAC / 75 VDC).

## IP 64 / IP 65 / IP 67 / IP 68 / IP 69K



Refer to **DEGREES OF PROTECTION**.

Inductive

Photoelectric

Optical fibers

Ultrasonic

Capacitive

Cables & connectors

Accessories

Glossary

Index

## IR LIGHT



IR is the abbreviation of “Infra-Red”. This refers to any electromagnetic radiation with a wavelength exceeding that of normal visible light, which is approx. 380 to 780 nm. Wavelengths of approx. 780 to 1500 nm are typically used. IR light cannot be used with synthetic fibers, due to high attenuation. Instead, visible red light is used. As the usual polarization filters cannot be used in the IR range, visible red light is also used for reflex sensors.



## LEAD LENGTHS



For the sensor, long leads mean:

- a capacitive load at the output (see **CAPACITANCE**)
- increased influence of interference signals

Even under favorable conditions, lead lengths should not exceed **300 m**.

## LEADS



The standard built-in leads are **not** suitable for **repeated bending stresses**. In such cases, high-flexibility PUR cables (special executions) or connectors with corresponding connecting cables (see page 268) must be used.

## LEAKAGE CURRENT



Leakage current is the current that flows through the output transistor and thereby through the load when the output is OFF (to be taken into account particularly where switches are connected in parallel).

## LED



Most of the inductive devices in this catalog are equipped with a built-in yellow light-emitting diode (LED). It indicates the switching state: **output activated = yellow LED on**. In case of a short-circuit, the LED remains off.



All photoelectric sensors have one or two **Light Emitting Diodes (LEDs)** built in. The yellow LED lights up when the output is switched (for switches with 2 outputs: the light-ON output). During a short-circuit or overload, the yellow LED does not operate. The green LED (if provided) lights up when enough system reserves (excess gain) for reliable operation are available, i.e. when an object is present in the reliable sensing area (diffuse sensors), or when enough light from the uninterrupted beam reaches the receiver (reflex and through-beam sensors). Switches without a green LED have the yellow LED flashing if the available system reserves are insufficient.

## LIGHT-ON



Light-ON means that the relevant output is switched (carrying current) when light is reaching the receiver.

## LOAD RESISTANCE



From the selected supply voltage  $U_B$  and the specified maximum output current of the sensor, the lowest permissible load resistance for trouble-free operation can be calculated.

Example: With a voltage of 24 V and a specified maximum permissible output current of 200 mA, the minimum load resistance is 120 ohm; at 15 V, it is 75 ohm.



## MAGNETIC FIELDS



Permanent and low-frequency alternating magnetic fields do not normally influence the operation of sensors.



**Strong fields**, on the other hand, can saturate the ferrite core of inductive sensors, thereby increasing the operating distance, or even provoking through-connection. However, no lasting damage is caused. **High-frequency fields** of several kHz (700 series), or several hundred kHz (other series), may seriously interfere with the switch functioning, since the oscillator frequency of the devices lies in this range. If difficulties with interfering magnetic fields are encountered, shielding is recommended.

## MODULATED LIGHT



The photoelectric sensors listed in this catalog operate with modulated light, i.e. the light emitter is switched on only for a short period and remains switched off for much longer (ratio approx. 1:25). In diffuse and reflex sensors, the receiver is only active during the light pulse, and is disabled during the pulse gap. Operation with modulated light provides the following advantages:

- The devices are largely insensitive to ambient light
- Longer sensing ranges are possible
- Heat generation is reduced, which prolongs the operating life of the emitting diodes

## MODULATION FREQUENCY



The photoelectric devices in this catalog are operated with modulated light, which makes them largely insensitive to ambient light. The modulation frequency  $f_{cy}$  is in the range of several kHz.

If a device is operated in the proximity of another device with the same modulation frequency, interference can occur.

If the problem cannot be solved by suitable alignment of the units or by shielding, sensors with different modulation frequencies can be supplied as an option.

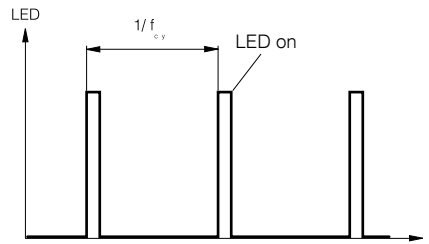

Fig. 26

## MOUNTING



For photoelectric sensors, see **INSTALLATION**.



## EMBEDDABLE SENSORS

Embeddable sensors may be flush mounted in all metals. For trouble-free operation, a free zone according to Fig. 27 should be observed.

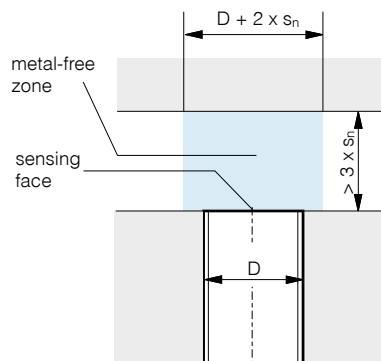

Fig. 27

## QUASI-EMBEDDABLE SENSORS

When installing quasi-embeddable series 500 and 520 sensors in conductive materials (metals), the devices must **protrude** by a distance **X**, according to Fig. 28. Further, a free zone of  $3 \times s_n$  must be observed. Flush mounting in non-conducting materials is permitted.

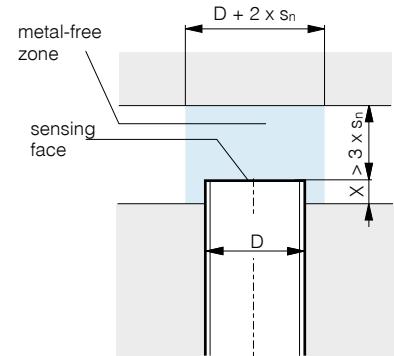

Fig. 28

*Mounting in steel and in non-ferrous metals:*

Housing size D	X (mm)
Ø 6.5	1
C8	1
M12	2
M18	4
M30	6

*Mounting in stainless steel:*

Housing size D	X (mm)
Ø 6.5	0.0
C8	0.0
M12	1.0
M18	1.5
M30	2.0

## NON-EMBEDDABLE SENSORS

When mounting non-embeddable sensors in conducting materials (metals), minimum distances to the conducting material must be maintained according to Fig. 29. Flush mounting in non-conducting materials is permitted.

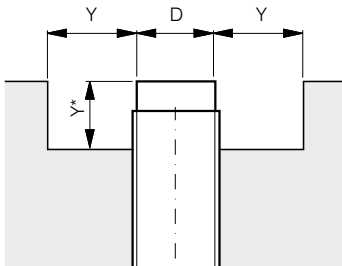

Fig. 29

Housing size D	Y (mm)
M8	8
M12	12
M18	22
M30	40
C44	60 / *40
C40	70 / *40
C60	60 / *40
C80	110 / *40

## N

N.C.



The output is closed when the switch is not activated. It is open when the switch is activated.

N.O.



The output is open when the switch is not activated. It is closed when the switch is activated.

## NO-LOAD SUPPLY CURRENT



No-load supply current is understood as the inherent consumption of the sensor for operating the LED, amplifier, etc., in the non-activated state. It does not include the current flowing through the load.

## NON-EMBEDDABLE MOUNTING



See **MOUNTING**.

## NPN CONFIGURATION



The output device contains an NPN transistor, which switches the load towards zero voltage. The load is connected between the output terminal and the positive supply voltage  $+U_B$  (Fig. 30).

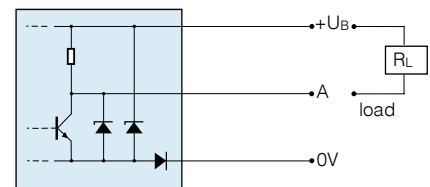

Fig. 30

## O

## OIL RESISTANCE



Long-term contact with any oils may affect plastics and weaken their resistance. However, inductive series 700 sensors, as well as the sealed (series E) and high-pressure-resistant (series P) types can be used in **oily environments** without restriction. For all other types, this is not necessarily the case.

Thus, please observe the following:

### Lubricating oils:

Generally cause no problems. Use versions with oil-resistant PUR cable (special executions).

### Hydraulic oils, cutting oils:

These attack most plastics. In particular, PVC cables discolor and become brittle. Measures:

- Wherever possible, avoid contact with these liquids, particularly at the sensing face.
- Use versions with oil-resistant PUR cable.



For photoelectric sensors, housing, optical unit, and cable should be considered separately:

## Housing

The PBTP / polybutyleneterephthalate (Crastin) used for the housing is highly resistant to all conventional types of oil, in particular, to cutting and hydraulic oils, as well as drilling emulsions.

## Optics

The windows are generally of glass (with the exception of series 5050), and are therefore not affected. However, oil on the light in- and outputs changes their optical properties. The effects should be examined from case to case.

## Cable

The PVC cable used as standard is not resistant to most types of oil, and becomes brittle in long-term use. The optional PUR cable should therefore be used in oily environments.

## OPERATING DISTANCE



The operating distance of inductive sensors is the distance at which a target approaching the sensing face triggers a signal change. The operating distance is measured according to IEC 60947-5-2 / EN 60947-5-2, using a **standard square target** moving **axially** (Fig. 31). This target is made of steel, e.g. type FE 360 in accordance with ISO 630, with a smooth surface, square shape, and thickness of 1 mm (Fig. 32). The sides equal the **diameter** of the inscribed circle of the sensing face or **three times the rated operating distance  $s_n$**  of the sensor, whichever is the greater.

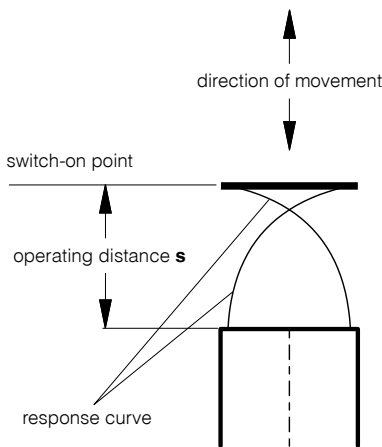

Fig. 31

### Rated operating distance $s_n$

This is the operating distance for which the sensor is designed. It can be found under "technical data".

### Effective operating distance $s_r$

The measured operating distance for a given switch according to IEC 60947-5-2 / EN 60947-5-2.

$$0.9 s_n \leq s_r \leq 1.1 s_n$$

This means that the manufacturing tolerance must not exceed  $\pm 10\%$ .

### Usable operating distance $s_u$

This distance takes into account expected additional deviations caused by temperature and supply voltage fluctuations within the specified range.

$$0.9 s_r \leq s_u \leq 1.1 s_r$$

The temperature and supply voltage ranges can be found under "technical data".

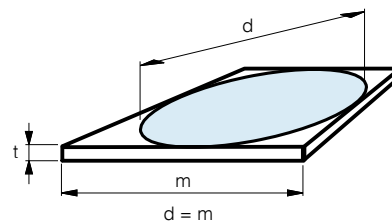

Fig. 32

## Assured operating distance $s_a$

$$0 \leq s_a \leq 0.81 s_n$$

This operating distance is guaranteed by the manufacturer for all specified operating conditions. It is the **basis for a safe design**.



See **SENSING RANGE**.

## OPTICAL FIBERS



An optical fiber can consist of a bundle of glass fibers, or one or more synthetic fibers. It is used to conduct light from one place to another, even around bends and curves. This is possible thanks to the phenomenon of total reflection. Total reflection always occurs when light coming from a material with a higher refractive index falls on an interface with a medium having a lower refractive index, in such a way that the critical angle required for total reflection is never reached.

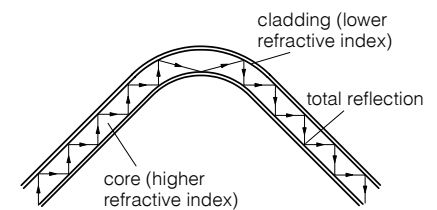

Fig. 33

The fibers consist of a core (with a higher refractive index) and a cladding (with a lower refractive index). Due to total reflection, the light is reflected backwards and forwards in the core, and can thus go round bends and curves.

## OUTPUT CURRENT



The devices are designed for a given maximum output current. If this current is exceeded, even for only a short time, the **overload protection** trips. Incandescent lamps, capacitors, and other heavily capacitive loads (e.g. long leads) have a similar effect to overload (see also **CAPACITANCE**).

## OUTPUT RESISTANCE



In order that the output voltage, even without external load, follows the switching state, Contrinex sensors contain a built-in output resistance (pull-up resistor). For operation at high switching frequencies, an additional external load resistor must be added (to reduce the electrical time constant).

## OVERVOLTAGE PROTECTION



For maximum operating reliability and ease of use, Contrinex sensors feature a built-in protection circuit against very short, non-periodic supply voltage peaks, which complies with the requirements of IEC 60947-5-2.

# P

## PARALLEL CONNECTION



Connecting sensors in parallel, in order to perform logic functions, is possible without any problem (Figs. 34 and 35).

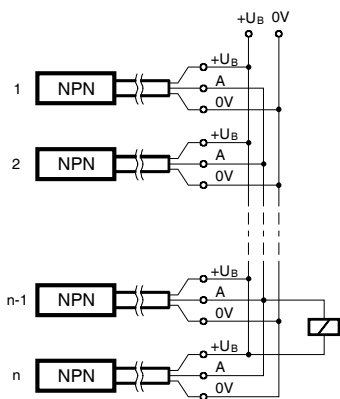

Fig. 34

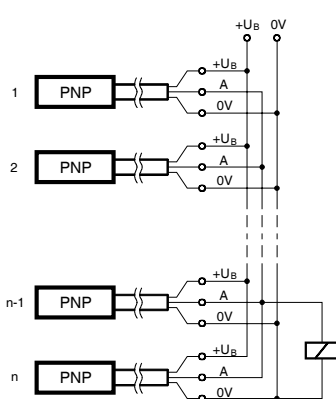

Fig. 35

Please note:

- The no-load supply current increases.
- Leakage currents add up, so that, even when closed, an inadmissible voltage drop can occur at the output.

## PNP CONFIGURATION



The output device contains a PNP transistor, which switches the load towards the positive supply voltage  $+U_B$ . The load is connected between the output terminal and the negative supply voltage  $0V$  (Fig. 36).

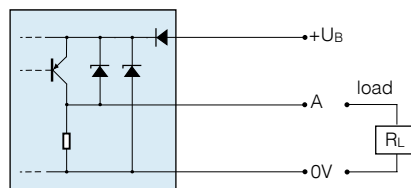

Fig. 36

## POLARITY REVERSAL PROTECTION



Virtually all sensors in this catalog are protected against **any polarity reversal** at all terminals.

## POLARIZATION FILTER

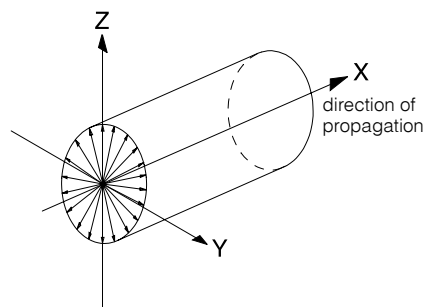

Fig. 37

Natural light (including the light from the emitter diodes) is not polarized (Fig. 37). When light has passed through a polarizing filter however, only that part of the original light which oscillates in the filter polarization direction is still present (Fig. 38). Polarization is retained after reflection by mirrored surfaces, only the direction of polarization may be altered. Diffuse reflection, on the other hand, destroys polarization. This difference can be used to suppress the disruptive effects caused by mirrored surfaces, by means of selection and configuration of suitable filters.

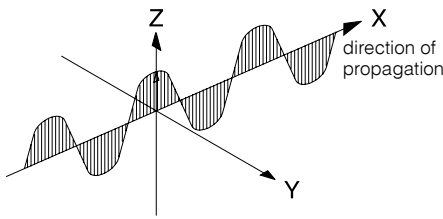

Fig. 38

## POWER-ON RESET



When switched on, the sensor output is activated for a short time due to physical reasons, even without the presence of a target in front of the sensing face. Sensors with power-on reset therefore include an additional circuit that closes the output for a short time during the switching-on phase, so suppressing an error signal (this function is also known as “switch-on pulse suppression”).

## POWER SUPPLY UNITS



Circuit recommendations for suitable power supply units are shown in Figs. 39 and 40.

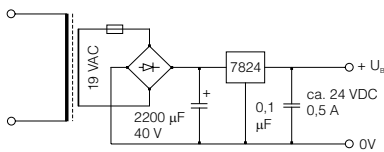

Fig. 39

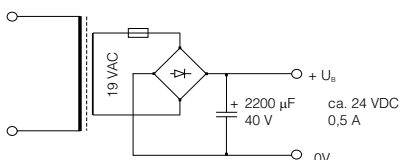

Fig. 40

The Contrinex accessory program also includes a suitable power supply unit (page 274).

Please observe:

- Unsuitable power supply units are the most frequent reason for sensor problems!

- A transformer and rectifier are not sufficient; at least a smoothing capacitor is essential (due to the ripple content).
- Transformers with a 24 V output, rear-position rectifier and smoothing capacitor deliver a no-load voltage of well above 30 V. Consequently, devices with a maximum supply voltage of 30 V can be damaged.

# R

## REFLECTORS



By means of built-in polarization filters, polarized reflex sensors are designed so that they respond only to the light reflected from special reflectors. These operate according to the principle of the 3-way mirror (Fig. 41). The choice of the correct reflector for a specific application is determined by the required operating distance and installation possibilities. The reflector must be installed perpendicularly to the optical axis (tolerance  $\pm 15^\circ$ ).

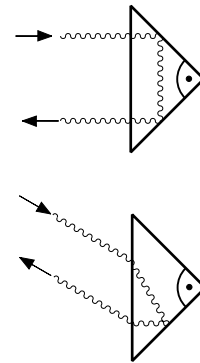

Fig. 41

## REPEAT ACCURACY



Repeat accuracy (according to IEC 60947-5-2 / EN 60947-5-2) is understood to be the repeat accuracy of the effective operating distance  $s_r$  over an 8-hour period at an ambient temperature of  $23 \pm 5^\circ\text{C}$  and with a specified supply voltage  $U_B$ . The specified repeat accuracy refers to this definition. Successive measurements made immediately one after the other generally lead to much better repeat accuracy.

## RESPONSE DIAGRAM



The specified values for the operating distance refer to an **axial** approach of the target. For staggered or lateral movements, type-specific response curves are valid. Two typical examples are shown below (Fig. 42 and Fig. 43):

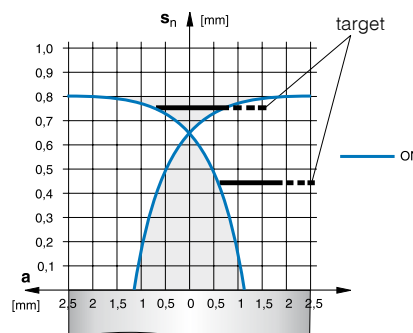

Fig. 42 DW-AD-403-M5

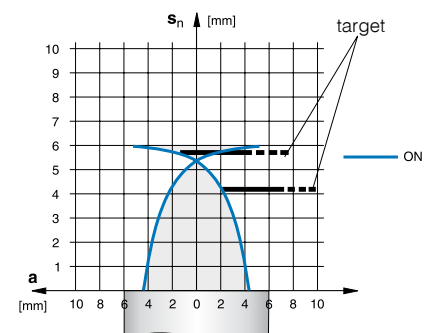

Fig. 43 DW-AD-503-M12

Depending on series, size, and mounting type (embeddable or non-embeddable), the response diagrams differ. Response diagrams for switch types not shown here are readily available from the corresponding individual data sheets. These can be found on the Contrinex website ([www.contrinex.com](http://www.contrinex.com)), or ordered from our sales offices.

## RIPPLE CONTENT



Too much ripple content causes undefined switching behavior. To remedy this, use a larger smoothing capacitor, or a stabilized power supply unit. The specified maximum supply voltage  $U_B$  must not be exceeded, not even during  $U_{SS}$  peaks.

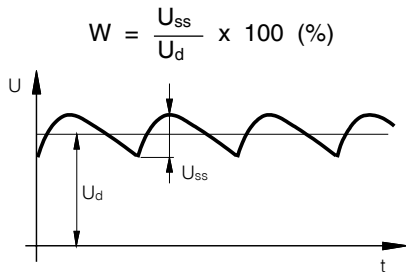

Fig. 44

## S

### SAFETY



The devices in this catalog have not been designed for safety-relevant use. In cases where the safety of people is dependent on their functioning, it is the user's responsibility to ensure that the relevant standards, in particular ISO 13849-1, and regulations are complied with. Contrinex assumes no liability for personal injury.

### SENSING RANGE



The specified sensing range of photoelectric sensors is the maximum usable distance between the device and the standard target (diffuse sensors); between the device and the reference reflector (reflex sensors), and between the emitter and the receiver (through-beam sensors). The potentiometer must be set for maximum sensitivity, or for diffuse sensors

with background suppression, for maximum sensing range. Moreover, the specified reflector (reflex sensors) or standard target (diffuse sensors) must be used.

## SERIES CONNECTION



The connection of sensors in series in order to achieve logic functions is possible, but not recommended. The same effect can be achieved by the **parallel connection** of sensors with **N.C. function** (instead of the series connection of models with N.O. function), or vice versa. However, please note that, as a result, the output signal is inverted.

## SHOCK RESISTANCE



The sensors in this catalog are tested for resistance to a shock of 30 g (30 times gravitational acceleration) for a period of 11 ms, according to IEC 60068-2-27.

## SHORT-CIRCUIT PROTECTION



The devices in this catalog feature built-in pulse protection against short-circuits and overloads, which alternately closes and opens the output when the maximum output current is exceeded, until the short-circuit is eliminated. Short-circuits between the output and the supply voltage terminals do not damage the sensor, and are allowed in permanence. The same applies to overloads. During short-circuits, the LEDs do not function.

## SPHERICAL OPTICS



Spherical lenses are special cases of double convex lenses. They feature a short focal length and a good light incidence area. They are known for their use in the optical coupling of optical fibers, where the mentioned characteristics can be used to their advantage. New, however, is the use of such optics in coupling the light produced or received by a semiconductor chip (LED or photodiode) into (LED), or out of (photodiode) an optical space. Fig. 45 shows such a design, as it is used in the LT#-1040/1050-30#-50# switches (see pages 147 and 148).

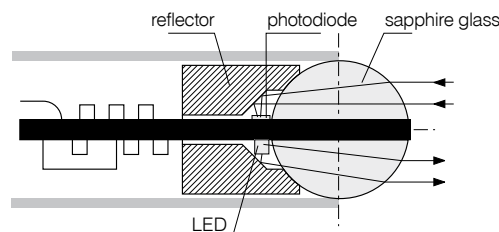

Fig. 45

For the diffuse sensor, the sphere is cut in two, in order to separate the reception from the emission channel. The emitter and receiver semiconductor chips are mounted as closely as possible to the surface of the sphere. As can be seen in Fig. 45, the chips are positioned slightly off the optical axis. In optics, this is usually a disadvantage, but not in this case: The emitted beam and the sensing range of the receiver section "squint" somewhat, i.e. they cross at a specific distance from the device. Consequently, the sensing range is relatively short, but the detection zone is virtu-

ally cylindrical. This is unusual for photoelectric sensors, and allows for interesting new application possibilities, such as, for instance, the detection of targets through narrow holes or gaps.

## STANDARDS



The sensors in this catalog comply, either completely or to a great extent, with the following standards:

- IEC 60947-5-1, **IEC 60947-5-2**, EN 60947-5-1, **EN 60947-5-2**
- IEC 61000-4-1, 61000-4-2, 61000-4-3, 61000-4-4, DIN EN 55011, DIN EN 55081-2, DIN EN 50140
- IEC 60529 / DIN 40050
- IEC 60947-1 / EN 60947-1 / DIN VDE 0660, part 100, part 100 A3, part 200, part 208
- DIN EN 50008, 50010, 50025, 50026, 50032, 50036, 50037, 50038, 50040, 50044

## SUPPLY VOLTAGE $U_B$



The specified maximum supply voltages must **not be exceeded**. For maximum operating reliability and ease of use, Contrinex sensors contain a built-in protection circuit against very short, non-periodic, supply voltage peaks, which complies with the requirements of IEC 60947-5-2. Operating voltages below the lower specified limit, even for short periods, do not damage the switches, but impede their operation.

## SWITCHING FREQUENCY



The maximum switching frequency of inductive sensors indicates the highest permissible number of pulses per second for a constant pulse/pause ratio of 1 : 2 at **half the rated operating distance  $s_n$** . Measurement is according to IEC 60947-5-2 / EN 60947-5-2 (Fig. 46).

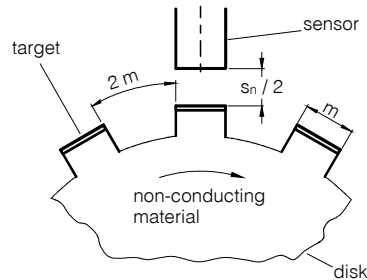

Fig. 46



The maximum switching frequency of photoelectric sensors is determined with the aid of a rotating sector disk. Designed so that a light to dark ratio of 1:1 results, it is placed in the path of the beam. The maximum switching frequency is reached just at the point where no output signal pulses are lost.

## T

### TEACH-IN



In the majority of applications, each sensor has to be adjusted according to the specific conditions. The adjustment usually concerns the sensing range, and is effected by turning a potentiometer screw. However, an alternative is offered by the teach-in process. Before starting the distance setting by teach-in, the target and/or the eventual background are positioned. Then, by pressing a button on the device, or remotely by means of an electrical signal, the teach process is triggered, in which a built-in microcontroller, starting from the minimum value, increases the switching threshold until the output switches. This switching threshold is digitally stored by the microcontroller in a non-volatile memory (EEPROM), and determines the sensor's subsequent switching behavior. The microcontroller then adapts the switching threshold thus found to the respective application. Depending on the device, or the selected mode, the teach function is applied to the target, the background, or first to the one, and then the other. With newer devices, the teach process can also be remotely triggered by means of a PLC via a control lead, or via IO-Link.

### TEMPERATURE DRIFT



The set sensing ranges are subject to slight temperature influences. Due to built-in temperature compensation, this effect is much less important for devices of the 4040 series (approx. 0.1 % / °C) than for the other switches (approx. 0.3 %/°C). The sensing range, as a function of ambient temperature, follows approximately the curves shown in Fig. 47.

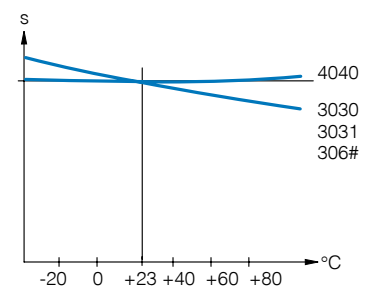

Fig. 47



The specified operating distances refer to a nominal ambient temperature of 23°C. The operating distance, as a function of ambient temperature, follows approximately the curve shown in Fig. 48.

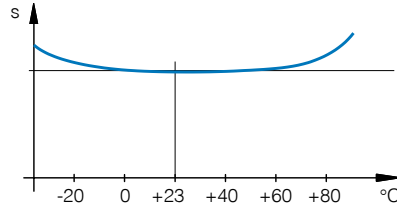

Fig. 48

The temperature of the target itself has practically no influence on the operating distance. Within the permitted temperature range of, as a rule, -25°C to +70°C, the operating distance varies by a maximum of ± 10% compared to its value at 23°C.

### TIME DELAY BEFORE AVAILABILITY



The time delay before availability is the maximum time the sensor requires for **operating readiness** after the supply voltage has been switched on.

### V

### TEST INPUT



The emitters of through-beam sensors, as well as a number of series 6080 types, are provided with a test input. Light emission can be switched on and off by means of this input, which, together with the corresponding evaluation of the receiver reaction, permits very efficient sensor monitoring.

### VIBRATION RESISTANCE



The sensors in this catalog are tested for resistance to vibrations of 1 mm amplitude at 55 Hz, according to IEC 60068-2-6.

### TIGHTENING TORQUE



Over-tightening of the nuts can mechanically damage cylindrical sensors. The specified maximum permissible tightening torques must therefore not be exceeded.

### VOLTAGE DROP



In the switched-through condition, a (current dependent) voltage drop develops across the output transistor; the output voltage, therefore, does not entirely reach the corresponding supply voltage (to be particularly taken into account with series connection and electronic inputs).



#### SERIES 300, 400, 420, 500\*, 520\*, 600, 620

Housing size D	M (Nm)
M4	0.8
M5	1.5
C5	0.2
M8	10 / *4
C8	1
M12	10
M18	25
M30	70



#### SERIES 700

Housing size D	M (Nm)
M8	6
M12	20
M18	50
M30	150



#### SERIES 1040 / 50, 1120, 1180, 1180W

Housing size D	M (Nm)
M5	1.5
M12	10
M18 / M18W	20

### W

### WIRE-BREAK PROTECTION



All sensors in this catalog are equipped with wire-break protection. If a voltage supply lead breaks, the output is disabled, thus avoiding an error signal.



Sensor cables must not be laid in parallel in the same cable runs as cables connected to **inductive loads** (i.e. protection solenoids, magnetic rectifiers, motors, etc.), or which conduct currents from **electronic motor drives**. Leads should be kept as short as possible; however, with suitable wiring (low coupling capacitance, small interference voltages), they can be up to 300 m long.

To reduce electromagnetic interference, apply the following measures:

- Maintain the distance to interfering cables > 100 mm
- Use shields
- Install inductances (contactors, magnetic rectifiers, relays) with RC networks or varistors

