

Standard Industrial Types Absolute



Absolute shaft encoders, also known as shaft-angle encoders, are by no means used only to detect angular positions. They are also suitable for linear movements that can be converted into rotary movements by a toothed belt, drive pinion, or wire winch.

The special feature of absolute shaft encoders is that they assign a unique, digitally encoded signal to each individual measured increment. The method of transducing prevents erroneous readings, whether by a power failure, or by a transient malfunction. After the encoder is switched on again, or power is restored, the position can be read out. It is not necessary to move to a reference position, as it is for shaft encoders of the incremental type.

Examples of application for absolute encoders

- overhead support robots
- ventilation flaps
- spinning machines
- conveyor belts
- cam controllers
- injection moulding machines
- packaging machinery
- extruders
- folding machines
- printing machines
- high lift storage systems
- stamping machines

Absolute

BiSS / SSI



- Overall length: 36 mm
- For equipment engineering and industry
- Up to 17 Bit Resolution Singleturn + 12 Bit Multiturn
- Solid shaft 6 mm (Hollow shaft version: AD 36)
- +100°C operating temperature
- 10,000 rpm (continuous)
- Optical encoder with a true geared multiturn
- BiSS or SSI interface
- Option Sinewave 1 Vpp
- Bandwidth 500 kHz



APPLICATIONS

The AC 36 is an absolute optical encoder with a true geared multiturn, optical sensing technology and 36 mm diameter. Equipped with a solid-shaft the AC 36 is mechanical compatible with all common inkremental encoders. The compact design allows to replace the adequate incremental encoders directly. As a result the technical facilities of absolute encoders can be used for the first time in equipment engineering and also in medical engineering. The mechanical design consists of two ball bearings supported mechanical shaft assembly. The AC 36 complements the **ACURO® -industry** series with small frame sizes and the same performance as 58 mm versions.

BiSS-Interface

Unique within his class the AC 36 provides fully digital position data up to 17 Bit (singleturn) and 12 Bit (multi-turn) over the bidirectional synchronous interface with a variable clock rate up to 10 MHz. This corresponds a singleturn resolution of more than 130 000 mesured steps. Backward compatibility is realized through the SSI interface together with 2048 sine-cosine periods per revolution.

Integrated diagnostic system

The AC 36 is based on latest OptoAsic technology with an advanced diagnostic concept. A continous plausibility check controls the internal signal processing for each increment. A code check guarantees that the encoder signal represents bit by bit the mesured rotation. Also the operating temperature of the encoder can be measured, read out and monitored over warn and alarm bits with 8 bit resolution (1°C). Monitoring and controlling of the operating temperature ensures a maximum lifetime of the LED. Eventual failures are indicated early over warn bits.

TECHNICAL DATA
mechanical

Housing diameter	37.5 mm
Shaft diameter	6 mm (Solid shaft)
Flange (Mounting of housing)	Pilot flange
Protection class shaft input (EN 60529)	IP64
Protection class housing (EN 60529)	IP64
Max. speed	max. 10 000 rpm (continuous), max. 12 000 rpm (short term)
Torque	0.01 Nm
Moment of inertia	ca. 2.5×10^{-6} kgm ²
Vibration resistance (DIN EN 60068-2-6)	100 m/s ² (10 ... 2000 Hz)

Absolute

BiSS / SSI

TECHNICAL DATA
mechanical (continued)

Shock resistance (DIN EN 60068-2-27)	1000 m/s ² (6 ms)
Operating temperature	-25 °C ... +100 °C
Storage temperature	-15 °C ... +85 °C
Weight	approx. 80 g (ST) / 130 g (MT)
Connection	Cable, axial or radial

TECHNICAL DATA
electrical

Supply voltage	-5%/ 10% DC 5 V DC 7-30 V
Max. current w/o load	50 mA (ST), 100 mA (MT)
Resolution singleturn	12 -17 Bit
Resolution multiturn	12 Bit
Output code	Gray, Binary
Drives	Clock and Data / RS422
Incremental signals optional	Sinus-Cosinus 1 Vpp
Number of pulses	2048
3dB limiting frequency	500 kHz
Alarm output	Alarm bit (SSI Option), warning and alarm bit (BiSS)

ELECTRICAL CONNECTIONS
Cable

Signal	Colour cable
5 / 7-30 V (U _B)	white
0 V (U _N)	brown
Clock	yellow
$\overline{\text{Clock}}$	green
Data	pink
$\overline{\text{Data}}$	grey
A	white/green ¹
\overline{A}	brown/green ¹
B	red/blue ¹
\overline{B}	grey/pink ¹
5 V Sensor	violet ¹
0 V Sensor	black ¹

¹ only with "SC"

DIMENSIONED DRAWINGS

Connection axial

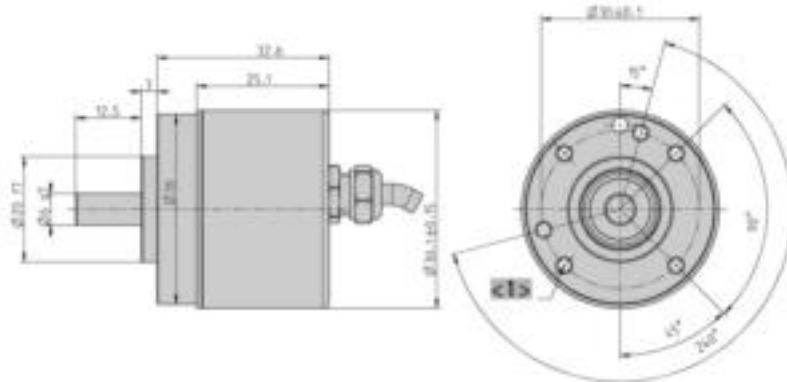

<1> M3 (depth 6)

Dimensions in mm

Connection radial

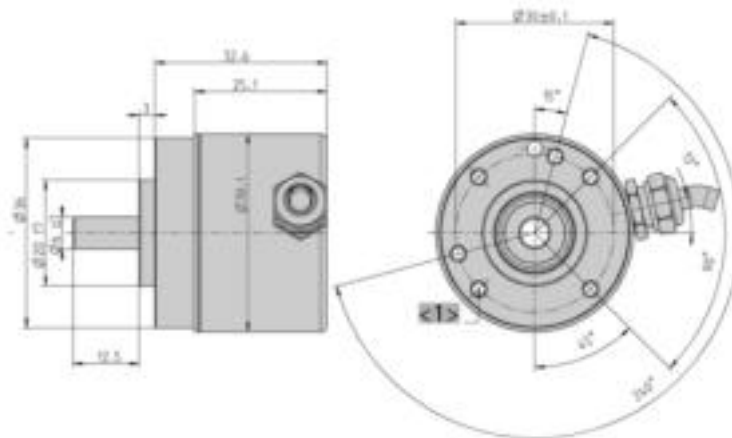

<1> M3 (depth 6)

Dimensions in mm

ORDERING INFORMATION

Type	Resolution	Supply voltage	Flange, Protection, Shaft	Interface	Connection
<input type="checkbox"/>	<input type="text"/>	<input type="checkbox"/>	<input type="checkbox"/>	<input type="checkbox"/>	<input type="checkbox"/>
AC36	0012 12 Bit ST 0013 13 Bit ST 0014 14 Bit ST 0017 17 Bit ST 1213 12 Bit MT + 13 Bit ST 1217 12 Bit MT + 17 Bit ST (BiSS)	A DC 5 V E DC 7 - 30 V	R.41 Pilot, IP64, 6 mm	BI BiSS SB SSI binary SG SSI Gray SC SSI Gray (+SinCos 1Vpp)	A Cable, axial B Cable, radial

Absolute**BiSS / SSI****ORDERING INFORMATION**
Selection of cable length

Versions with cable outlet (connection A, B, E or F) are available with various lengths of cable. To order your desired cable length, please add the respective code to the end of your ordering code. Further cable lengths on request.

Code	Cable length
without code	1.5 m
-D0	3 m
-F0	5 m
-K0	10 m
-P0	15 m
-U0	20 m
-V0	25 m

ACCESSORIES

see chapter "Accessories", starting page 322

Absolute Shaft Encoders ACURO industry

Overview Functions and Versions AC 58

	SSI	BiSS	Parallel ST	Parallel MT	SSI para.	Profibus	DeviceNet	Interbus	CAN	CANopen	SUCOnet
Electrical											
Supply DC 5 V	•	•	(Option)	(Option)							
Supply DC 10-30 V	•	•	•	•	•	•	•	•	•	•	•
Preset key with LED (not IP67)	•	•	only LED	•	•						
Diagnostics											
- LED indication	•	•		•	•	•	•	•	•	•	
- Warning		•				•					
- Alarm bit	(Option)	•				•	•	•	•	•	
- Alarm output	(Option)	(Option)	•	•							
- Temperature measurement	(Option)	•									
Connection for "tico"						•	•		•	•	
Parameterization (PC, with Acuro Soft)	•	•									
Parameterization (Bus)						•	•	•		•	•
Inputs											
- Latch			•	•							
- Direction	•	•	•	•	•						
- 2 lines for present input					•						
- Tristate			•	•							
Special Functions											
- Speed						•			•	•	
- Acceleration						•			•	•	
- On time						•				•	
- Round axis										•	
- Limit values					•					•	
Optional 1 Vpp	•	•									
Connections											
Bus cover, 3 cable screw						•		•	•	•	
Bus cover, 2 cable screw+M12 for "tico"						•	•		•	•	
Bus cover, 2 cable screw							•				
Bus cover, 2 Conin 9-pole								•	•	•	
Bus cover, 2 Conin 12-pole						•					
Bus cover, 3 M12 4-pole						•					
Bus cover, 1 M12 5-pole							•				
Cable axial / radial	•	•	•	•	•			•	•	•	•
Cable ax /rad 0.1 m+37-pole Sub-D				•							
Conin 12-pole ax/rad CW/CCW	•	•			•	•			•	•	
Conin 17-pole ax/rad CW/CCW			•								
M12 8-pole ax/rad	•	•									
Mechanical											
Synchro fl., shaft 6x10 mm, IP64 or IP67	•	•	•	•	•	•	•	•	•	•	•
Clamping fl., shaft 10x19.5 mm, IP64 or IP67	•	•	•	•	•	•	•	•	•	•	•
Clamping fl., shaft 9.52x19.5 mm, IP64 or IP67	•	•	•	•	•	•	•	•	•	•	•
Hubshaft with tether 10 mm, IP64	•	•	•	•	•	•	•	•	•	•	•
Hubshaft with tether 12 mm, IP64	•	•	•	•	•	•	•	•	•	•	•
Hubshaft with tether 12,7 mm, IP64	•	•	•	•	•	•	•	•	•	•	•
Square flange, 63.5 mm, shaft 9.52x19.5 mm, IP64 or IP67	•	•	•	•	•	•	•	•	•	•	•
Square flange, 63.5 mm, shaft 10 x 19.5 mm, IP64 or IP67	•	•	•	•	•	•	•	•	•	•	•

Absolute

BiSS / SSI



Clamping flange

- Compact design: 50 mm length for single or multiturn
- Aids for start up and operation: diagnostic LED, preset key with optical response, status information
- Use of sine/ cosine signals for fast control task possible
- Control input: Direction
- Resolution up to 29 Bit

TECHNICAL DATA
mechanical

Housing diameter	58 mm
Shaft diameter	6 mm / 10 mm (Solid shaft) 10 mm / 12 mm (Hub shaft)
Flange (Mounting of housing)	Synchro flange, Clamping flange, Tether, Square flange
Protection class shaft input (EN 60529)	IP64 or IP67
Protection class housing (EN 60529)	IP64 or IP67
Shaft load axial / radial	40 N / 60 N
Axial endplay of mounting shaft (hubshaft)	± 1.5 mm
Radial runout of mating shaft (hubshaft)	± 0.2 mm
Max. speed	max. 10 000 rpm (continuous), max. 12 000 rpm (short term)
Torque	0.01 Ncm
Moment of inertia	ca. 3.8 x 10 ⁻⁶ kgm ²
Vibration resistance (DIN EN 60068-2-6)	100 m/s ² (10 ... 2000 Hz)
Shock resistance (DIN EN 60068-2-27)	1000 m/s ² (6 ms)
Operating temperature	-40 °C ... +100 °C
Storage temperature ¹	-25 °C ... +85 °C
Weight	approx. 260 g (ST) / 310 g (MT)
Connection	Cable, axial or radial M23 connector (Conin), 12 pole, axial or radial M12-connector, 8 pole, axial or radial

¹ due to packaging

TECHNICAL DATA
electrical

Supply voltage	± 10% DC 5 V or DC 10 - 30 V
Max. current w/o load	50 mA (ST), 100 mA (MT)
Resolution singleturn	10 - 17 Bit Gray Excess: 360, 720 increments
Resolution multiturn	12 Bit
Output code	Binary, Gray
Drives	Clock and Data / RS422
Linearity	± ½ LSB (± 1 LSB for resolution > 13 Bit)

Absolute

BiSS / SSI

TECHNICAL DATA electrical (continued)

Incremental signals optional	Sinus-Cosinus 1 Vpp
Number of pulses	2048
3dB limiting frequency	500 kHz
Absolute accuracy	±35"
Repeatability	±7"
Parametrization	Code type, Direction, Warning, Alarm
Control inputs	$\overline{\text{Direction}}$
Reset key	Disable via parameterization
Alarm output	Alarm bit (SSI Option), warning and alarm bit (BiSS)
Status LED	Green = ok, red = alarm

RECOMMENDED DATA TRANSFER RATE bei SSI

The max. data transfer rate depends on the cable length. For Clock / $\overline{\text{Clock}}$ and Data / $\overline{\text{Data}}$ please use twisted pairs. Use shielded cable.

Cable length	Frequency
< 50 m	< 400 kHz
< 100 m	< 300 kHz
< 200 m	< 200 kHz
< 400 m	< 100 kHz

DATA FORMAT Singleturn

Resolution	Data Bits											
	T1 ... T9	T10	T11	T12	T13	T14	T15	T16	T17	T18	T19	
9 Bit ¹	S8 ... S0	0	0	0	0	0	W ²					
10 Bit ¹	S9 ... S1	S0	0	0	0	0	W ²					
11 Bit ¹	S10 ... S2	S1	S0	0	0	0	W ²					
12 Bit ¹	S11 ... S3	S2	S1	S0	0	0	W ²					
13 Bit ¹	S12 ... S4	S3	S2	S1	S0	0	W ²					
14 Bit ¹	S13 ... S5	S4	S3	S2	S1	S0	0	W ²				
15 Bit ¹	S14 ... S6	S5	S4	S3	S2	S1	S0	0	W ²			
16 Bit ¹	S15 ... S7	S6	S5	S4	S3	S2	S1	S0	0	W ²		
17 Bit ¹	S16 ... S8	S7	S6	S5	S4	S3	S2	S1	S0	0	W ²	

Examples for data format 9 Bit and 13 Bit with the optional bits alarm und parity

Resolution	Data Bits											
	T1 ... T9	T10	T11	T12	T13	T14	T15	T16	T17	T18	T19	
9 Bit + P ³	S8 ... S0	0	0	0	P	0	W ²					
9 Bit + A ⁴	S8 ... S0	0	0	0	A	0	W ²					
9 Bit + P ³ + A ⁴	S8 ... S0	0	0	0	A	P	0	W ²				
9 Bit + P ³	S12 ... S4	S3	S2	S1	S0	P	0	W ²				
9 Bit + A ⁴	S12 ... S4	S3	S2	S1	S0	A	0	W ²				
9 Bit + P ³ + A ⁴	S12 ... S4	S3	S2	S1	S0	A	P	0	W ²			

Absolute

BiSS / SSI

DATA FORMAT Multiturn

Resolution	Data bits									
	T1 ... T12	T13 ... T21	T22	T23	T24	T25				
24 Bit ¹	M11 ... M0	S11 ... S2	S1	S0	0	W ²				
25 Bit ¹	M11 ... M0	S12 ... S3	S2	S1	S0	0	W ²			
26 Bit ¹	M11 ... M0	S13 ... S4	S3	S2	S1	S0	0	W ²		
Example for data format 24 Bit with the optional bits alarm und parity										
24 Bit + P ³	M11 ... M0	S11 ... S2	S1	S0	P	0	W ²			
24 Bit + A ⁴	M11 ... M0	S11 ... S2	S1	S0	A	0	W ²			
24 Bit + P ³ + A ⁴	M11 ... M0	S11 ... S2	S1	S0	A	P	0	W ²		

S0 ... S16 Data bits for resolution per revolution

M0 ... M11 Data bits for number of revolutions (only for multiturn)

¹ Options (Parity bit, alarm and parity bit, zero bit) on request

²W: from this data bit on the data iteration for multiplex starts

³Parity bit: Even Parity (The parity bit expands the data bits to an even number of 1-bits).
(Option)

⁴Alarm bit: is set to "1" when over temperature, under temperature, disc breakage and defect LED

SYNCHRONOUS-SERIAL TRANSFER (SSI)

Synchronous readout of the encoder data is according to the clock rate given by the SSI-counterpart.

The number of clock rates is determined by the type of encoder (singleturn resp. multiturn) and the configuration of the special Bits as defined.

For multiple transactions (the stored value is readout several times successively) a fixed clock rate per transaction must be kept (for singleturn 13 resp. 14 clocks, for multiturn 25 resp. 26 clocks).

- In the rest position, when the last clock brush has passed by more than 30µs, the data output is logically at "1".
- With the first descending clock edge the encoder data and the special bits are

loaded in the shift register of the encoder interface.

- With each ascending clock edge the data bits are serially readout, beginning with the MSB.
- At the end of the data transfer the data output is set to logically "0" for approx. 20µs. If within these 20µs a further clock brush reaches the encoder interface, the already transferred data is readout once again. This multiple transfer of the same data makes it possible to recognize transfer errors.
- After the 20µs the data output goes to its rest position, logically "1". Subsequently new encoder data can be readout.

Absolute

BiSS / SSI

ELECTRICAL CONNECTIONS

M23 connector (Conin), 12 pole / cable
Interface BI, SB, SG

Cable	M23 (Conin)	Signal
brown ³	1	0 V (supply voltage)
pink	2	Data
yellow	3	Clock
	4	N.C.
blue	5	$\overline{\text{Direction}}$ ¹
red	6	N.C.
violet	7	N.C.
white ³	8	DC 5/ 10 - 30 V
	9	N.C.
grey	10	$\overline{\text{Data}}$
green	11	$\overline{\text{Clock}}$
black	12	0 V-signal output ²

¹ $\overline{\text{Direction}}$: +U_B or unconnected = ascending code values with rotation cw
0 V = descending code values with rotation cw

² Connected with 0 V in the encoder.
Use this output to lay Direction on logical "0" if required.

³ use only thin wires ($\varnothing = 0.14$ mm)

ELECTRICAL CONNECTIONS

M23 connector (Conin), 12 pole / cable
Interface SC, BC

Cable	M23 (Conin)	Signal
brown ²	1	0 V (supply voltage)
pink	2	Data
yellow	3	Clock
white/green	4	A+
blue	5	$\overline{\text{Direction}}$ ¹
red/blue	6	B+
brown/green	7	A-
white ²	8	DC 5/10 - 30 V
grey/pink	9	B-
grey	10	$\overline{\text{Data}}$
green	11	$\overline{\text{Clock}}$
black	12	Sense

¹ $\overline{\text{Direction}}$: +U_B or unconnected = ascending code values with rotation cw
0 V = descending code values with rotation cw

² use only thin wires ($\varnothing = 0.14$ mm)

Absolute

BiSS / SSI

ELECTRICAL CONNECTIONS
M12 connector, 8 pole

Colour	Pin	Signal
white	1	DC 10 - 30 V
brown	2	0 V
	3	N.C.
green	4	Clock
pink	5	Data
yellow	6	Clock
blue	7	Direction ¹
grey	8	Data



View on connector

¹ Direction: + U_B or unconnected = ascending code values with rotation cw
0 V = descending code values with rotation cw

CONNECTION



M12, View on connector

DIMENSIONED DRAWINGS

see chapter "Dimensioned drawings AC 58", starting page 185

ORDERING INFORMATION

Type	Resolution ^{1,2}	Supply voltage ³	Flange, Protection, Shaft ^{4,8}	Interface ^{5,6}	Connection ⁷
<input type="checkbox"/>	<input type="text"/>	<input type="checkbox"/>	<input type="checkbox"/>	<input type="checkbox"/>	<input type="checkbox"/>
AC58	0010 10 Bit ST 0012 12 Bit ST 0013 13 Bit ST 0014 14 Bit ST 0017 17 Bit ST 0360 360 increments ST 0720 720 increments ST 1212 12 Bit MT + 12 Bit ST 1213 12 Bit MT + 13 Bit ST 1214 12 Bit MT + 14 Bit ST (BiSS) 1217 12 Bit MT + 17 Bit ST (BiSS) higher resolution on request	A DC 5 V E DC 10 - 30 V	S.41 Synchro, IP64, 6 mm S.71 Synchro, IP67, 6 mm K.42 Clamping, IP64, 10 mm K.46 Clamping, IP64, 9.52 mm K.72 Clamping, IP67, 10 mm K.76 Clamping, IP67, 9.52 mm F.46 Spring tether, IP64, hubshaft 9.52 mm, mounting with clamping ring front F.42 Spring tether, IP64, hubshaft 10 mm, mounting with clamping ring front F.47 Spring tether, IP64, hubshaft 12 mm, mounting with clamping ring front Q.46 Square, IP64, 9.52 mm Q.42 Square, IP64, 10 mm Q.76 Square, IP67, 9.52 mm Q.72 Square, IP67, 10 mm	BI BiSS BC BiSS (+SinCos 1Vpp) SB SSI binary SG SSI Gray SC SSI Gray (+SinCos 1Vpp)	A Cable, axial B Cable, radial C M23 connector (Conin), 12 pole, axial, cw D M23 connector (Conin), 12 pole, radial, cw G M23 connector (Conin), 12 pole, axial, ccw H M23 connector (Conin), 12 pole, radial, ccw 7 M12 connector, 8 pole, axial 8 M12 connector, 8 pole, radial

¹ Resolution 360 increments ST with Offset 76 (value range 76...435)

² Resolution 720 increments ST with Offset 152 (value range 152...871)

³ Max. cable length for DC 5 V: 10 m

⁴ Protection class IP67 not available in combination with preset key and LED display

⁵ Interface BiSS (+SinCos 1Vpp): not with connection "7" and "8" (M12)

⁶ Interface SSI Gray (+SinCos 1Vpp): not with connection "7" and "8" (M12)

⁷ Connection code "7" and "8" (M12) with square flange only for IP64 and 10x19,5 mm shaft

⁸ IP67 on cover with connector only if IP67 mating connector mounted properly.

Preferably available versions are printed in bold type.

ORDERING INFORMATION

Selection of cable length

Versions with cable outlet (connection A, B, E or F) are available with various lengths of cable. To order your desired cable length, please add the respective code to the end of your ordering code. Further cable lengths on request.

Code	Cable length
without code	1.5 m
-D0	3 m
-F0	5 m
-K0	10 m
-P0	15 m
-U0	20 m
-V0	25 m

ACCESSORIES

see chapter "Accessories", starting page 322

Absolute

Parallel



Synchro flange

- Compact design
- Aids for start up and operation: diagnostic LED, preset key with optical response (only with MT), status information
- Output Tristate short circuit-proof
- Gray or Binary code
- Encoder monitoring

TECHNICAL DATA
mechanical

Housing diameter	58 mm
Shaft diameter	6 mm / 10 mm (Solid shaft) 10 mm / 12 mm (Hub shaft)
Flange (Mounting of housing)	Synchro flange, Clamping flange, Tether, Square flange
Protection class shaft input (EN 60529)	IP64 or IP67
Protection class housing (EN 60529)	IP64 or IP67
Shaft load axial / radial	40 N / 60 N
Axial endplay of mounting shaft (hubshaft)	± 1.5 mm
Radial runout of mating shaft (hubshaft)	± 0.2 mm
Max. speed	max. 10 000 rpm (continuous), max. 12 000 rpm (short term)
Torque	0.01 Ncm
Moment of inertia	ca. 3.8×10^{-6} kgm ²
Vibration resistance (DIN EN 60068-2-6)	100 m/s ² (10 ... 2000 Hz)
Shock resistance (DIN EN 60068-2-27)	1000 m/s ² (6 ms)
Operating temperature	-40 °C ... +100 °C
Storage temperature	-40 °C ... +85 °C
Weight	approx. 350 g (ST) / 400 g (MT)
Connection ²	Cable, axial or radial M23 connector (Conin), 17 pole, axial or radial Sub-D connector, 37 pole

TECHNICAL DATA
electrical

Supply voltage	DC 10-30 V On request: DC 5 V
Max. current w/o load	200 mA (ST), 300 mA (MT)
Resolution singleturn	10 - 14 Bit Gray Excess: 360, 720 increments
Resolution multiturn	12 Bit
Output code	Binary, Gray, Gray Excess
Linearity	± ½ LSB
Output current	30 mA per Bit, short-circuit-proof
Control inputs	<u>L</u> atch, <u>D</u> irection, <u>T</u> ristate with ST, Tristate with MT

Absolute

Parallel

TECHNICAL DATA electrical (continued)

Alarm output	NPN-O.C., max. 5 mA
Status LED	Green = ok, red = alarm

Data output level

Supply voltage U_B	DC 5 V - 5 % +10 % ¹	DC 10 - 30 V
Output level High	≥ 3.5 V (30 mA) ≥ 3.9 V (10 mA)	$\geq U_B - 2.2$ V (30 mA) $\geq U_B - 1.8$ V (10 mA)
Output level Low	≤ 1.6 V (30 mA) ≤ 1.2 V (10 mA)	≤ 1.6 V (30 mA) ≤ 1.2 V (10 mA)
Rise time (1.5 m Cable)	≤ 0.1 μ s	≤ 0.2 μ s
Drop time (1.5 m Cable)	≤ 0.05 μ s	≤ 0.1 μ s

¹ on request

Control inputs

Input	Level logical (physical)	Function
$\overline{\text{Direction}}$	1 (+ U_B or open) 0 (0 V)	ascending code values when turning clockwise (cw) descending code values when turning clockwise (cw)
$\overline{\text{Latch}}$	1 (+ U_B or open) 0 (0 V)	encoder data continuously changing at output encoder data stored and constant at output
$\overline{\text{Tristate}}$ (with singleturn)	1 (+ U_B or open) 0 (0 V)	outputs active outputs at high impedance (Tristate mode)
Tristate (with multiturn)	1 (+ U_B) 0 (0 V or open)	outputs at high impedance (Tristate mode) outputs active

Typical actuating delay time 10 μ s with push-pull selection; when selected via O.C., an external pull-down resistor (1 K Ω) is required

Absolute

Parallel

ELECTRICAL CONNECTIONS

Singleturn, cable

Colour (PVC)	9 Bit / 360 incr.	10 Bit / 720 incr.	12 Bit	13 Bit	14 Bit
grey/pink	N.C.	N.C.	N.C.	N.C.	S0 (LSB)
brown/yellow	N.C.	N.C.	N.C.	S0 (LSB)	S1
brown/grey	N.C.	N.C.	S0 (LSB)	S1	S2
red/blue	N.C.	N.C.	S1	S2	S3
violet	N.C.	S0 (LSB)	S2	S3	S4
white/brown	S0 (LSB)	S1	S3	S4	S5
white/green	S1	S2	S4	S5	S6
white/yellow	S2	S3	S5	S6	S7
white/grey	S3	S4	S6	S7	S8
white/pink	S4	S5	S7	S8	S9
white/blue	S5	S6	S8	S9	S10
white/red	S6	S7	S9	S10	S11
white/black	S7	S8	S10	S11	S12
brown/green	S8 (MSB)	S9 (MSB)	S11 (MSB)	S12 (MSB)	S13 (MSB)
yellow	$\overline{\text{Tristate S0...S8}}$	$\overline{\text{Tristate S0...S9}}$	$\overline{\text{Tristate S0...S11}}$	$\overline{\text{Tristate S0...S12}}$	$\overline{\text{Tristate S0...S13}}$
pink	$\overline{\text{Latch}}$	$\overline{\text{Latch}}$	$\overline{\text{Latch}}$	$\overline{\text{Latch}}$	$\overline{\text{Latch}}$
green	$\overline{\text{Direction}}$	$\overline{\text{Direction}}$	$\overline{\text{Direction}}$	$\overline{\text{Direction}}$	$\overline{\text{Direction}}$
black	0 V	0 V	0 V	0 V	0 V
red	DC 5 V/ 10-30 V	DC 5 V/ 10-30 V	DC 5 V/ 10-30 V	DC 5 V/ 10-30 V	DC 5 V/ 10-30 V
brown	$\overline{\text{Alarm}}$	$\overline{\text{Alarm}}$	$\overline{\text{Alarm}}$	$\overline{\text{Alarm}}$	$\overline{\text{Alarm}}$

ELECTRICAL CONNECTIONS

Singleturn, M23 connector (Conin), 17 pole

Pin	9 Bit / 360 incr.	10 Bit / 720 incr.	12 Bit	13 Bit	14 Bit
1	S0 (LSB)	S0 (LSB)	S0 (LSB)	S12 (MSB)	S13 (MSB)
2	S1	S1	S1	S11	S12
3	S2	S2	S2	S10	S11
4	S3	S3	S3	S9	S10
5	S4	S4	S4	S8	S9
6	S5	S5	S5	S7	S8
7	S6	S6	S6	S6	S7
8	S7	S7	S7	S5	S6
9	S8 (MSB)	S8	S8	S4	S5
10	N.C.	S9 (MSB)	S9	S3	S4
11	N.C.	N.C.	S10	S2	S3
12	$\overline{\text{Tristate S0...S8}}$	$\overline{\text{Tristate S0...S9}}$	S11 (MSB)	S1	S2
13	$\overline{\text{Latch}}$	$\overline{\text{Latch}}$	$\overline{\text{Latch}}$	S0 (LSB)	S1
14	$\overline{\text{Direction}}$	$\overline{\text{Direction}}$	$\overline{\text{Direction}}$	$\overline{\text{Direction}}$	S0 (LSB)
15	0 V	0 V	0 V	0 V	0 V
16	DC 5 V/ 10-30 V	DC 5 V/ 10-30 V	DC 5 V/ 10-30 V	DC 5 V/ 10-30 V	DC 5 V/ 10-30 V
17	$\overline{\text{Alarm}}$	$\overline{\text{Alarm}}$	$\overline{\text{Alarm}}$	$\overline{\text{Latch/Alarm}}$	$\overline{\text{Latch/Alarm}}$

Absolute

Parallel

ELECTRICAL CONNECTIONS

Multiturn, cable

Cable (TPE)	10 cm cable with Sub-D connector, 37 pole		Cable (TPE)	10 cm cable with Sub-D connector, 37 pole	
Colour	Pin	Connection	Colour	Pin	Connection
brown	2	S0	white/blue	14	M4 ¹
green	21	S1	brown/blue	33	M5 ¹
yellow	3	S2	white/red	15	M6 ¹
grey	22	S3	brown/red	34	M7 ¹
pink	4	S4	white/black	16	M8 ²
violet	23	S5	brown/black	35	M9 ²
grey/pink	5	S6	grey/green	17	M10 ²
red/blue	24	S7	yellow/grey	36	M11 ²
white/green	6	S8	pink/green	18	Alarm
brown/green	25	S9	yellow/pink	10	Direction
white/yellow	7	S10	green/blue	30	Latch
yellow/brown	26	S11	yellow/blue	12	Tristate
white/grey	8	M0	red (0.5mm ²)	13	DC 10-30 V
grey/brown	27	M1	white (0.5mm ²)	31	DC 10-30 V
white/pink	9	M2	blue (0.5mm ²)	1	0 V
pink/brown	28	M3	black (0.5mm ²)	20	0 V

¹ N. C. with resolution 16 Bit (4 Bit MT)² N. C. with resolution 16 Bit or 20 Bit (4 or 8 Bit MT)

DIMENSIONED DRAWINGS

see chapter "Dimensioned drawings AC 58", starting page 185

ORDERING INFORMATION

Type	Resolution ^{1,2}	Supply voltage	Flange, Protection, Shaft ^{3,7}	Interface	Connection ^{4,5,6}
<input type="checkbox"/>	<input type="text"/>	<input type="checkbox"/>	<input type="text"/>	<input type="checkbox"/>	<input type="text"/>
AC58	0010 10 Bit ST 0012 12 Bit ST 0013 13 Bit ST 0014 14 Bit ST 0360 360 increments ST 0720 720 increments ST 0412 4 Bit MT + 12 Bit ST 0812 8 Bit MT + 12 Bit ST 1212 12 Bit MT + 12 Bit ST	E DC 10 - 30 V	S.41 Synchro, IP64, 6 mm S.71 Synchro, IP67, 6 mm K.42 Clamping, IP64, 10 mm K.46 Clamping, IP64, 9.52 mm K.72 Clamping, IP67, 10 mm K.76 Clamping, IP67, 9.52 mm F.46 Spring tether, IP64, hubs-haft 9.52 mm, mounting with clamping ring front F.42 Spring tether, IP64, hubs-haft 10 mm, mounting with clamping ring front F.47 Spring tether, IP64, hubs-haft 12 mm, mounting with clamping ring front Q.46 Square, IP64, 9.52 mm Q.42 Square, IP64, 10 mm Q.76 Square, IP67, 9.52 mm Q.72 Square, IP67, 10 mm	PB Parallel binary PG Parallel Gray	A Cable, axial B Cable, radial U M23 connector (Conin), 17 pole, axial, ccw V M23 connector (Conin), 17 pole, radial, ccw W M23 connector (Conin), 17 pole, axial, cw Y M23 connector (Conin), 17 pole, radial, cw A-A1-F 0,1 m cable with Sub-D connector, 37 pole, axial B-B1-F 0,1 m cable with Sub-D connector, 37 pole, radial

¹ Resolution 360 increments ST with Offset 76 (value range 76...435)

² Resolution 720 increments ST with Offset 152 (value range 152...871)

³ Protection class IP67 not available in combination with preset key and LED display

⁴ Connection code "A", "B" (cable): ST and MT

⁵ Connection code "U", "V", "W", "Y" (M23 connector): only ST

⁶ Connection code "A-A1-F" and "B-B1-F" (Sub-D connector): only MT

⁷ IP67 on cover with connector only if IP67 mating connector mounted properly.

Preferably available versions are printed in bold type.

ORDERING INFORMATION

Selection of cable length

Versions with cable outlet (connection A, B, E or F) are available with various lengths of cable. To order your desired cable length, please add the respective code to the end of your ordering code. Further cable lengths on request.

Code	Cable length
without code	1.5 m
-D0	3 m
-F0	5 m
-K0	10 m
-P0	15 m
-U0	20 m
-V0	25 m

ACCESSORIES

see chapter "Accessories", starting page 322

Absolute

Profibus

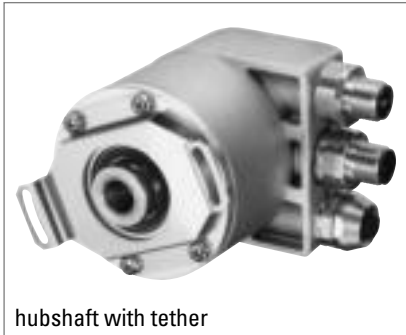

hubshaft with tether

TECHNICAL DATA mechanical

- Diagnostic LED
- Cable or M12 connector
- Output of speed, acceleration
- Programmable: Resolution, Preset, Direction, Operation time
- Option: Display "tico"
- Address via interface parameterizable (optional)



Housing diameter	58 mm
Shaft diameter	6 mm / 10 mm (Solid shaft) 10 mm / 12 mm (Hub shaft)
Flange (Mounting of housing)	Synchro flange, Clamping flange, Tether, Square flange
Protection class shaft input (EN 60529)	IP64 or IP67
Protection class housing (EN 60529)	IP67
Shaft load axial / radial	40 N / 60 N
Axial endplay of mounting shaft (hubshaft)	± 1.5 mm
Radial runout of mating shaft (hubshaft)	± 0.2 mm
Max. speed	max. 10 000 rpm (continuous), max. 12 000 rpm (short term)
Torque	0.5 Ncm
Moment of inertia	ca. 3.8 x 10 ⁻⁶ kgm ²
Vibration resistance (DIN EN 60068-2-6)	100 m/s ² (10 ... 500 Hz)
Shock resistance (DIN EN 60068-2-27)	1000 m/s ² (6 ms)
Operating temperature	-40 °C ... +85 °C
Storage temperature	-40 °C ... +85 °C
Material shaft	Stainless Steel
Material housing	Aluminum
Weight	approx. 350 g (ST) / 400 g (MT)
Connection	Bus cover with 3 sealed cable exits Bus cover with 2x M23 connectors (Conin), 12 pole Bus cover with 3x M12 connector Bus cover with 2 sealed cable exits + 1 x M12 connector for "tico" display, 4 pole

TECHNICAL DATA electrical

General design	as per DIN EN 61010-1, protection class III, contamination level 2, overvoltage class II
Supply voltage	DC 10-30 V
Max. current w/o load	220 mA (ST), 250 mA (MT)
EMC	EN 61326: Class A

Absolute

Profibus

TECHNICAL DATA electrical (continued)

Resolution singleturn	10 - 14 Bit
Resolution multiturn	12 Bit
Output code	Binary
Drives	RS 485
Linearity	± ½ LSB (± 1 LSB for resolution 13, 14, 25, 26 Bit)
Profile/ protocol	Profibus DP with encoder profile class C2 (parameterizable)
Programmable	Resolution, Preset, Direction
Integrated special functions	Speed, Acceleration, Operating time
Baud rate	is automatically set within a range of 9.6 Kbaud through 12 MBaud
Device address	adjustable with DIP switches, via fieldbus (optional)
Bus termination resistor	set via DIP switches

STARTUP (The encoder can be easily and quickly installed and programmed with the GSD file.)

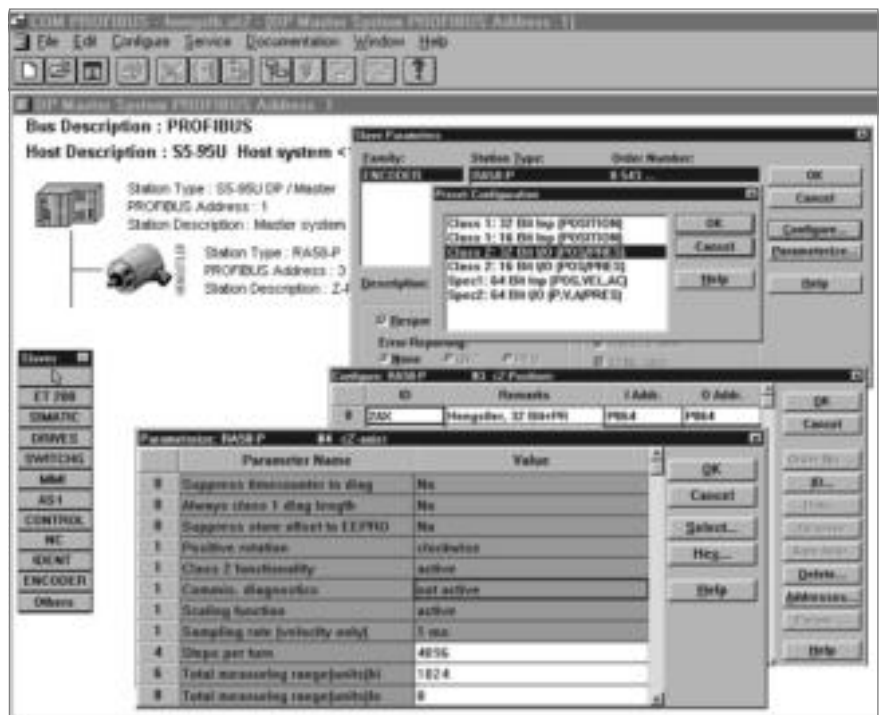

Absolute

Profibus

ELECTRICAL CONNECTIONS
Bus cover with 2x M23 connectors
(Conin), 12 pole

Pin	IN (pins)	OUT (socket)	Description
1		GND ¹	Data Ground (M5V) ¹
2	A	A	Receive/Transmit Data-Negative (A)
3			
4	B	B	Receive/Transmit Data-Positive (B)
5			
6		VCC ¹	+5 V signal output (P5V) ¹
7	DC 10 - 30 V	DC 10 - 30 V	Supply voltage +U _B (P24)
8	0 V	0 V	Supply voltage Ground (M24)
9			
10			
11			
12			
screen	screen	screen	screen connected with encoder housing

¹ can be used as power supply for an external bus termination resistor

ELECTRICAL CONNECTIONS
Bus cover with 3x M12

Pin	Connector 1	Connector 2	Socket
1		UB in	+5 V signal output (P5V) ¹
2	A in		A out
3		0 V in	Data Ground (M5V) ¹
4	B in		B out
5	screen	screen	screen

¹ can be used as power supply for an external bus termination resistor

ELECTRICAL CONNECTIONS
Bus cover with 3 sealed cable exits

Connecting Terminal	Signal
1	UB in (DC 10 - 30V)
2	0 V in
3	UB out
4	0 V out
5	B in
6	A in
7	B out
8	A out

DIMENSIONED DRAWINGS

see chapter "Dimensioned drawings AC 58", starting page 185

ORDERING INFORMATION

Type	Resolution	Supply voltage	Flange, Protection, Shaft	Interface	Connection
<input type="checkbox"/>	<input type="checkbox"/>	<input type="checkbox"/>	<input type="checkbox"/>	<input type="checkbox"/>	<input type="checkbox"/>
AC58	0010 10 Bit ST 0012 12 Bit ST 0013 13 Bit ST 0014 14 Bit ST 1212 12 Bit MT + 12 Bit ST 1213 12 Bit MT + 13 Bit ST 1214 12 Bit MT + 14 Bit ST	E DC 10 - 30 V	S.41 Synchro, IP64, 6 mm S.71 Synchro, IP67, 6 mm K.42 Clamping, IP64, 10 mm K.46 Clamping, IP64, 9.52 mm K.72 Clamping, IP67, 10 mm K.76 Clamping, IP67, 9.52 mm F.46 Spring tether, IP64, hubs-haft 9.52 mm, mounting with clamping ring front F.42 Spring tether, IP64, hubs-haft 10 mm, mounting with clamping ring front F.47 Spring tether, IP64, hubs-haft 12 mm, mounting with clamping ring front Q.46 Square, IP64, 9.52 mm Q.42 Square, IP64, 10 mm Q.76 Square, IP67, 9.52 mm Q.72 Square, IP67, 10 mm	DP Profibus	I Bus cover with 2x M23 connector (Conin), 12 pole, radial, cw R Bus cover with 3x M12 T Bus cover with 2 sealed cable exits + 1 x M12 connector for "tico" display, 4 pole Z Bus cover with 3 sealed cable exits

Preferably available versions are printed in bold type.

ACCESSORIES

see chapter "Accessories", starting page 322

Absolute

CANopen



Clamping flange

TECHNICAL DATA mechanical

- Diagnostic LED
- Programmable: Resolution, Preset, Offset, Direction
- Output of speed, acceleration
- Operation timer
- Option: Display "tico"
- Address and baud rate via interface parameterizable (optional)



CANopen



Housing diameter	58 mm
Shaft diameter	6 mm / 10 mm (Solid shaft) 10 mm / 12 mm (Hub shaft)
Flange (Mounting of housing)	Synchro flange, Clamping flange, Tether, Square flange
Protection class shaft input (EN 60529)	IP64 or IP67
Protection class housing (EN 60529)	Connection bus cover: IP67 Connection cable or M23 (conin): IP64 (IP67 optional)
Shaft load axial / radial	40 N / 60 N
Axial endplay of mounting shaft (hubshaft)	± 1.5 mm
Radial runout of mating shaft (hubshaft)	± 0.2 mm
Max. speed	max. 10 000 rpm (continuous), max. 12 000 rpm (short term)
Torque	0.5 Ncm
Moment of inertia	ca. 3.8 x 10 ⁻⁶ kgm ²
Vibration resistance (DIN EN 60068-2-6)	100 m/s ² (10 ... 500 Hz)
Shock resistance (DIN EN 60068-2-27)	1000 m/s ² (6 ms)
Operating temperature	-40 °C ... +85 °C
Storage temperature	-40 °C ... +85 °C
Material shaft	Stainless Steel
Material housing	Aluminum
Weight	approx. 350 g (ST) / 400 g (MT)
Connection	Cable, axial or radial M23 connector (Conin), 12 pole, axial or radial Bus cover with 3 sealed cable exits Bus cover with 2x M23 connectors (Conin), 9 pole Bus cover with 2 sealed cable exits + 1 x M12 connector for "tico" display, 4 pole

TECHNICAL DATA electrical

General design	as per DIN EN 61010-1, protection class III, contamination level 2, overvoltage class II
Supply voltage	DC 10-30 V
Max. current w/o load	220 mA (ST), 250 mA (MT)
EMC	EN 61326: Class A

Absolute

CANopen

TECHNICAL DATA electrical (continued)

Resolution singleturn	10 - 16 Bit
Resolution multiturn	12 Bit
Output code	Binary
Linearity	± ½ LSB (± 1 LSB for resolution 13, 14, 25, 26 Bit)
Profile/ protocol	CANopen according to DS 301 with profile DSP 406, programmable encoder according class C2
Programmable	Resolution, Preset, Offset, Direction
Integrated special functions	Speed, Acceleration, Limit values, Operating time
Baud rate	set via DIP switches within a range of 10 through 1000 Kbit/s
Bus termination resistor	set via DIP switches
Updating of values	every millisecond (adjustable), on request
Basic identifier	set via DIP switches

ELECTRICAL CONNECTIONS Bus cover with 2x M23 connectors (Conin), 9 pole

M23-PIN (Conin)	Pin insert (IN)	Socket insert (OUT)
1	CAN in +	CAN out +
2	CAN in -	CAN out-
3	CAN GND in	CAN GND out
4	N.C.	N.C.
5	N.C.	N.C.
6	N.C.	N.C.
7	UB in	UB out
8	0 V in	0 V out
9	N.C.	N.C.
screen	screen ¹	screen ¹

¹ screen connected with encoder housing

ELECTRICAL CONNECTIONS M23 connector (Conin), 12 pole / cable

M23-Pin (Conin)	TPE cable	Cable pairs	Signal
7	yellow	Pair 1	CAN in+
2	green		CAN in -
4	pink	Pair 2	CAN out +
5	grey		CAN out -
3	blue		CAN GND in
11	brown		CAN GND out
12	white	Pair 3	UB in
10	brown		0 V in
screen	screen		screen

Absolute

CANopen

ELECTRICAL CONNECTIONS
Bus cover with 3 sealed cable exits

Connecting block KL 1 (10 pole)

No.	Signal name
1	UB in (DC 10-30V)
2	0 V in
3	CAN in - (dominant L)
4	CAN in + (dominant H)
5	CAN GND in
6	CAN GND out
7	CAN out + (dominant H)
8	CAN out - (dominant L)
9	0 V out
10	UB out (DC 10-30V)

DIMENSIONED DRAWINGS

see chapter "Dimensioned drawings AC 58", starting page 185

ORDERING INFORMATION

Type	Resolution	Supply voltage	Flange, Protection, Shaft ¹	Interface	Connection
<input type="checkbox"/>	<input type="text"/>	<input type="checkbox"/>	<input type="checkbox"/>	<input type="checkbox"/>	<input type="checkbox"/>
AC58	0010 10 Bit ST 0012 12 Bit ST 0013 13 Bit ST 0014 14 Bit ST 0016 16 Bit ST 1212 12 Bit MT + 12 Bit ST 1213 12 Bit MT + 13 Bit ST 1214 12 Bit MT + 14 Bit ST	E DC 10 - 30 V	S.41 Synchro, IP64, 6 mm S.71 Synchro, IP67, 6 mm K.42 Clamping, IP64, 10 mm K.46 Clamping, IP64, 9.52 mm K.72 Clamping, IP67, 10 mm K.76 Clamping, IP67, 9.52 mm F.46 Spring tether, IP64, hubs-haft 9.52 mm, mounting with clamping ring front F.42 Spring tether, IP64, hubs-haft 10 mm, mounting with clamping ring front F.47 Spring tether, IP64, hubs-haft 12 mm, mounting with clamping ring front Q.46 Square, IP64, 9.52 mm Q.42 Square, IP64, 10 mm Q.76 Square, IP67, 9.52 mm Q.72 Square, IP67, 10 mm	OL CANopen OC CANopen - on request -	A Cable, axial B Cable, radial C M23 connector (Conin), 12 pole, axial, cw D M23 connector (Conin), 12 pole, radial, cw G M23 connector (Conin), 12 pole, axial, ccw H M23 connector (Conin), 12 pole, radial, ccw I Bus cover with 2x M23 connector (Conin), 9 pole, radial, cw T Bus cover with 2 sealed cable exits + 1 x M12 connector for "tico" display, 4 pole Z Bus cover with 2 sealed cable exits

¹ Protection class IP67 in combination with connection "A" - "H": Version without DIP switches and LED. Setting over fieldbus

Preferably available versions are printed in bold type.

Absolute**CANopen****ORDERING INFORMATION****Selection of cable length**

Versions with cable outlet (connection A, B, E or F) are available with various lengths of cable. To order your desired cable length, please add the respective code to the end of your ordering code. Further cable lengths on request.

Code	Cable length
without code	1.5 m
-D0	3 m
-F0	5 m
-K0	10 m
-P0	15 m
-U0	20 m
-V0	25 m

ACCESSORIES

see chapter "Accessories", starting page 322

Absolute

CANlayer2



Clamping flange

TECHNICAL DATA mechanical

- Diagnostic LED
- Poll and auto mode
- Programmable: Direction, limit values
- Option: Display "tico"



Housing diameter	58 mm
Shaft diameter	6 mm / 10 mm (Solid shaft) 10 mm / 12 mm (Hub shaft)
Flange (Mounting of housing)	Synchro flange, Clamping flange, Tether, Square flange
Protection class shaft input (EN 60529)	IP64 or IP67
Protection class housing (EN 60529)	IP67 or IP64 (IP67 optional)
Shaft load axial / radial	40 N / 60 N
Axial endplay of mounting shaft (hubshaft)	± 1.5 mm
Radial runout of mating shaft (hubshaft)	± 0.2 mm
Max. speed	max. 10 000 rpm (continuous), max. 12 000 rpm (short term)
Torque	0.5 Ncm
Moment of inertia	ca. 3.8×10^{-6} kgm ²
Vibration resistance (DIN EN 60068-2-6)	100 m/s ² (10 ... 500 Hz)
Shock resistance (DIN EN 60068-2-27)	1000 m/s ² (6 ms)
Operating temperature	-40 °C ... +85 °C
Storage temperature	-40 °C ... +85 °C
Material shaft	Stainless Steel
Material housing	Aluminum
Weight	approx. 350 g (ST) / 400 g (MT)
Connection	Cable, axial or radial M23 connector (Conin), 12 pole, axial or radial Bus cover with 3 sealed cable exits Bus cover with 2x M23 connectors (Conin), 9 pole Bus cover with 2 sealed cable exits + 1 x M12 connector for "tico" display, 4 pole

TECHNICAL DATA electrical

General design	as per DIN EN 61010-1, protection class III, contamination level 2, overvoltage class II
Supply voltage	DC 10-30 V
Max. current w/o load	220 mA (ST), 250 mA (MT)
EMC	EN 61326: Class A
Resolution singleturn	10 - 14 Bit

Absolute

CANlayer2

TECHNICAL DATA electrical (continued)

Resolution multitrans	12 Bit
Output code	Binary
Linearity	$\pm \frac{1}{2}$ LSB (± 1 LSB for resolution 13, 14, 25, 26 Bit)
Profile/ protocol	CAN 2.0 A
Programmable	Direction, Limit values
Baud rate	set via DIP switches within a range of 10 through 1000 Kbit/s
Bus termination resistor	set via DIP switches
Updating of values	every millisecond
Basic identifier	set via DIP switches

ELECTRICAL CONNECTIONS Bus cover with 2x M23 connectors (Conin), 9 pole

M23-PIN (Conin)	Pin insert (IN)	Socket insert (OUT)
1	CAN in +	CAN out +
2	CAN in -	CAN out-
3	CAN GND in	CAN GND out
4	N.C.	N.C.
5	N.C.	N.C.
6	N.C.	N.C.
7	UB in	UB out
8	0 V in	0 V out
9	N.C.	N.C.
screen	screen ¹	screen ¹

¹ screen connected with encoder housing

ELECTRICAL CONNECTIONS M23 connector (Conin), 12 pole / cable

M23-Pin (Conin)	TPE cable	Cable pairs	Signal
7	yellow	Pair 1	CAN in+
2	green		CAN in -
4	pink	Pair 2	CAN out +
5	grey		CAN out -
3	blue		CAN GND in
11	brown		CAN GND out
12	white	Pair 3	UB in
10	brown		0 V in
screen	screen		screen

Absolute

CANlayer2

ELECTRICAL CONNECTIONS
Bus cover with 3 sealed cable exits

Connecting block KL 1 (10 pole)

No.	Signal name
1	UB in (DC 10-30V)
2	0 V in
3	CAN in - (dominant L)
4	CAN in + (dominant H)
5	CAN GND in
6	CAN GND out
7	CAN out + (dominant H)
8	CAN out - (dominant L)
9	0 V out
10	UB out (DC 10-30V)

DIMENSIONED DRAWINGS

see chapter "Dimensioned drawings AC 58", starting page 185

ORDERING INFORMATION

Type	Resolution	Supply voltage	Flange, Protection, Shaft ¹	Interface	Connection
<input type="checkbox"/>	<input type="checkbox"/>	<input type="checkbox"/>	<input type="checkbox"/>	<input type="checkbox"/>	<input type="checkbox"/>
AC58	0010 10 Bit ST 0012 12 Bit ST 0013 13 Bit ST 0014 14 Bit ST 1212 12 Bit MT + 12 Bit ST 1213 12 Bit MT + 13 Bit ST 1214 12 Bit MT + 14 Bit ST	E DC 10 - 30 V	S.41 Synchro, IP64, 6 mm S.71 Synchro, IP67, 6 mm K.42 Clamping, IP64, 10 mm K.46 Clamping, IP64, 9.52 mm K.72 Clamping, IP67, 10 mm K.76 Clamping, IP67, 9.52 mm F.46 Spring tether, IP64, hubs-haft 9.52 mm, mounting with clamping ring front F.42 Spring tether, IP64, hubs-haft 10 mm, mounting with clamping ring front F.47 Spring tether, IP64, hubs-haft 12 mm, mounting with clamping ring front Q.46 Square, IP64, 9.52 mm Q.42 Square, IP64, 10 mm Q.76 Square, IP67, 9.52 mm Q.72 Square, IP67, 10 mm	CL CANLayer2	A Cable, axial B Cable, radial C M23 connector (Conin), 12 pole, axial, cw D M23 connector (Conin), 12 pole, radial, cw G M23 connector (Conin), 12 pole, axial, ccw H M23 connector (Conin), 12 pole, radial, ccw I Bus cover with 2x M23 connector (Conin), 9 pole, radial, cw T Bus cover with 2 sealed cable exits + 1 x M12 connector for "tico" display, 4 pole Z Bus cover with 2 sealed cable exits

¹ Protection class IP67 not available in combination with cable and M23 connector (Conin) for connection code "A" - "H"

Preferably available versions are printed in bold type.

Absolute**CANlayer2****ORDERING INFORMATION**
Selection of cable length

Versions with cable outlet (connection A, B, E or F) are available with various lengths of cable. To order your desired cable length, please add the respective code to the end of your ordering code. Further cable lengths on request.

Code	Cable length
without code	1.5 m
-D0	3 m
-F0	5 m
-K0	10 m
-P0	15 m
-U0	20 m
-V0	25 m

ACCESSORIES

see chapter "Accessories", starting page 322

Absolute

DeviceNet



Synchro flange

- Programmable: Resolution, Preset, Direction
- Allan-Bradley compatible
- Scalable
- Preset function
- Diagnostic LED
- Option: Display "tico"



TECHNICAL DATA mechanical

Housing diameter	58 mm
Shaft diameter	6 mm / 10 mm (Solid shaft) 10 mm / 12 mm (Hub shaft)
Flange (Mounting of housing)	Synchro flange, Clamping flange, Tether, Square flange
Protection class shaft input (EN 60529)	IP64 or IP67
Protection class housing (EN 60529)	IP67
Shaft load axial / radial	40 N / 60 N
Axial endplay of mounting shaft (hubshaft)	± 1.5 mm
Radial runout of mating shaft (hubshaft)	± 0.2 mm
Max. speed	max. 10 000 rpm (continuous), max. 12 000 rpm (short term)
Torque	0.5 Ncm
Moment of inertia	ca. 3.8×10^{-6} kgm ²
Vibration resistance (DIN EN 60068-2-6)	100 m/s ² (10 ... 500 Hz)
Shock resistance (DIN EN 60068-2-27)	1000 m/s ² (6 ms)
Operating temperature	-40 °C ... +85 °C
Storage temperature	-40 °C ... +85 °C
Material shaft	Stainless Steel
Material housing	Aluminum
Weight	approx. 350 g (ST) / 400 g (MT)
Connection	Bus cover with 2 sealed cable exits Bus cover with 2 sealed cable exits + 1 x M12 connector for "tico" display, 4 pole Bus cover with 1x M12 connectors (Conin), 5 pole

TECHNICAL DATA electrical

General design	as per DIN EN 61010-1, protection class III, contamination level 2, overvoltage class II
Supply voltage	DC 10-30 V
Max. current w/o load	220 mA (ST), 250 mA (MT)
EMC	Noise emission according to EN 50081-2 Immunity to interference according to EN 50082-2

Absolute

DeviceNet

TECHNICAL DATA electrical (continued)

EMC	EN 61326: Class A
Resolution singleturn	10 - 14 Bit
Resolution multiturn	12 Bit
Output code	Binary
Interface	CAN High-Speed according to ISO/DIS 11898 CAN specification 2.0 A (11-Bit-Identifier)
Linearity	$\pm \frac{1}{2}$ LSB (± 1 LSB for resolution 13, 14, 25, 26 Bit)
Profile/ protocol	DeviceNet according to Rev. 2.0, programmable encoder
Programmable	Resolution, Preset, Direction
Baud rate	set via DIP switches to 125, 250, 500 Kbaud
Bus termination resistor	set via DIP switches
Updating of values	every 5 Milliseconds
MAC-ID	set via DIP switches

RECOMMENDED DATA TRANSFER Lead type A

Shaft resistance	135...165 Ω (3...20MHz)
Operating capacity	< 30pF/m
Loop impedance	< 110 Ω /km
Strand diameter	> 0.64 mm
Strand cross section	> 0.34 mm ²

Transfer speeds

Segment length	kbit/s
500 m	125
250 m	250
100 m	500

STARTUP (the encoder can be easily and quickly installed and programmed with the EDS file)



Absolute

DeviceNet

ELECTRICAL CONNECTIONS

Bus cover with 2 sealed cable exits

Terminals	
No.	Signal name
1	UB in (DC 10 - 30V)
2	0 V in
3	CAN-L
4	CAN-H
5	DRAIN
6	DRAIN
7	DRAIN
8	CAN-L
9	0 V out
10	UB out (DC 10 - 30V)

ELECTRICAL CONNECTIONS

Bus cover with 1x M12, 5 pole

Pin	Connector	Colour
1	UB in (DC 10 - 30V)	white
2	0 V in	blue
3	CAN-L	green/yellow
4	CAN-H	black
5	DRAIN	brown

DIMENSIONED DRAWINGS

see chapter "Dimensioned drawings AC 58", starting page 185

ORDERING INFORMATION

Type	Resolution	Supply voltage	Flange, Protection, Shaft	Interface	Connection
<input type="checkbox"/>	<input type="checkbox"/>	<input type="checkbox"/>	<input type="checkbox"/>	<input type="checkbox"/>	<input type="checkbox"/>
AC58	0010 10 Bit ST 0012 12 Bit ST 0013 13 Bit ST 0014 14 Bit ST 1212 12 Bit MT + 12 Bit ST 1213 12 Bit MT + 13 Bit ST 1214 12 Bit MT + 14 Bit ST	E DC 10 - 30 V	S.41 Synchro, IP64, 6 mm S.71 Synchro, IP67, 6 mm K.42 Clamping, IP64, 10 mm K.46 Clamping, IP64, 9.52 mm K.72 Clamping, IP67, 10 mm K.76 Clamping, IP67, 9.52 mm F.46 Spring tether, IP64, hubs-haft 9.52 mm, mounting with clamping ring front F.42 Spring tether, IP64, hubs-haft 10 mm, mounting with clamping ring front F.47 Spring tether, IP64, hubs-haft 12 mm, mounting with clamping ring front Q.46 Square, IP64, 9.52 mm Q.42 Square, IP64, 10 mm Q.76 Square, IP67, 9.52 mm Q.72 Square, IP67, 10 mm	VD DeviceNet	S Bushaube mit 1x M12-Stecker, 5-polig, radial T Bus cover with 2 sealed cable exits + 1 x M12 connector for "tico" display, 4 pole Z Bus cover with 2 sealed cable exits

Preferably available versions are printed in bold type.

ACCESSORIES

see chapter "Accessories", starting page 322

Absolute

Interbus



hubshaft with tether

- Resolution programmable (K3)
- Resolution up to 24 Bit
- Preset (K3)
- Direction (K3)
- Diagnostic LED



TECHNICAL DATA mechanical

Housing diameter	58 mm
Shaft diameter	6 mm / 10 mm (Solid shaft) 10 mm / 12 mm (Hub shaft)
Flange (Mounting of housing)	Synchro flange, Clamping flange, Tether, Square flange
Protection class shaft input (EN 60529)	IP64 or IP67
Protection class housing (EN 60529)	Connection bus cover: IP67 Connection cable or M23 (conin): IP64 (IP67 optional)
Shaft load axial / radial	40 N / 60 N
Max. speed	max. 10 000 rpm (continuous), max. 12 000 rpm (short term)
Torque	0.5 Ncm
Moment of inertia	ca. 3.8×10^{-6} kgm ²
Vibration resistance (DIN EN 60068-2-6)	100 m/s ² (10 ... 500 Hz)
Shock resistance (DIN EN 60068-2-27)	1000 m/s ² (6 ms)
Operating temperature	-40 °C ... +70 °C
Storage temperature	-40 °C ... +85 °C
Material shaft	Stainless Steel
Material housing	Aluminum
Weight	approx. 350 g (ST) / 400 g (MT)
Connection	Bus cover with 3 sealed cable exits Bus cover with 2x M23 connectors (Conin), 9 pole Cable 1.5 m with M23 connector (Conin), 12 pole, axial or radial

TECHNICAL DATA electrical

General design	as per DIN EN 61010-1, protection class III, contamination level 2, overvoltage class II
Supply voltage	DC 10-30 V
Max. current w/o load	220 mA (ST, recommended external fuse: T 0.25 A), 250 mA (MT, recommended external fuse: T 0.25 A)
EMC	Noise emission according to EN 50081-2 Immunity to interference according to EN 50082-2
Resolution singleturn	10 - 12 Bit
Resolution multiturn	12 Bit
Output code	32 Bit binary
Linearity	$\pm \frac{1}{2}$ LSB

Absolute

Interbus

TECHNICAL DATA electrical (continued)

Profile/ protocol	ENCOM-Profil K3 = ID-Code 37, K2 = ID-Code 36
Programmable	Resolution, Preset, Offset, Direction
Output current ¹	max. 4.5 A for bus cover with 2x M23 (recommended external fuse: T 4.5 A) max. 2 A for all other connections (recommended external fuse: T 2 A)
Baud rate	500 Kbaud
Updating of values	every 600 µs

¹ Current with looped through voltage supply

DATA FORMAT Interbus K2/K3

	Differential signals (RS485) ENCOM profile K3, K2, 32 Bit, binary process data				
Data format	µpi-address	0	1	2	3
(as per Phoenix)	Byte-No.	3	2	1	0
ID-Code K2	36H (= 54 decimal)				
ID-Code K3	37H (= 55 decimal)				

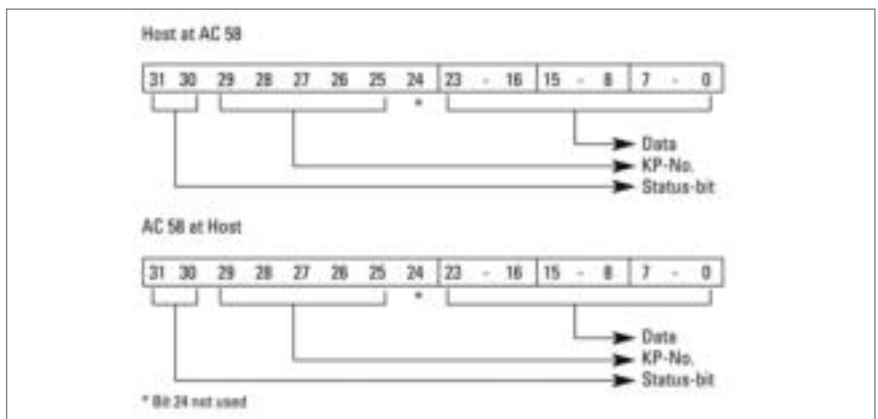

PROGRAMMABLE FUNKTIONS for Interbus K3

Function (Programming directly via the bus through transfer of configuration parameters)	Preset values (manufacturer's standard settings)	Customer-specific parameters
Code sequence for clockwise (cw) rotation	ascending	
Offset (KP-No. 05)	0	
Preset value (KP-No. 04)	0	
Scaling faktor (KP-No. 08)	1 ¹	

¹ maximum resolution

Absolute

Interbus

ELECTRICAL CONNECTIONS

Cable with M23 connector (Conin), 12 pole
(Standard according to ENCOM for remote installation bus)

Plug pin	Signal
1	D02
2	$\overline{D02}$
3	DI 2
4	$\overline{DI 2}$
5	D01
6	$\overline{D01}$
7	DI 1
8	$\overline{DI1}$
9	\overline{RBST}
10	GND- signal output ¹
11	0 V (supply voltage)
12	DC 10 - 30 V

¹ Due to electrical isolation not identical with 0 V (supply voltage) identisch; used by T-manifold to set the RBST input logical on "0"

ELECTRICAL CONNECTIONS

Bus cover with 2x M23 connector (Conin), 9 pole
(Standard according to ENCOM for remote installation bus)

Pin	IN (9 pole pins)	OUT (9 pole socket)
1	D01	D02
2	$\overline{D01}$	$\overline{D02}$
3	DI 1	DI 2
4	$\overline{DI1}$	$\overline{DI2}$
5	GND- signal output ¹	GND- signal output ¹
6	PE ²	PE ²
7	DC10 - 30 V (SELV)	DC10 - 30 V (SELV)
8	0 V (supply voltage)	0 V (supply voltage)
9	N.C.	\overline{RBST}

¹ Due to electrical isolation not identical with 0 V (supply voltage) identisch; used by T-manifold to set the RBST input logical on "0"

² Functional earthing; connected with the encoder housing

ELECTRICAL CONNECTIONS

Bus cover with 3 sealed cable exits

Connection clamp (12 pole)	
1	UB +
2	GND
3	DI1+
4	DI1-
5	D01+
6	D01-
7	D02+
8	D02-
9	DI2+
10	DI2-
11	RBST
12	GND

Absolute

Interbus

DIMENSIONED DRAWINGS

see chapter "Dimensioned drawings AC 58", starting page 185

ORDERING INFORMATION

Type	Resolution	Supply voltage	Flange, Protection, Shaft ¹	Interface	Connection
<input type="checkbox"/>	<input type="text"/>	<input type="checkbox"/>	<input type="text"/>	<input type="checkbox"/>	<input type="text"/>
AC58	0010 10 Bit ST 0012 12 Bit ST 1212 12 Bit MT + 12 Bit ST	E DC 10 - 30 V	S.41 Synchro, IP64, 6 mm S.71 Synchro, IP67, 6 mm K.42 Clamping, IP64, 10 mm K.46 Clamping, IP64, 9.52 mm K.72 Clamping, IP67, 10 mm K.76 Clamping, IP67, 9.52 mm F.46 Spring tether, IP64, hubs-haft 9.52 mm, mounting with clamping ring front F.42 Spring tether, IP64, hubs-haft 10 mm, mounting with clamping ring front F.47 Spring tether, IP64, hubs-haft 12 mm, mounting with clamping ring front Q.46 Square, IP64, 9.52 mm Q.42 Square, IP64, 10 mm Q.76 Square, IP67, 9.52 mm Q.72 Square, IP67, 10 mm	I2 Interbus K2 K3 Interbus K3	I Bus cover with 2x M23 connector (Conin), 9 pole, radial, cw Z Bus cover with 3 sealed cable exits A-B5-C 1.5 m cable with M23 connector (Conin), 12 pole, axial B-B5-C 1.5 m cable with M23 connector (Conin), 12 pole, radial

¹ Protection class IP67 not available in combination with LED display for connection with cable (connection code A-B5-C and B-B5-C)

Preferably available versions are printed in bold type.

ACCESSORIES

see chapter "Accessories", starting page 322

Absolute

SUCOnet



Clamping flange

TECHNICAL DATA mechanical

- Compact design
- SUCOnet or Hengstler-G1-Protocol
- Parameterizable: preset, direction, scaling factor, resolution
- PC communication via RS 485 with Hengstler-G1-Protocol



Housing diameter	58 mm
Shaft diameter	6 mm / 10 mm (Solid shaft) 10 mm / 12 mm (Hubshaft)
Flange (Mounting of housing)	Synchro flange, Clamping flange, Tether, Square flange
Protection class shaft input (EN 60529)	IP64 or IP67
Protection class housing (EN 60529)	IP64
Shaft load axial / radial	40 N / 60 N
Max. speed	max. 6000 rpm (continuous), max. 12000 rpm (short term)
Torque	0.5 Ncm
Vibration resistance (DIN EN 60068-2-6)	100 m/s ²
Shock resistance (DIN EN 60068-2-27)	1000 m/s ²
Operating temperature	-10 °C ... +60 °C
Storage temperature	-25 °C ... +85 °C
Material shaft	Stainless Steel
Material housing	Aluminum
Weight	approx. 260 g (ST) / 310 g (MT)
Connection	Cable, axial or radial

TECHNICAL DATA electrical

Supply voltage	DC 10-30 V
Max. current w/o load	200 mA
EMC	EN 61326: class A
Resolution singleturn	10 - 13 Bit
Resolution multiturn	12 Bit
Output code	Binary
Drives	RS485
Linearity	± ½ LSB (± 1 LSB for resolution 13 and 25 Bit)
Profile/ protocol	SUCOnet-K1 or Hengstler-G1
Programmable	Resolution, Direction
Address switch	set via DIP switches
Bus termination resistor	set via DIP switches

Absolute

SUCOnet

DIMENSIONED DRAWINGS

see chapter "Dimensioned drawings AC 58", starting page 185

ORDERING INFORMATION

Type	Resolution	Supply voltage	Flange, Protection, Shaft	Interface	Connection
<input type="checkbox"/>	<input type="text"/>	<input type="checkbox"/>	<input type="checkbox"/>	<input type="checkbox"/>	<input type="checkbox"/>
AC58	0010 10 Bit ST 0012 12 Bit ST 0013 13 Bit ST 1210 12 Bit MT + 10 Bit ST 1212 12 Bit MT + 12 Bit ST 1213 12 Bit MT + 13 Bit ST	E DC 10 - 30 V	S.41 Synchro, IP64, 6 mm K.42 Clamping, IP64, 10 mm K.46 Clamping, IP64, 9.52 mm F.46 Spring tether, IP64, hubs-haft 9.52 mm, mounting with clamping ring front F.42 Spring tether, IP64, hubs-haft 10 mm, mounting with clamping ring front F.47 Spring tether, IP64, hubs-haft 12 mm, mounting with clamping ring front Q.46 Square, IP64, 9.52 mm Q.42 Square, IP64, 10 mm	RS Hengstler-G1-Protocol US SUCOnet	A Cable, axial B Cable, radial

Preferably available versions are printed in bold type.

ORDERING INFORMATION

Selection of cable length

Versions with cable outlet (connection A, B, E or F) are available with various lengths of cable. To order your desired cable length, please add the respective code to the end of your ordering code. Further cable lengths on request.

Code	Cable length
without code	1.5 m
-D0	3 m
-F0	5 m
-K0	10 m
-P0	15 m
-U0	20 m
-V0	25 m

ACCESSORIES

see chapter "Accessories", starting page 322

Absolute

SSI programmable



hubshaft with tether

TECHNICAL DATA
mechanical

- Compact design: 59 mm mounting depth for single or multiturn
- Aids for start up and operation: diagnostic LED, preset key with optical response
- Parameterization: Resolution, code type, direction, output format, warning, alarm
- Parameters can be stored in a non-volatile memory
- Integrated RS232 interface



Housing diameter	58 mm
Shaft diameter	6 mm / 10 mm (Solid shaft) 10 mm / 12 mm (Hub shaft)
Flange (Mounting of housing)	Synchro flange, Clamping flange, Tether, Square flange
Protection class shaft input (EN 60529)	IP64 or IP67
Protection class housing (EN 60529)	IP64 (IP67 optional)
Shaft load axial / radial	40 N / 60 N
Max. speed	max. 10 000 rpm (continuous), max. 12 000 rpm (short term)
Torque	0.5 Ncm
Moment of inertia	ca. 3.8×10^{-6} kgm ²
Vibration resistance (DIN EN 60068-2-6)	100 m/s ² (10 ... 500 Hz)
Shock resistance (DIN EN 60068-2-27)	1000 m/s ² (6 ms)
Operating temperature	-40 °C ... +100 °C
Storage temperature	-40 °C ... +85 °C
Material shaft	Stainless Steel
Material housing	Aluminum
Weight	approx. 260 g (ST) / 310 g (MT)
Connection	Cable, axial or radial M23 connector (Conin), 12 pole, axial or radial

TECHNICAL DATA
electrical

Supply voltage	DC 10-30 V
Max. current w/o load	250 mA (ST / MT)
Resolution singleturn	10 - 17 Bit
Resolution multiturn	12 Bit
Output code	Binary, Gray
Drives	Clock and Data / RS422
Parametrization	Resolution, Code type, Direction, Output format, Warning, Alarm
Control inputs	Direction, Preset 1, Preset 2
Alarm output	Alarm bit
Status LED	Green = ok, red = alarm

Absolute**SSI programmable****RECOMMENDED DATA TRANSFER RATE
bei SSI**

The max. data transfer rate depends on the cable length. For Clock / $\overline{\text{Clock}}$ and Data / $\overline{\text{Data}}$ please use twisted pairs. Use shielded cable.

Cable length	Frequency
< 50 m	< 400 kHz
< 100 m	< 300 kHz
< 200 m	< 200 kHz
< 400 m	< 100 kHz

SYNCHRONOUS-SERIAL TRANSFER (SSI)

A clock brush is applied at the SSI interface, causing the encoder data to be serially clocked out. With each new clock brush (min. interval 30 ms) new data is readout. The following main parameters are programmable:

- Preset: Software-Preset and via input/pushbutton settable presets (can be inactivated)
- Offset: Relative shifting of actual encoder value.
- Scaling: The actual value of the encoder is multiplied with the factor < 1 (direct entry, increments per measuring distance or per revolution).
- Direction of rotation: Can be changed via software or input (can be inactivated)

- Output formats SSI: Tree format or standard format (MSB oriented)
- Output code: The choices are Gray or binary code, integer or two's complement representation. Selection of significant bit between 16 and 24 Bit.

In addition, programming of max. 7 status bits is possible:

- up to 4 warning positions
- overspeed
- encoder standstill
- parity
- encoder error
- direction of rotation

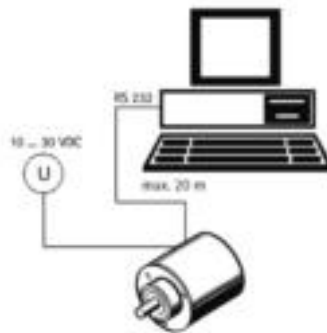
PROGRAMMING with SSI

To program the absolute encoder you require a PC, the software WinSSI and the adapter cable.

The encoder is connected to the power supply and the serial interface of your PC with the adapter cable. Using the menu-assisted programme you can then configure the encoder according to the parameters you require.

OUTPUT FORMAT SSI, MSB oriented, Multiturn

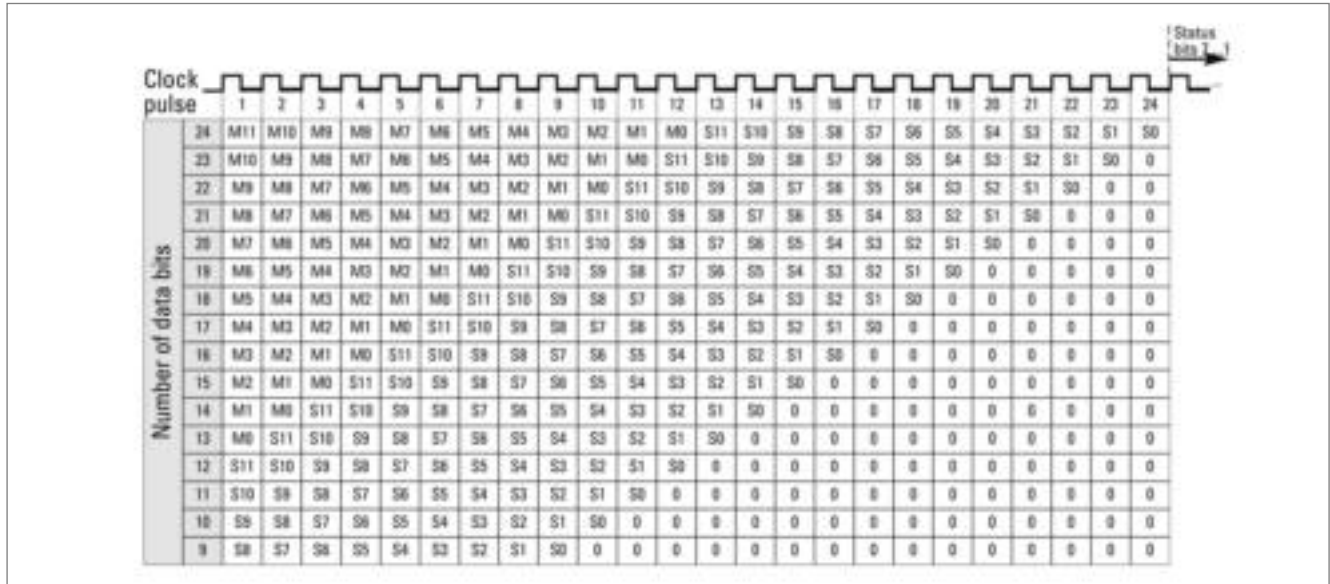

OUTPUT FORMATS SSI, MSB oriented, Multiturn (not scaleable)

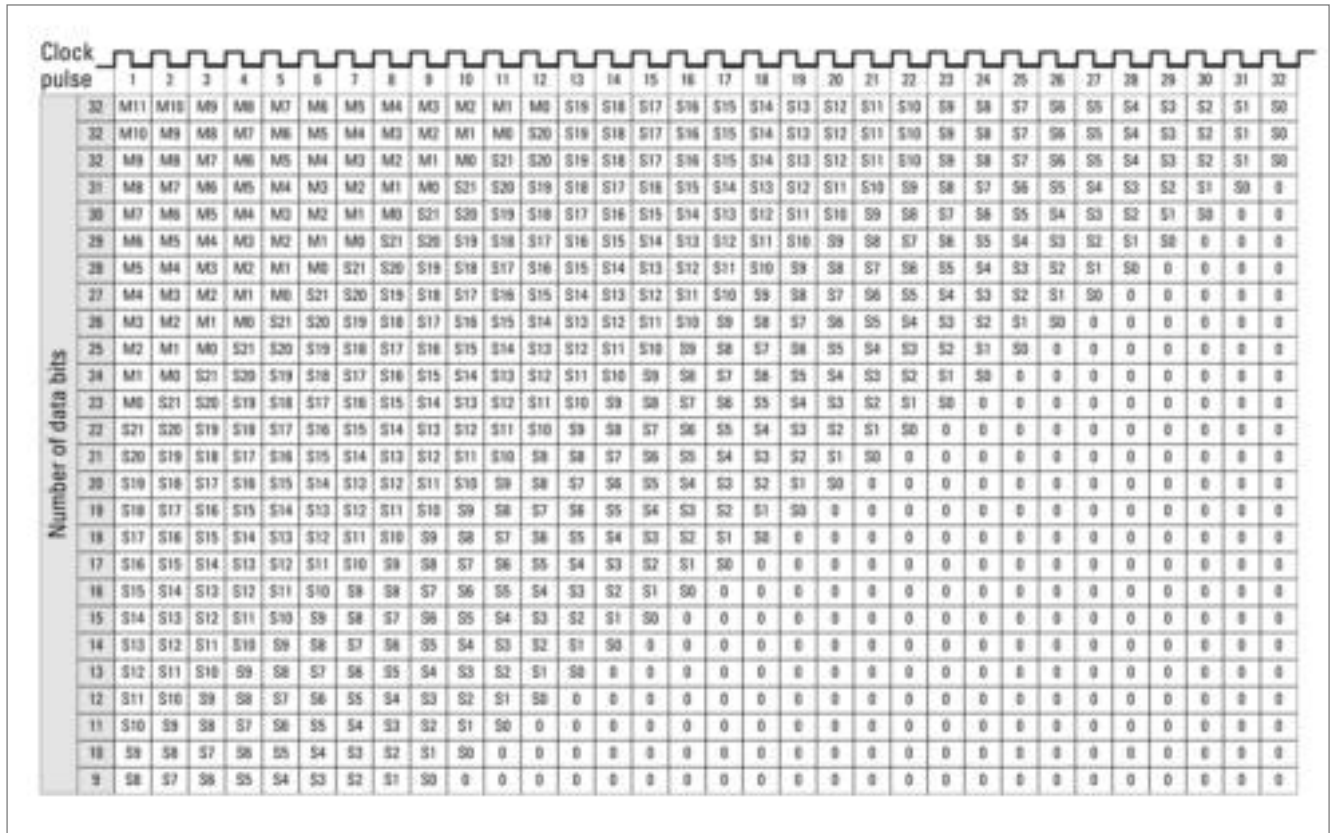

OUTPUT FORMAT SSI, tree format

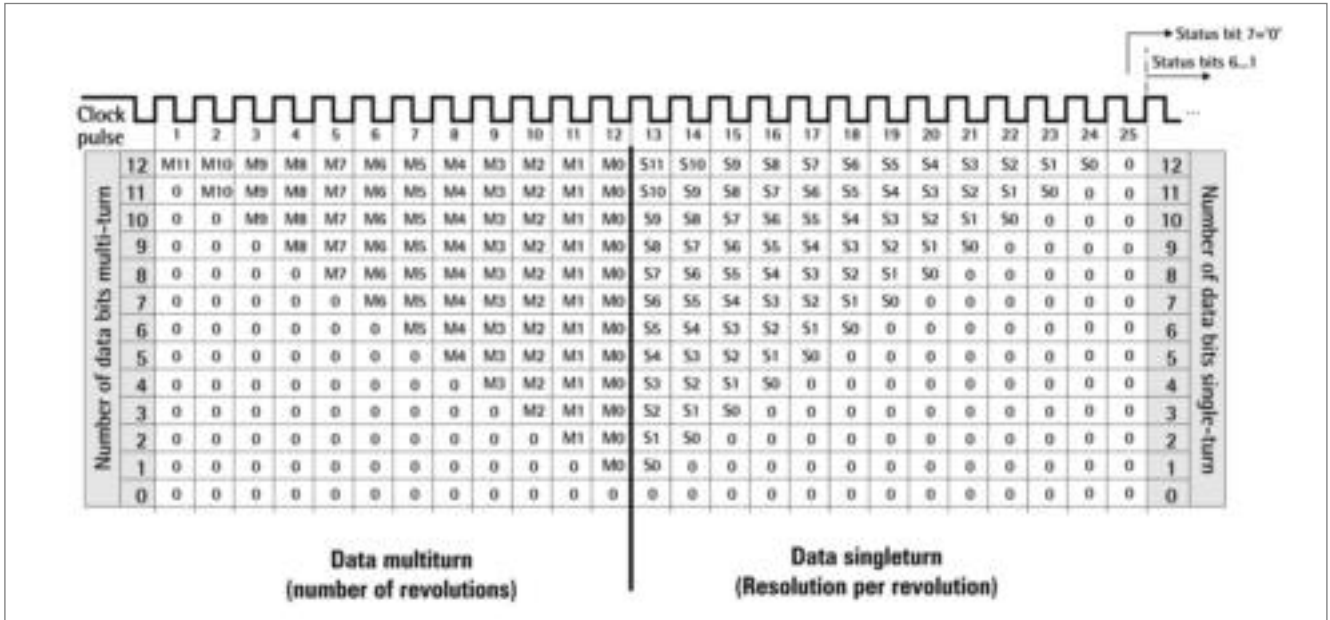

ELECTRICAL CONNECTIONS

M23 connector (Conin), 12 pole / cable

Cable Colour	M23 (Conin) Pin	Signal
green	1	$\overline{\text{Clock}}$
yellow	2	Clock
pink	3	Data
grey	4	$\overline{\text{Data}}$
brown	5	RS 232 TxD
white	6	RS 232 RxD
black	7	0 V-signal output
blue	8	$\overline{\text{Direction}}$
red	9	Preset 1
violet	10	Preset 2
white ¹	11	DC 10 - 30 V
brown ¹	12	0 V (supply voltage)

¹ bigger cross section 0.5 mm ²

DIMENSIONED DRAWINGS

see chapter "Dimensioned drawings AC 58", starting page 185

ORDERING INFORMATION

Type	Resolution	Supply voltage	Flange, Protection, Shaft ^{1,2}	Interface	Connection
<input type="checkbox"/>	<input type="checkbox"/>	<input type="checkbox"/>	<input type="checkbox"/>	<input type="checkbox"/>	<input type="checkbox"/>
AC58	0010 10 Bit ST 0012 12 Bit ST 0013 13 Bit ST 0014 14 Bit ST 0017 17 Bit ST 1212 12 Bit MT + 12 Bit ST 1213 12 Bit MT + 13 Bit ST 1214 12 Bit MT + 14 Bit ST 1217 12 Bit MT + 17 Bit ST higher resolution on request	E DC 10 - 30 V	S.41 Synchro, IP64, 6 mm S.71 Synchro, IP67, 6 mm K.42 Clamping, IP64, 10 mm K.46 Clamping, IP64, 9.52 mm K.72 Clamping, IP67, 10 mm K.76 Clamping, IP67, 9.52 mm F.46 Spring tether, IP64, hubs-haft 9.52 mm, mounting with clamping ring front F.42 Spring tether, IP64, hubs-haft 10 mm, mounting with clamping ring front F.47 Spring tether, IP64, hubs-haft 12 mm, mounting with clamping ring front Q.46 Square, IP64, 9.52 mm Q.42 Square, IP64, 10 mm Q.76 Square, IP67, 9.52 mm Q.72 Square, IP67, 10 mm	SP SSI programmable	G M23 connector (Conin), 12 pole, axial, ccw H M23 connector (Conin), 12 pole, radial, ccw

¹ Protection class IP67 not available in combination with preset key and LED display

² IP67 on cover with connector only if IP67 mating connector mounted properly.

Preferably available versions are printed in bold type.

ACCESSORIES

see chapter "Accessories", starting page 322

DIMENSIONED DRAWINGS

Synchro flange "S"

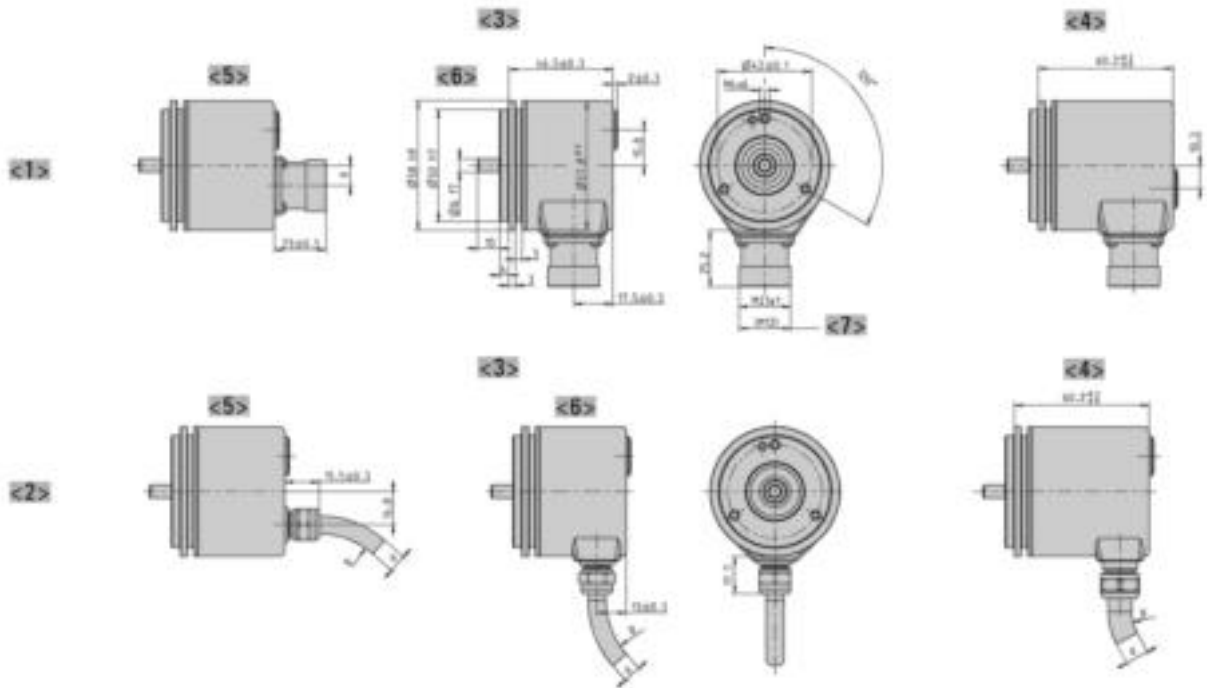

- <1> Connection M23 (Conin)
- <2> Connection cable
- <3> Interface: BiSS, SSI, ST-Parallel
- <4> Interface: MT-Parallel (only with cable), Fieldbus, SSI-P
- <5> axial
- <6> radial
- <7> Value in brackets alternative at SSI

Cable bending radius R for flexible installation $\geq 15 \times$ cable diameter
 Cable bending radius R for fixed installation $\geq 7.5 \times$ cable diameter
 Cable \varnothing d BiSS/SSI/SSI-P: $7,1^{+1,2}$
 Cable \varnothing d ST-P: $7,8^{+0,9}$
 Cable \varnothing d MT-P: $9,3^{+1,3}$
 Cable \varnothing d Fieldbus: $7,1^{+1,2}$

Dimensions in mm

DIMENSIONED DRAWINGS (continued)

Clamping flange "K"

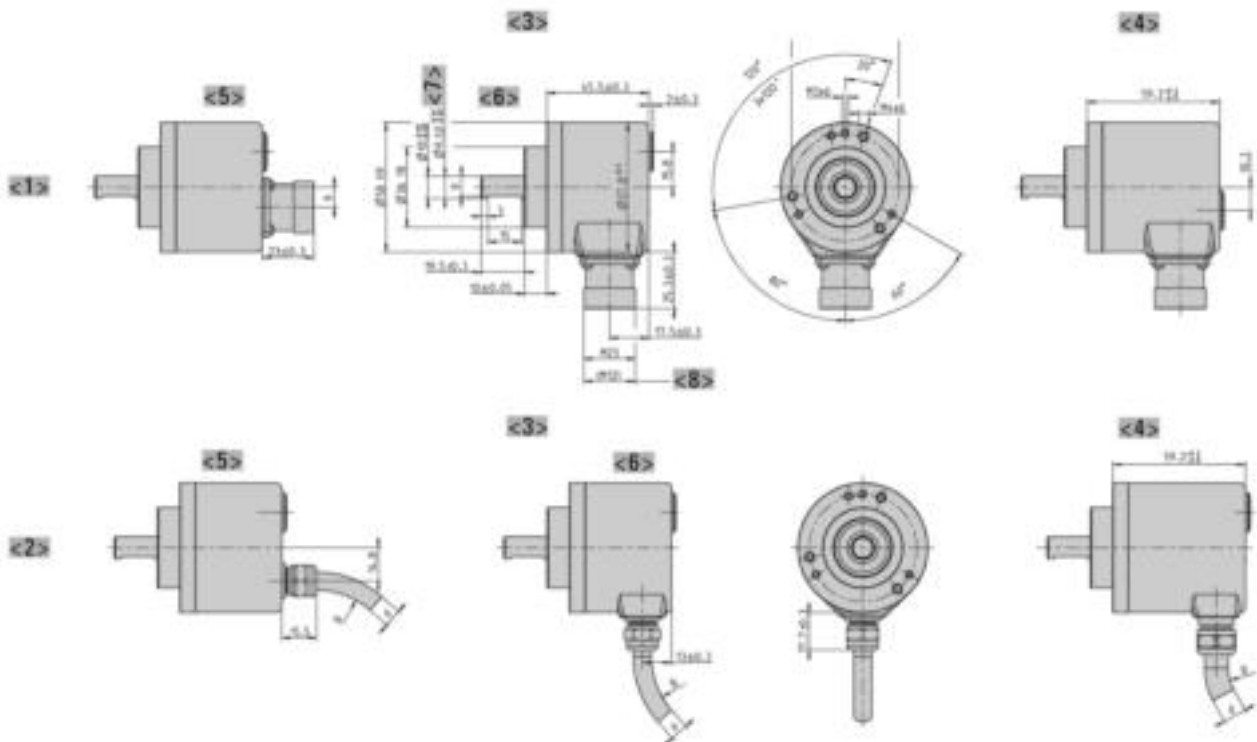

- <1> Connection M23 (Conin)
- <2> Connection cable
- <3> Interface: BiSS, SSI, ST-Parallel
- <4> Interface: MT-Parallel (only with cable), Fieldbus, SSI-P
- <5> axial
- <6> radial
- <7> alternative

- <8> Value in brackets alternative at SSI
- Cable bending radius R for flexible installation $\geq 15 \times$ cable diameter
- Cable bending radius R for fixed installation $\geq 7.5 \times$ cable diameter
- Cable \varnothing d BiSS/SSI/SSI-P: $7,1^{+1,2}$
- Cable \varnothing d ST-P: $7,8^{+0,9}$
- Cable \varnothing d MT-P: $9,3^{+1,3}$
- Cable \varnothing d Fieldbus: $7,1^{+1,2}$

Dimensions in mm

DIMENSIONED DRAWINGS (continued)

Hollow shaft "F"

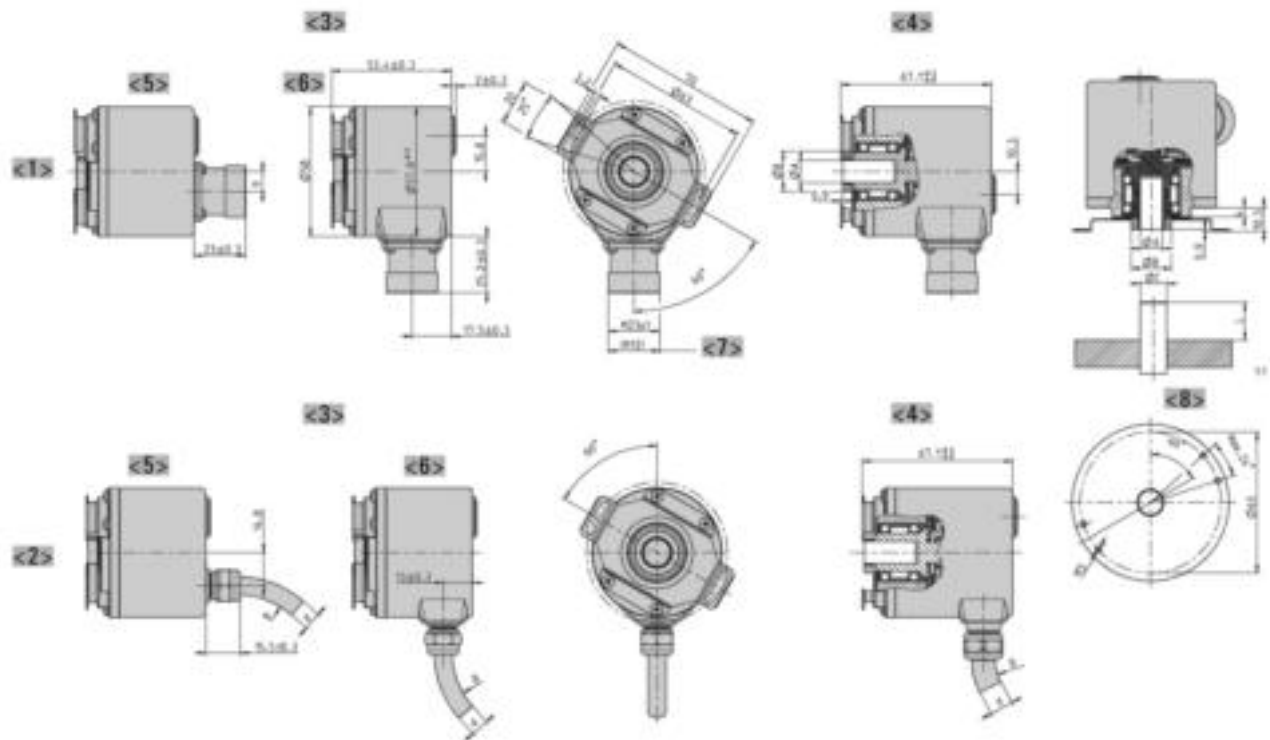

	Dim.				Unit
Hollow shaft Ø A	10 ^{+0.012}	12 ^{+0.012}	9,52 ^{+0.012}	12,7 ^{+0.012}	mm
Connecting shaft Ø C	10 _{g7}	12 _{g7}	9,52 _{g7}	12,7 _{g7}	mm
Clamping ring Ø B	18	20	18	22	mm
L _{min}	15	18	15	18	mm
L _{max}	20	20	20	20	mm
Shaft code	"2"	"7"	"6"	"E"	
L = Inside length of connection shaft					

- <1> Connection M23 (Conin)
 - <2> Connection cable
 - <3> Interface: BiSS, SSI, ST-Parallel
 - <4> Interface: MT-Parallel (only with cable), Fieldbus, SSI-P
 - <5> axial
 - <6> radial
 - <7> Value in brackets alternative at SSI
 - <8> Customer side
- Cable bending radius R for flexible installation ≥ 15 x cable diameter
 Cable bending radius R for fixed installation ≥ 7.5 x cable diameter
 Cable Ø d BiSS/SSI/SSI-P: 7,1^{+1,2}
 Cable Ø d ST-P: 7,8^{+0,9}
 Cable Ø d MT-P: 9,3^{+1,3}
 Cable Ø d Fieldbus: 7,1^{+1,2}

Dimensions in mm

DIMENSIONED DRAWINGS (continued)

Square flange "Q"

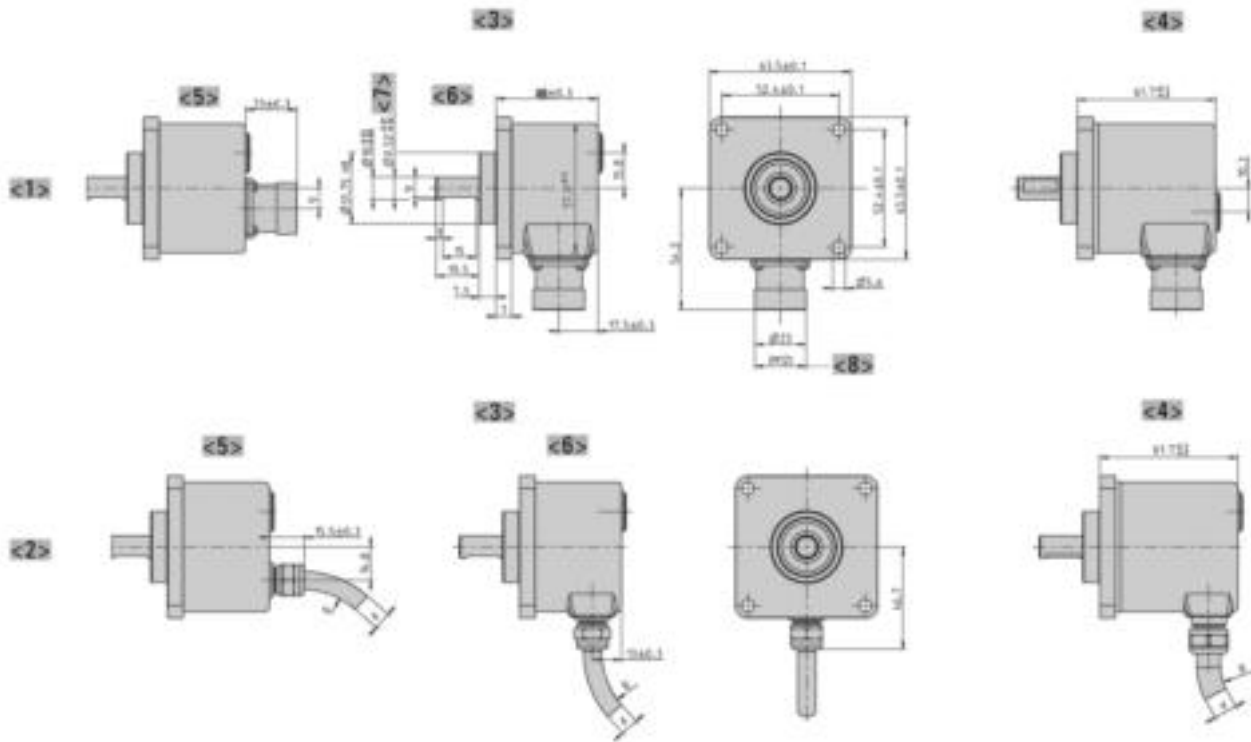

- <1> Connection M23 (Conin)
- <2> Connection cable
- <3> Interface: BiSS, SSI, ST-Parallel
- <4> Interface: MT-Parallel (only with cable), Fieldbus, SSI-P
- <5> axial
- <6> radial
- <7> alternative

- <8> Value in brackets alternative at SSI
- Cable bending radius R for flexible installation $\geq 15 \times$ cable diameter
- Cable bending radius R for fixed installation $\geq 7.5 \times$ cable diameter
- Cable \varnothing d BiSS/SSI/SSI-P: $7,1^{+1,2}$
- Cable \varnothing d ST-P: $7,8^{+0,9}$
- Cable \varnothing d MT-P: $9,3^{+1,3}$
- Cable \varnothing d Fieldbus: $7,1^{+1,2}$

Dimensions in mm

DIMENSIONED DRAWINGS (continued)

Bus covers

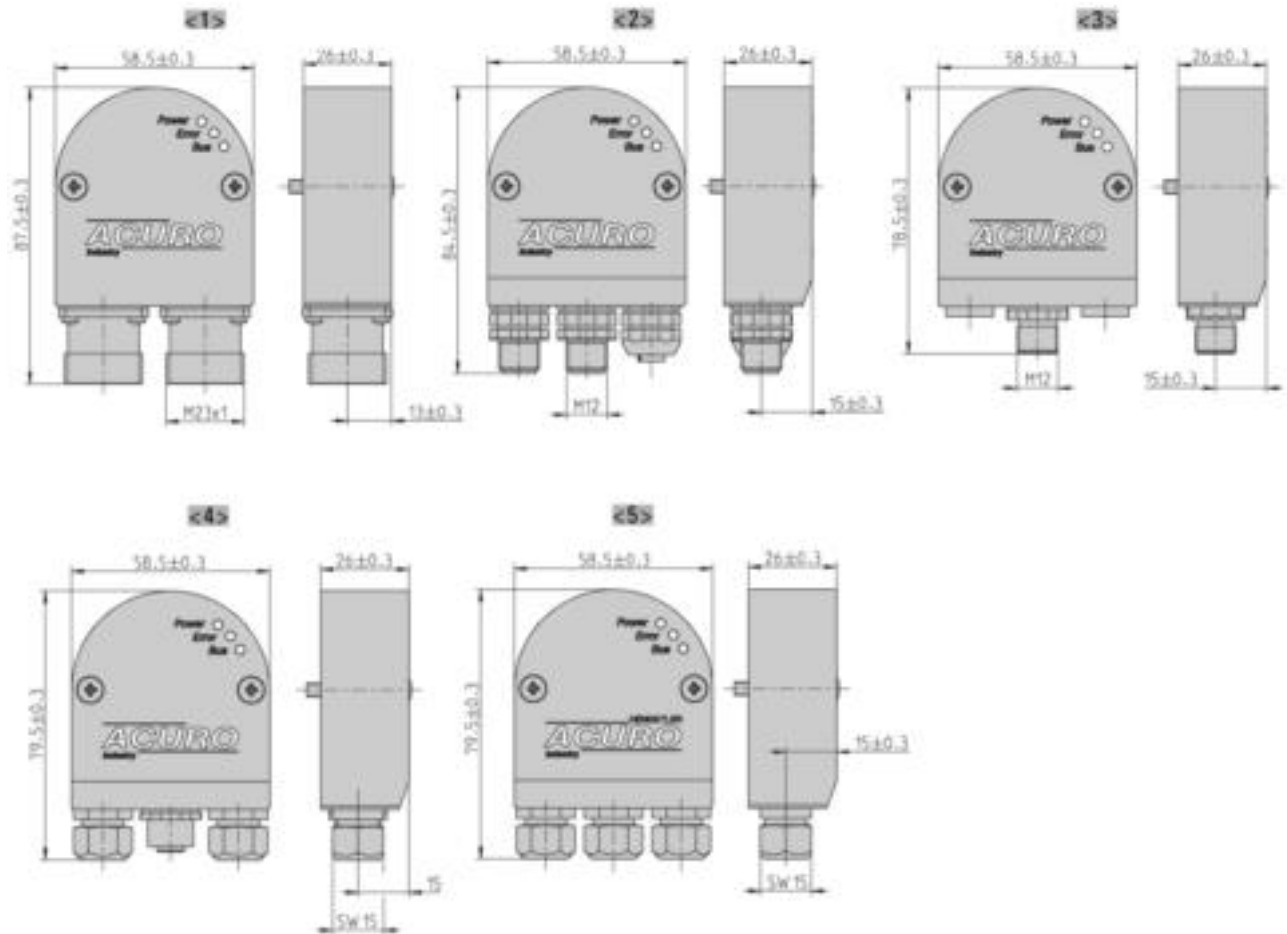

- <1> Connection "I"
- <2> Connection "R"
- <3> Connection "S"

- <4> Connection "T"
- <5> Connection "Z"

Dimensions in mm

DIMENSIONED DRAWINGS (continued)

Synchro flange "S"

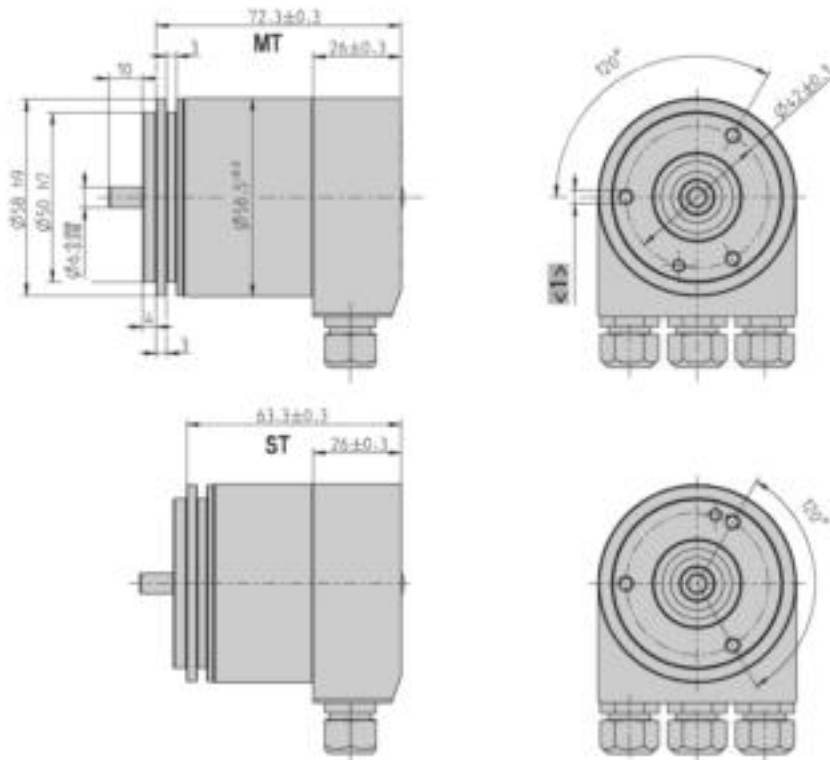

<1> 3xM4 (6 deep)

Dimensions in mm

DIMENSIONED DRAWINGS (continued)

Clamping flange "K"

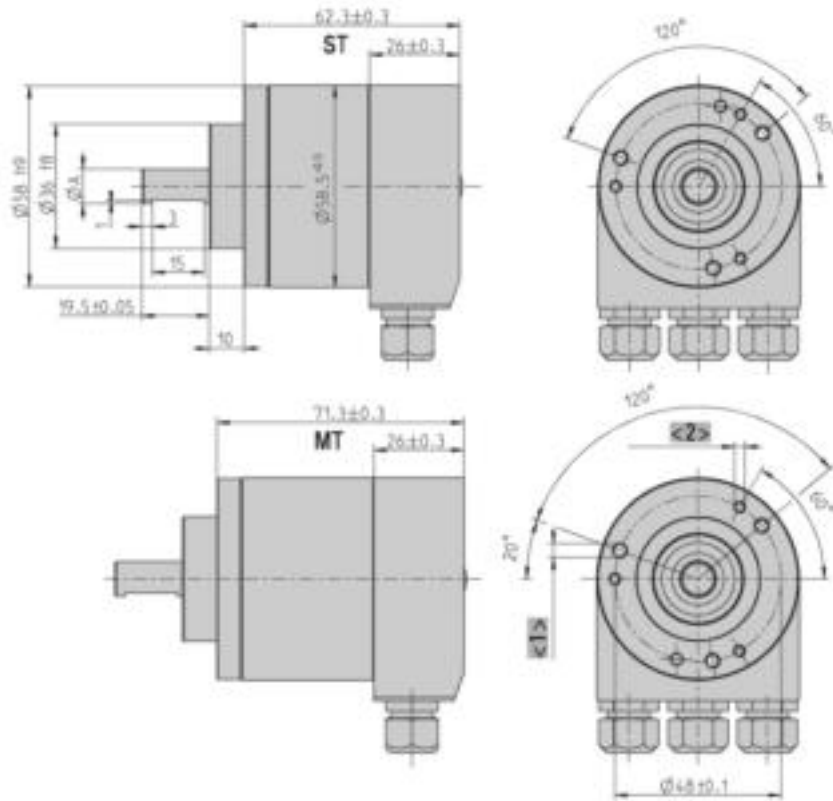

	Dim.		Unit
Shaft Ø A	10 ^{-0.01/-0.02}	9.52 ^{-0.01/-0.02}	mm
Shaft code	"2"	"6"	

- <1> 3xM4 (6 deep)
- <2> 3xM3 (6 deep)

Dimensions in mm

DIMENSIONED DRAWINGS (continued)

Hollow shaft "F"

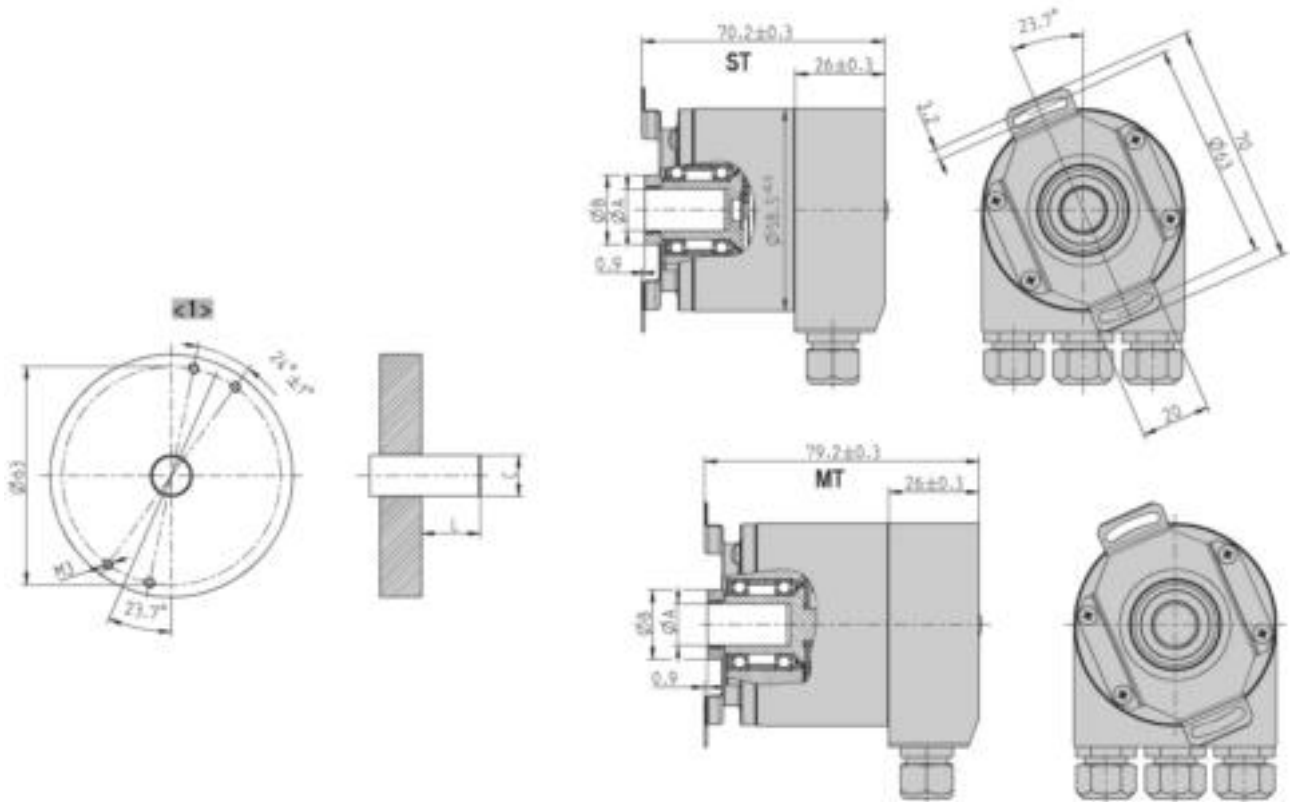

	Dim.				Unit
Hollow shaft Ø A	10 ^{+0.012}	12 ^{+0.012}	9,52 ^{+0.012}	12,7 ^{+0.012}	mm
Connecting shaft Ø C	10 _{g7}	12 _{g7}	9,52 _{g7}	12,7 _{g7}	mm
Clamping ring Ø B	18	20	18	22	mm
L _{min}	15	18	15	18	mm
L _{max}	20	20	20	20	mm
Shaft code	"2"	"7"	"6"	"E"	
L = Inside length of connection shaft					

<1> Customer side

Dimensions in mm

DIMENSIONED DRAWINGS (continued)

Square flange "Q"

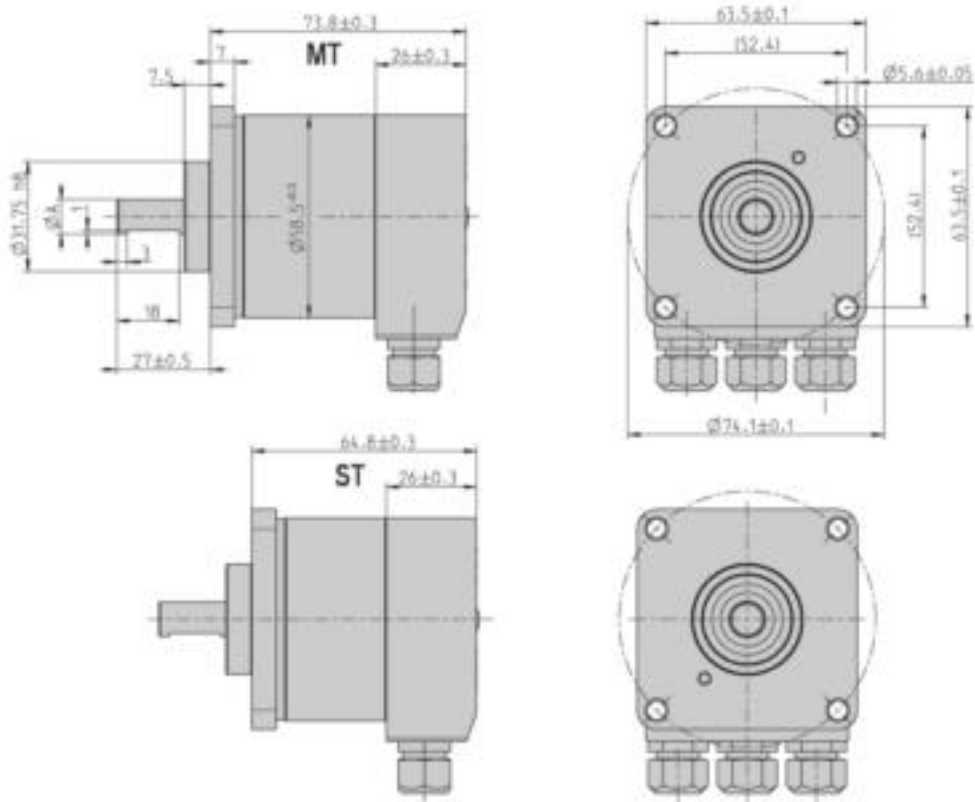

	Dim.		Unit
Shaft Ø A	10 ^{-0.01/-0.02}	9.52 ^{-0.01/-0.02}	mm
Shaft code	"2"	"6"	

Dimensions in mm

Absolute

BiSS / SSI



- Same electrical performance as ACURO industry
- Robust bearings for long life
- Hollow shaft up to 50 mm
- Absolute singleturn
- Revolution 11-17 Bit
- BiSS or SSI interface
- Optional: Sine-Cosine 4096 increments
- DC 5 or 10 - 30 V
- Integrated diagnostic system



GENERAL INFORMATION

HENGSTLER OPTOASIC Technology

The central Element of the ACURO AC110 is the latest Hengstler OptoASIC technology, which offers the following key benefits.

- Outstanding reliability by reduced number of components and integrated diagnostics systems
- Aging compensation by integrated LED light regulation
- Integrated monitoring of pollution, disk damage, LED lifetime and temperature

The ACURO AC110 is ideally suited for applications like:

- Gearless drive
- Gearless elevators
- Industrial Machinery

TECHNICAL DATA mechanical

Housing diameter	110 mm
Shaft diameter	50 mm (Hub shaft)
Mounting of shaft	Keyway, Rear clamping ring
Protection class shaft input (EN 60529)	IP50 or IP64
Protection class housing (EN 60529)	IP40 or IP64
Axial endplay of mounting shaft (hubshaft)	± 0.5 mm
Radial runout of mating shaft (hubshaft)	± 0.05 mm
Max. speed	IP40: max. 3600 rpm IP50: max. 2000 rpm IP64: max. 1500 rpm
Torque	15 Ncm
Vibration resistance (DIN EN 60068-2-6)	100 m/s ² (10 ... 500 Hz)
Shock resistance (DIN EN 60068-2-27)	1000 m/s ² (6 ms)
Operating temperature	-20 °C ... +70 °C
Storage temperature	-50 °C ... +80 °C
Material shaft	Stainless Steel / Aluminum, ceramic coated
Material housing	Aluminum
Weight	approx. 1000 g

Absolute

BiSS / SSI

TECHNICAL DATA
mechanical (continued)

Connection	Cable, radial Cable 1.5 m with M23 connector (Conin), 12 pole, axial or radial
------------	---

TECHNICAL DATA
electrical

Supply voltage	-5%/ 10% DC 5 V DC 10-30 V
Max. current w/o load	120 mA (ST)
Resolution singleturn	10 - 17 Bit
Output code	Binary, Gray
Drives	Clock and Data / RS422
Incremental signals optional	Sinus-Cosinus 1 Vpp
Number of pulses	4096
3dB limiting frequency	500 kHz
Alarm output	Alarm bit (SSI Option), warning and alarm bit (BiSS)

RECOMMENDED DATA TRANSFER RATE
bei SSI

The max. data transfer rate depends on the cable length. For Clock / $\overline{\text{Clock}}$ and Data / $\overline{\text{Data}}$ please use twisted pairs. Use shielded cable.

Cable length	Frequency
< 50 m	< 400 kHz
< 100 m	< 300 kHz
< 200 m	< 200 kHz
< 400 m	< 100 kHz

ELECTRICAL CONNECTIONS
**Cable / Cable with M23 connector (Conin),
 12 pole**

Colour cable	Cable connector	Signal
brown ⁴	1	0 V (supply voltage)
pink	2	Data
yellow	3	Clock
	4	N.C.
blue	5	$\overline{\text{Direction}}$ ¹
	6	N.C.
	7	N.C.
white ⁴	8	DC 5 V ³ / DC 10 - 30 V
	9	N.C.
grey	10	$\overline{\text{Data}}$
green	11	$\overline{\text{Clock}}$
black	12	0 V-signal output ²
Screen		Shielded with housing

¹ Direction: + UB or unconnected = ascending code values with rotation cw

0 V = descending code values with rotation cw

² Connected with 0 V in the encoder. Use this output to lay Direction on logical "0" if required.

³ Notice: when supply voltage = DC 5V \Rightarrow max. cable length 10 m

⁴ Use only thin wires 0.14 mm ²

DIMENSIONED DRAWINGS

Keyway

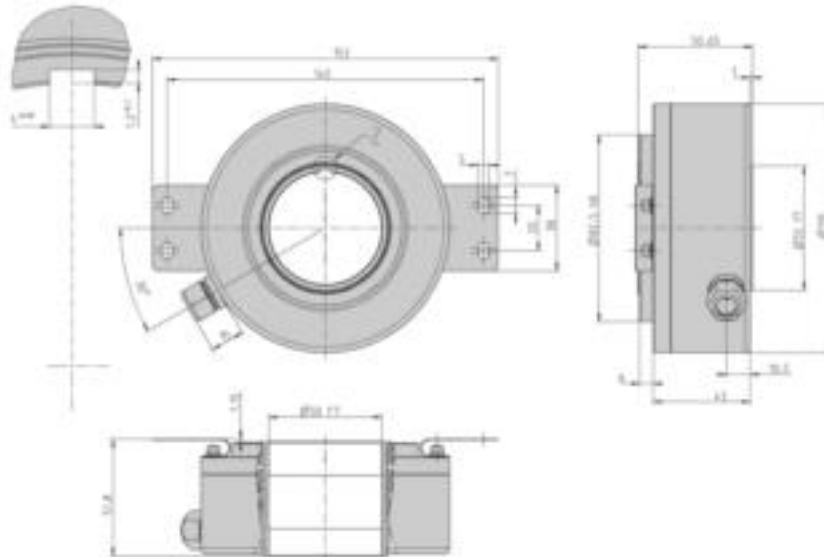

Dimensions in mm

Clamping ring

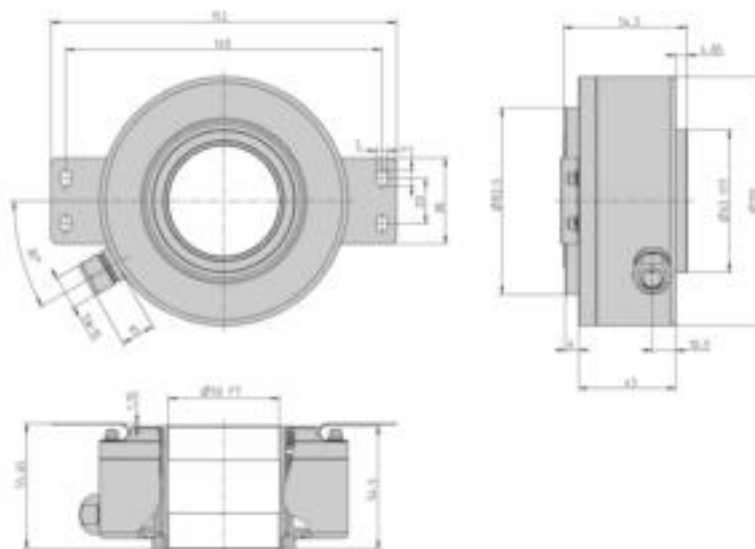

Dimensions in mm

ORDERING INFORMATION

Type	Resolution ¹	Supply voltage ²	Shaft	Protection	Spring tether	Interface	Connection
<input type="checkbox"/>	<input type="checkbox"/>	<input type="checkbox"/>	<input type="checkbox"/>	<input type="checkbox"/>	<input type="checkbox"/>	<input type="checkbox"/>	<input type="checkbox"/>
AC110	0010 10 Bit ST 0012 12 Bit ST 0013 13 Bit ST 0014 14 Bit ST 0017 17 Bit ST	A DC 5 V E DC 10 - 30 V	K50 Keyway (4x1,2) / 50 mm H50 Clamping ring / 50 mm	0 IP40 1 IP50 4 IP64	0 Without tether B With tether	BI BiSS SB SSI binary SG SSI Gray	B Cable, radial B-D 1.5 m cable with M23 connector (Conin), 12 pole

¹ When resolution > 14 Bit: max. clock frequency 178 kHz

² Max. cable length for DC 5 V: 10 m

ORDERING INFORMATION

Selection of cable length

Versions with cable outlet (connection A, B, E or F) are available with various lengths of cable. To order your desired cable length, please add the respective code to the end of your ordering code. Further cable lengths on request.

Code	Cable length
without code	1.5 m
-D0	3 m
-F0	5 m
-K0	10 m
-P0	15 m
-U0	20 m
-V0	25 m

ACCESSORIES

see chapter "Accessories", starting page 322