

Pneumatics

There are applications for these components in all areas of automation where pneumatic actuators such as cylinders or grippers are used, particularly in environments where no electric signals can be used because of the danger of explosion. Further examples of uses are door control with track vehicles or controlling mixing in dosage equipment.

Using the building blocks offered by Hengstler's pneumatic range, you can construct your own control systems which are only pneumatically driven.

Typical applications:

- Quantity counting
- Stroke counting
- Order and daily production value recording
- Service life and maintenance counter
- Packaging unit control
- Time control with manual intervention
- Fully automatic time control
- Clock generator
- Purely pneumatic cylinder limit switches
- Door opening times
- Process step control
- Dosage rate control

Pneumatic Totalizing, Preset and Preset Time Counters



Type	Type 495, Integrated	Type 495 for surface-mounting	Type 497	Type 497
Features	<ul style="list-style-type: none"> ■ Integrated totalizing counter ■ 6-digit or 8-digit display ■ Manual reset, pneumatic reset, or without reset function ■ Hose coupler or rapid-fit connector ■ Easy to install ■ Maintenance-free operation 	<ul style="list-style-type: none"> ■ Surface-mount totalizing counter ■ 6-digit display ■ Manual or pneumatic reset ■ Hose coupler or rapid-fit connector ■ Easy to mount ■ Maintenance-free operation 	<ul style="list-style-type: none"> ■ Integrated preset counter ■ Adding or subtracting ■ 3-digit or 5-digit display ■ Integrated pneumatic reset ■ Convenient button setting ■ Adding; with continuously visible preset 	<ul style="list-style-type: none"> ■ Integrated preset time counter ■ 3-digit or 5-digit display ■ Integrated pneumatic reset ■ Convenient button setting ■ Hose coupler or rapid-fit connector ■ Continuously visible preset
Technical Data				
Dimensions (mm) (Width x Height x Depth)	60 x 51 x 65	53 x 100 x 26	60 x 75 x 62	60 x 75 x 122
Front panel cutout (mm)	52 x 26		52 x 52	52 x 52
Display	8-digit 4 mm 6-digit 4 mm	6-digit, 4 mm	3-digit 4 mm 5-digit 4 mm	3-digit 4 mm 5-digit 4 mm
Operating pressure	2-8 bar	2-8 bar	2-8 bar	2-8 bar
Air	Filtered (< 40 µm) oil-free	Filtered (< 40 µm) oil-free	Filtered (< 40 µm) oil-free	Filtered (< 40 µm) oil-free
Inputs				
Count input	Adding	Adding	Adding, subtracting; depending on version	Adding
Frequency/Time format	25 Hz / 8 ms	25 Hz / 8 ms	20 Hz / 8 ms	Seconds, minutes, depending on version
Options	Hose coupler M5; or rapid-fit connector	Hose coupler M5, or rapid-fit connector	With automatic reset; hose coupler M5, or rapid-fit connector	With automatic reset; hose coupler M5, or rapid-fit connector
Reset input	Manual, pneumatic, or without reset function	Manual or pneumatic	Manual, pneumatic or automatic	Manual, pneumatic or automatic
Output			On reaching the preset/zero value	On reaching the preset value
Page	224	226	229	234

Pneumatic Timers, Proximity Switches, Signal Indicators



Type	Type 499 Timer	Reset Module	Proximity Switch	Signal Indicator
Features	<ul style="list-style-type: none"> ■ Integrated timer; optional for DIN-rail mounting ■ DIN-dimensions ■ Small mounting dimensions ■ No continuous air supply required ■ Stationary preset value ■ 0.2 to 300 seconds 	<ul style="list-style-type: none"> ■ Integrated reset module for timers ■ Enables automatic timer sequences ■ DIN dimensions ■ Small mounting dimensions ■ Stationary preset ■ Output signal adjustable from 0.2 - 2 seconds 	<ul style="list-style-type: none"> ■ Non-contact actuation ■ Small mounting dimensions ■ Can be actuated by magnetic field and iron (Fe) ■ No continuous air consumption 	<ul style="list-style-type: none"> ■ Signals the operating status of pneumatic hose connections ■ Easy to mount ■ Connections/fittings for 2 or 3 mm hoses (internal diameter) ■ Operating pressure 2-8 bar ■ No air consumption
Technical Data				
Dimensions (mm) (Width x Height x Depth)	24 x 48 x 60	24 x 48 x 60	18.2 x 40.3 x 19.6	30 x D9
Front panel cutout (mm)	22.2 x 45	22.2 x 45		
Display	Digit roll	Digit roll		Yellow signal indication (while being pressurized)
Operating pressure	2-6 bar	2-6 bar	2-6 bar	2-8 bar
Air	Filtered (<40 µm) oil-free	Filtered (< 40 µm) Non-oiled; light oil mist is permissible	Filtered (< 40 µm) Non-oiled; light oil mist is permissible	Filtered (< 40 µm) Non-oiled; light oil mist is permissible
Inputs				
Start input	Timer is started as soon as input is pressurized	Time starts elapsing as soon as the input is pressurized	Magnetic field and Fe actuation	Upon application of pressure
Time range	0.2-3 s; 2-30 s, 20-300 s; depending on version	0.2 - 2 s	Actuating distance Fe: approx. 2 mm	As long as the hose is pressurized
Options	Hose coupler M5 or rapid-fit connector; DIN-rail mounting	Hose coupler M5, or rapid-fit connector	Strap retainer attachment	Fittings for hose diameters 2 or 3 mm (internal diameter)
Reset	By interrupting the air intake			
Output				
	After the set time has elapsed, input 1 is connected to output 2	Interrupts the output for approx. 300 ms after the set time value has elapsed	Upon actuation by magnetic field or Fe	
Page	236	238	240	241

Pneumatic Totalizing Counters

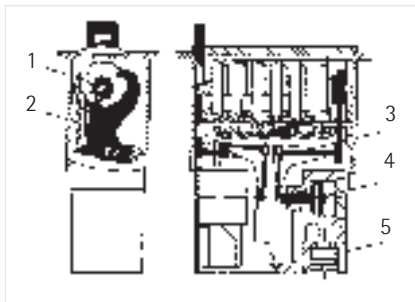

- 1 Figure wheel
- 2 Rocker
- 3 Blade
- 4 Piston of the actuator system
- 5 Connection

- RT Button reset
RP Pneumatic reset

FEATURES

FUNCTION

RESETTING

AMBIENT CONDITIONS

MAINTENANCE

USE OF COUNTERS

MODIFICATIONS

The pneumatic totalizing counter consists of a pneumatic actuator system and a mechanical figure wheel system. The counter is actuated by pneumatic pulses generated by switches, sensors, etc.

Compressed air pulses exert pressure on the piston of the actuator system via the connection (hose coupler or rapid-fit coupling). The blade, loosely connected to the rocker, is actuated by the tappet. With each pulse, the rocker moves the ones drum by one half of a figure (one half-increment) and simultaneously tensions a spring which moves the drum a further half-increment as the pressure drops.

External resetting of totalizing, preset and differential counters is possible by means of a reset module integrated in the counter.

If the counters are used in extremely soiled surroundings, we highly recommend operating the counters in the specially designed protective covers.

The products shown in this catalogue are maintenance-free.

Versatile service-pressure counters in integration mounting and surface-mount construction are designed to count a wide range of processes which operate with pneumatic pulses; the counters can be reset manually or pneumatically (external reset) before each new counting procedure.

The counters are used as event, piece and batch counters, as integrators, for program step display and more.

All dimensions, technical data and other specifications represent the standard of production and knowledge attained when the material was printed. The functional features of the devices refer to the condition of the devices when new and under normal operating conditions (+ 15 to + 25 °C, non-aggressive atmosphere and neutral operating media). The devices must be protected against freezing at temperatures under + 5 °C.

Pneumatic Totalizing Counters

CONNECTION OPTIONS

Totalizing counters (integration mounting and surface-mount versions) are available with either R 1/8", M5 or rapid-fit couplings.

The corresponding type of connection is defined by the ordering code of the counter and need not be mentioned additionally when ordering.

Commercially available fixtures can be used for R 1/8" and M 5 connections.

Rapid-fit couplings are mounted in the counters. We recommend the use of Rilsan hoses (tubes) with 4 mm outside diameter.

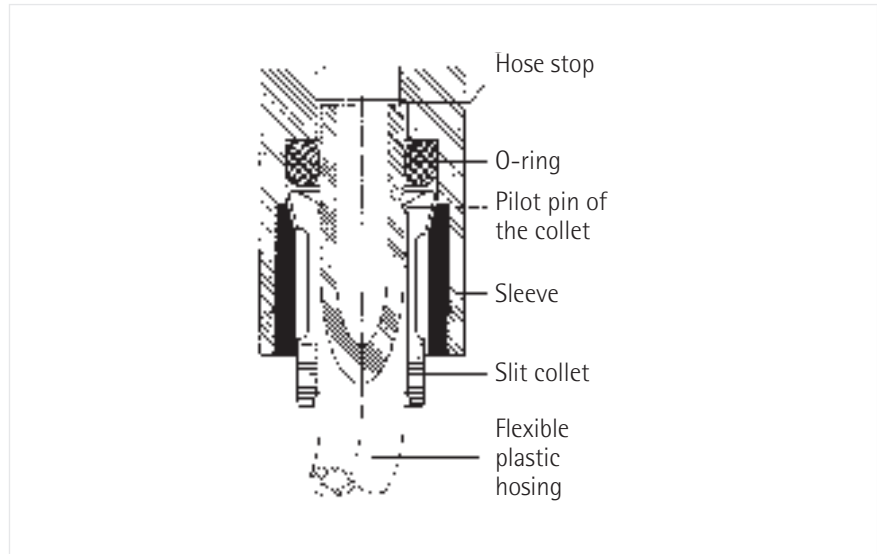

All hoses are simply inserted into the rapid-fit couplings. Ensure that the hose is inserted far enough to allow the O-ring to seal properly. The hose is released by pressing (e.g. using a screw driver) the guide ring and pulling the hose at the same time.

Advantages of the rapid-fit couplings

Hoses and tubes of 2.7 mm x 4 mm are simply inserted. This ensures quick installation and minimum set-up costs.

Type 495

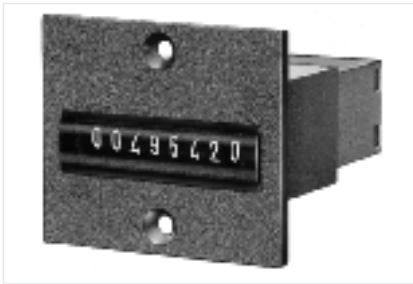

TECHNICAL DATA

Pneumatic Totalizing Counter

- 6 or 8-digit display
- Manual/pneumatic reset or without reset
- Simple installation
- Screw connection hose coupler or rapid-fit connector
- Maintenance-free operation

Display	6 or 8-digit, depending on version
Digit height	4 mm
Service pressure	2 . . . 8 bar
Air quality	non-oily
Filter pore width	< 40 µm
Operating temperature	- 15 . . . + 60 °C
Storage temperature	- 40 . . . + 60 °C
Connection	hose coupler M5 or rapid-fit connector, depending on version
Mounting position	any
Vibrostability	50 m/s ² acc. to IEC 068 2-6
Shock stability	400 m/s ² acc. to IEC 068 2-27
Maintenance-free operation	counting 30 x 10 ⁶ pulses, reset 1.5 x 10 ⁶ pulses
Weight	approx. 60 g
Count input	adding
Pulse length min..	8 ms
Counting frequency max.	25 Hz
Pulse duty factor	see glossary "counting frequency"
Reset	depending on version
	6-digit counter
	- manual with button
	- pneumatic, min. pulse length 180 ms
	ATTENTION: minimum time period between last count pulse and pneumatic reset is 50 ms
	8-digit counter
	- without reset

DIMENSIONED DRAWINGS

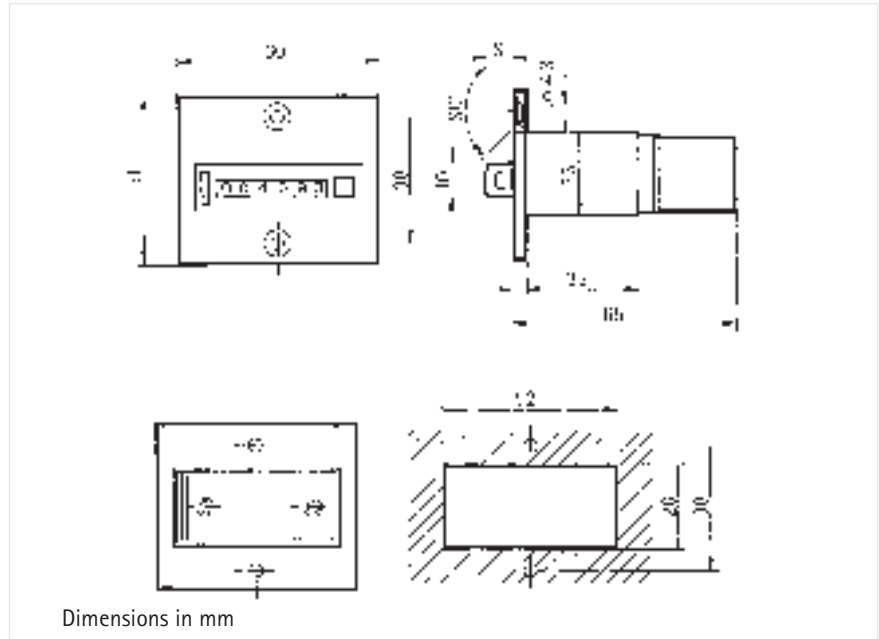

Dimensions in mm

ORDER INFORMATION

Counter

Accessories

Connection	6-digit	8-digit
Hose coupler M5	0 495 464	-
Rapid-fit connector	0 495 465	0 495 422
Protective cover IP 55	with knob	1 405 611
	with lock	1 405 612
Fittings for hose M5 x 1	3 641 733	
Connection kit M5/R 1/8"	1 495 089*	

* on request

Type 495



TECHNICAL DATA

Pneumatic Totalizing Counter for Surface Mounting

- 6-digit display
- Manual/pneumatic reset or without reset
- Simple installation
- Screw connection hose coupler or rapid-fit connector
- Maintenance-free operation

Display	6-digit
Digit height	4 mm
Service pressure	2 ... 8 bar
Air quality	non-oily
Filter pore width	< 40 µm
Operating temperature	- 15 ... + 60 °C
Storage temperature	- 40 ... + 60 °C
Connection	hose coupler M5 or rapid-fit connector, depending on version
Mounting position	any
Vibrostability	50 m/s ² acc. to IEC 068 2-6
Shock stability	400 m/s ² acc. to IEC 068 2-27
Maintenance-free operation	counting 30 x 10 ⁶ pulses, reset 1.5 x 10 ⁶ pulses
Weight	approx. 60 g
Count input	adding
Pulse length min.	8 ms
Counting frequency max.	25 Hz
Pulse duty factor	see glossary "counting frequency"
Reset	depending on version
	- manual with button
	- pneumatic, min. pulse length 180 ms
	ATTENTION: minimum time period between last count pulse and pneumatic reset is 50 ms
	- without reset

DIMENSIONED DRAWING

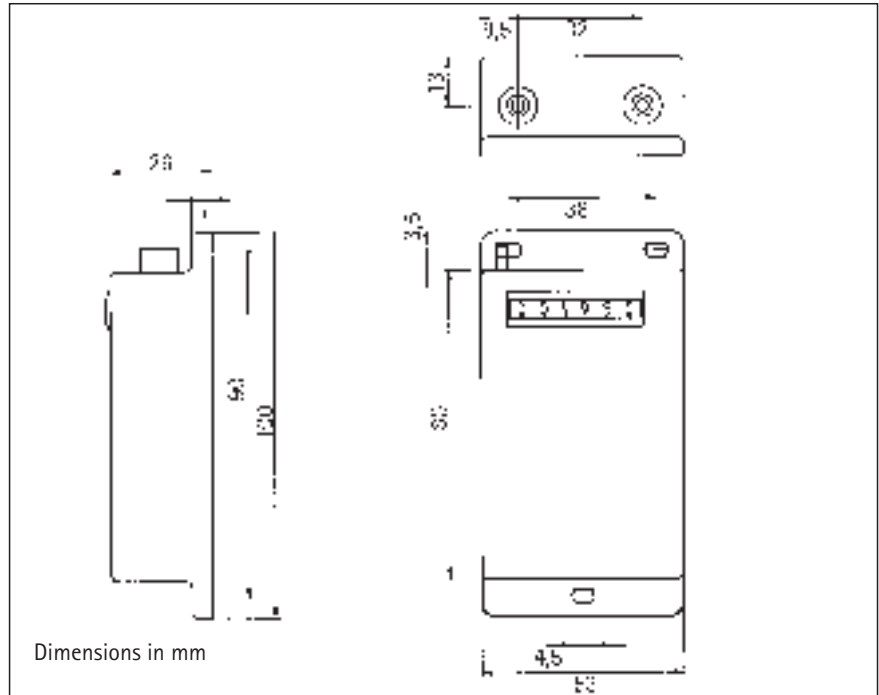

ORDER INFORMATION

Counter

Accessories

Connection	
Hose coupler M5	0 495 462
Rapid-fit connector	0 495 461
Fittings for hose M5 x 1	3 641 733
Connection kit M5/R 1/8"	1 495 089*

* on request

Pneumatic Preset Counters



- 1 Figure wheel
- 2 Rocker
- 3 Blade
- 4 Piston of the actuator system
- 5 Hose coupler
- 6 Hose coupler
- 7 Valve
- 8 Actuating lever

FEATURES

The pneumatic preset counter consists of a pneumatic actuator system, a mechanical figure wheel and a pneumatic limit switch. The counter is actuated by pneumatic pulses generated by switches, sensors, etc.

FUNCTION

Compressed air pulses exert pressure on the piston of the actuator system via the connection (hose coupler or rapid-fit coupling). The blade, loosely connected to the rocker, is actuated by the tappet. With each pulse, the rocker moves the ones drum by one half of a figure (one half-increment) and simultaneously tensions a spring which moves the drum a further half-increment as the pressure drops.

PNEUMATIC OUTPUT SIGNAL

When a set value is reached e. g. from zero, the actuating lever of the counter releases the plunger of the pneumatic counter. The valve of the switch is reversed and the output is pressurized. When the counter is reset, whether manually, pneumatically or automatically by means of an accessory module, the plunger is pressed back into initial position by the mechanical actuating lever, blocking the output signal.

SUBTRACTING PRESET COUNTER

This counter subtracts pneumatic compressed-air pulses from a set value and releases a pneumatic output signal when zero is reached.

ADDING PRESET COUNTER

This counter adds pneumatic compressed-air pulses starting from zero and releases a pneumatic output signal when the preset value is reached. The value is preset by pressing the reset key and entering the preset value. The preset value remains visible when the counter is reset.

PERMANENTLY VISIBLE PRESET VALUE

The preset value is permanently visible; it can be read at any time. Because the counting mode is adding in this case, the added sum can be assumed immediately without further calculation.

This means that the number of pieces produced or elapsed time units can be read. In addition, the preset value can be reset without resetting to zero first and is thus also possible during operation if necessary.

USE OF COUNTER

Preset counters for normal and regulating pressure can be used for a wide range of applications in pneumatic circuits and systems, the pilot and final signals acting as control elements. The counters are used for metering, as digitally adjustable timers, for presetting quantity and number of pieces, and in conjunction with pneumatic limit switches, air barriers, proximity switches, etc. The counters can be reset manually, pneumatically through an external pulse, or automatically by means of an accessory module.

MAINTENANCE

The products shown in this catalogue are maintenance-free.

MODIFICATIONS

All dimensions, technical data and other specifications represent the standard of production and knowledge attained when the material was printed. The functional features of the devices refer to the condition of the devices when new and under normal operating conditions (+ 15 to + 25 °C, non-aggressive atmosphere and neutral operating media).

The devices must be protected against freezing at temperatures under + 5 °C.

Adding Pneumatic Preset Counter Type 497



VARIABLE PILOT SIGNAL

TECHNICAL DATA

- Continuously visible preset
- Integrated pneumatic reset
- 3 or 5-digit display
- Convenient button setting

Using two pneumatic preset counters it is possible to implement pilot signals with values ranging from 1 to 99.999. These counters are especially suitable as controlling elements for semi-automatic or fully automated processes. This applies both to varying preset/setting values and to values which remain the same for a long period.

Display	3 or 5-digit indication of count and preset value, depending on version
Digit height	4 mm
Service pressure	2 ... 8 bar
Air quality	oilfree
Filter pore width	< 40 µm
Operating temperature	0 ... + 60 °C
Connection	hose coupler M5 or rapid-fit connection (depending on version)
Mounting	front panel
Mounting position	horizontal roller axis
Protection class (IEC 144)	IP 40 with hoses connected; for higher degree of protection we recommend clear covers
Count input	adding
Min. pulse length	8 ms
Max. counting frequency	20 Hz
Pulse duty factor	1:1
Reset	- manual with button - by external pneumatic signal, Min. pulse length 180 ms - automatic reset after preset has been reached (only in version with automatic reset)
Reset frequency	max. 1 per 2 s
Signal duration	from when preset has been reached until reset; at 3 bar, counter with automatic reset 300 ... 340 ms

Attention! Minimum time period between last count pulse and pneumatic reset is 50 ms.

Type 497

Technical data

DIMENSIONED DRAWINGS

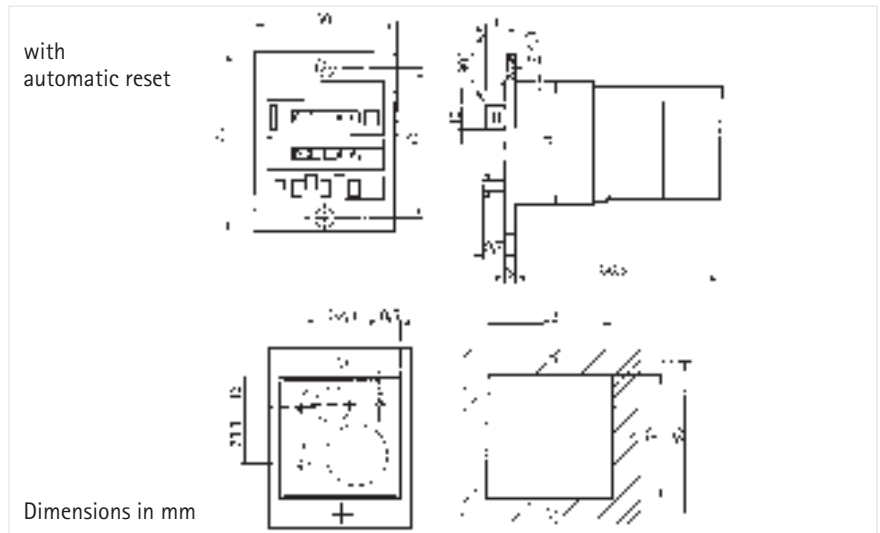
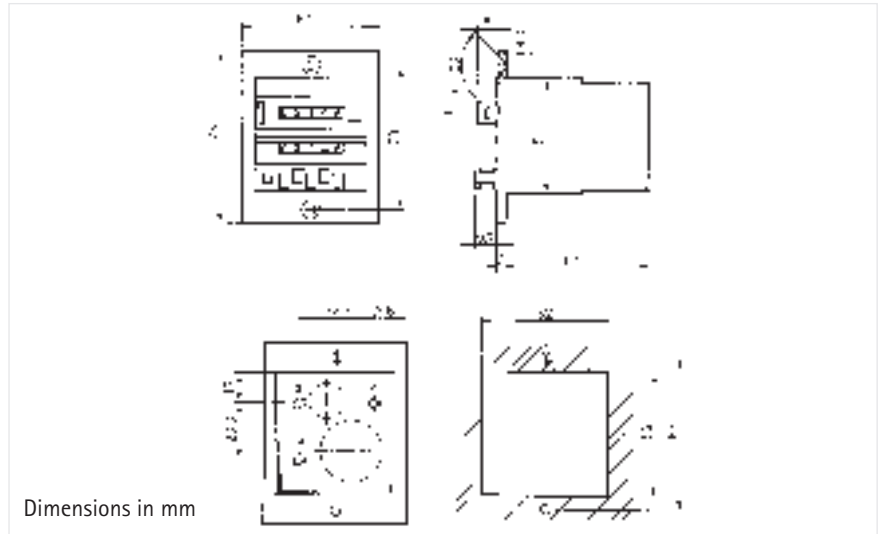

CONNECTION DIAGRAMS

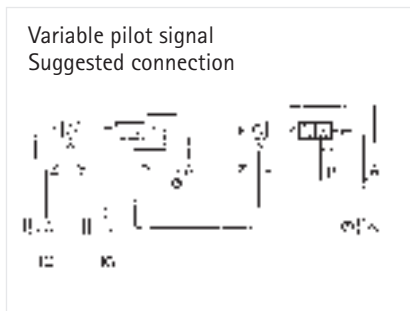
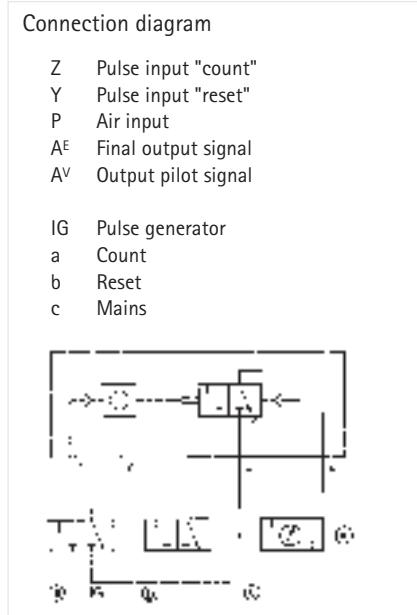
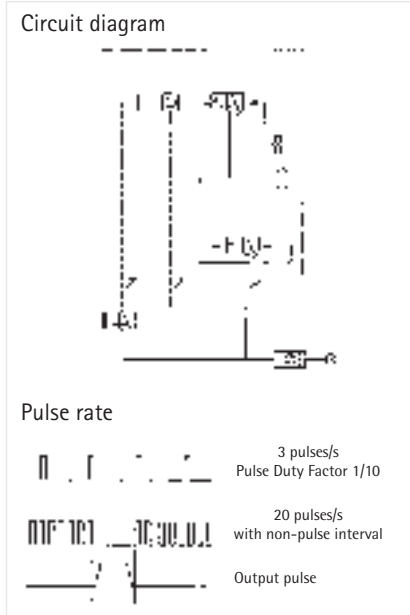

ORDER INFORMATION

Counter

Connection	Button and pneum. reset		with automatic reset	
	3-digit	5-digit	3-digit	5-digit
Hose coupler M5	0 497 619	0 497 486	0 497 493	0 497 472
Rapid-fit connector	0 497 618	0 497 487	0 497 479	0 497 473

Standard accessories

Transparent cover (description see "Accessories")				
	with knob			1 405 613
	with lock			1 405 614
Fittings M5 for hose M 5 x 1				3 641 733
Connection kit M5/R 1/8 "				1 495 089*

* on request

Type 497



TECHNICAL DATA

- Integrated pneumatic reset
- 3 or 5-digit display
- Convenient button setting

Display	3 or 5-digit count indication, depending on version
Digit height	4 mm
Service pressure	2 ... 8 bar
Air quality	oilfree
Filter pore width	< 40 µm
Operating temperature	0 ... +60 °C
Connection	hose coupler M5 or rapid-fit connection (depending on version)
Mounting	front panel
Mounting position	horizontal roller axis
Protection class (IEC 144)	IP 40 with hoses connected; for higher degree of protection we recommend clear covers
Count input	subtracting
Min. pulse length	8 ms
Max. counting frequency	20 Hz
Pulse duty factor	1:1
Reset	- manual with button - by external pneumatic signal, Min. pulse length 180 ms
Reset frequency	max. 1 per 2 s
Signal duration	from when preset has been reached until reset; at 6 bar, counter with automatic reset 300 ... 340 ms (depending on connected volume and service pressure)

Attention! Minimum time period between last count pulse and pneumatic reset is 50 ms.

DIMENSIONED DRAWING

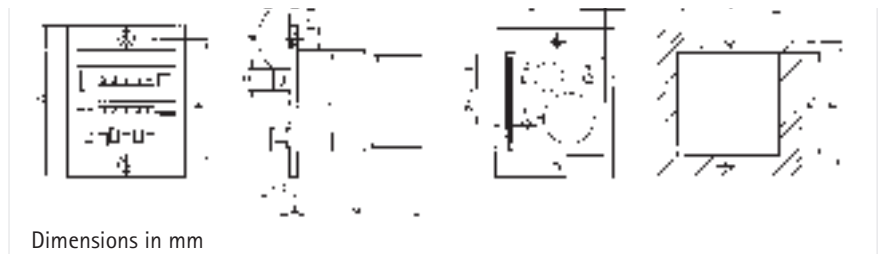

CONNECTION DIAGRAMS

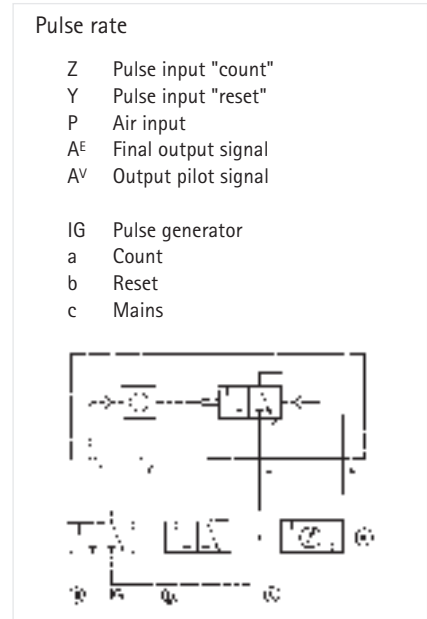
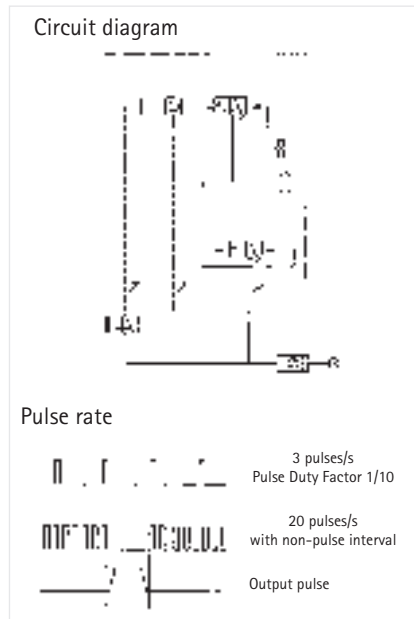

Order information

Counter

Standard accessories

Connection	Button and pneum. reset	
	3-digit	5-digit
Hose coupler M5	0 497 530	0 497 550
Rapid-fit connector	0 497 532	0 497 552
Transparent cover (description see "Accessories")		
with knob		1 405 613
with lock		1 405 614
Fittings M5 for hose M 5 x 1		3 641 733
Connection kit M5/R 1/8"		1 495 089*

* on request

Type 497



FUNCTION DESCRIPTION

- Preset value continuously visible
- Integrated pneumatic reset
- 3 or 5-digit display
- Convenient button setting



- 1 = x-input
 2 = seconds timer
 3 = minutes timer

The combination of a pneumatic minutes or seconds pulse generator and a pneumatic preset counter allows setting of times from 1 to 99999 s or 1 to 99999 min. Versions with automatic reset permit fully automatic timing sequences.

TECHNICAL DATA

Display	3 or 5-digit indication of count and preset value
Digit height	4 mm
Service pressure	2 ... 6 bar
Air quality	oilfree
Filter pore width	< 40 µm
Operating temperature	0 ... + 60 °C
Connection	hose coupler M5 or rapid-fit connection
Mounting	with front panel
Protection class (IEC 144)	IP 40 with hoses connected; for higher degree of protection we recommend transparent covers
Weight	approx. 150 g, with automatic reset module approx. 200 g
Count input	adding
Resolution	0.01 h, minute or second, dep. on version
Max. counting frequency	20 Hz
Time deviation	max. 15 % in the first second or minute
Frequency error	1/min. 0.5 %; 1/s 2 %
Reset	- manual with button - by external pneumatic signal, min. pulse length 180 ms - automatic reset after preset has been reached (only in version with automatic reset)
Reset frequency	max. 1 per 2 s
Signal output	
Signal duration	from when preset has been reached until reset; counter with automatic reset 300 ... 340 ms
Switch A	is ventilated with intake air during signal generation
Signal generation	transition P to A

DIMENSIONED DRAWING

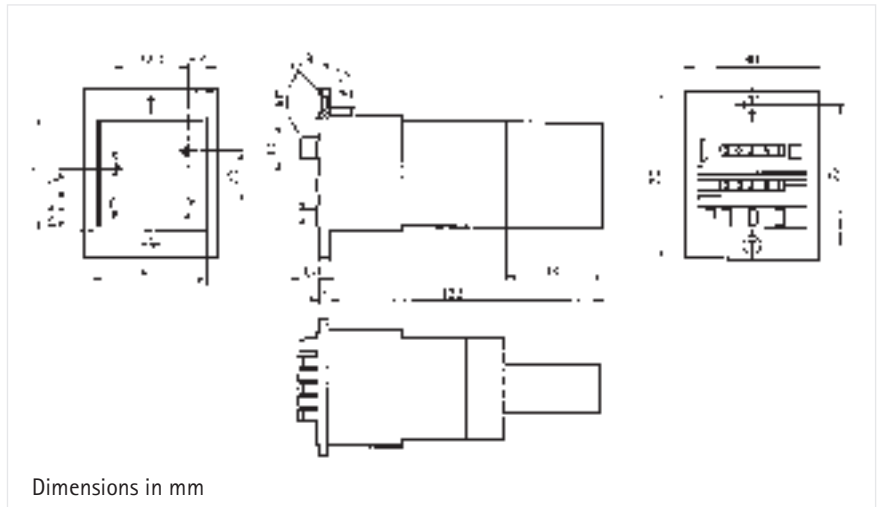

CONNECTION DIAGRAM

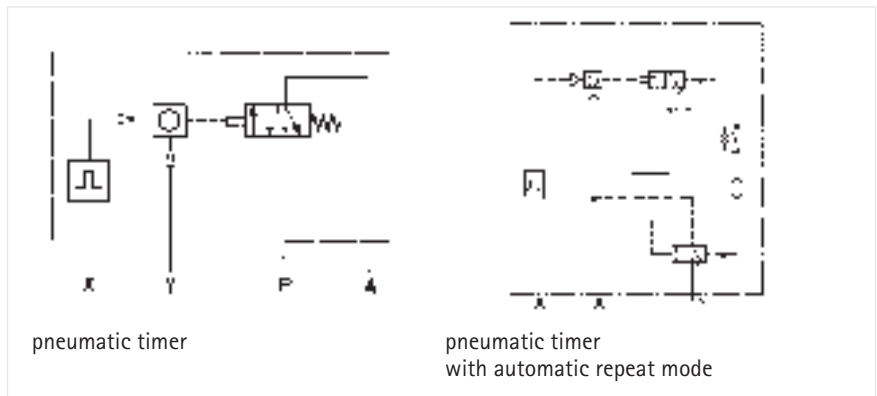

X = air intake timing element
Y = pneumatic reset

P = air intake
A = output signal

ORDER INFORMATION

Preset time counter

Standard accessories

Version		Hose coupler M5	Rapid fit connection
3-digit,	second indication	0 497 621	0 497 620
	minute indication	0 497 622	-
5-digit,	second indication	0 497 652	0 497 653
	with automatic reset	0 497 665	0 497 663
5-digit,	minute indication	0 497 654	0 497 655
	with automatic reset	0 497 666	0 497 664
Transparent cover as described under "Accessories"			
		with key	1 405 614
		with knob	1 405 613
		Fittings M5 for hose M5 x 1	3 641 733
		Connection kit M5/R 1/8 "	1 495 089*

* on request

Type 499



TECHNICAL DATA

- Low-cost
- DIN dimensions
- Requires little space for installation
- Pressure-independent
- No continuous air supply required
- Stationary preset value

Display	digit roll
Time range	0.2 ... 3 s, 2 ... 30 s or 20 ... 300 s, depending on version
Operating pressure	2 ... 6 bar
Air quality	oilfree
Filter pore width	< 40 μs
Operating temperature	0 ... + 60 °C
Connection	hose coupler M5 or rapid-fit connection, depending on version
Mounting	clamping spring or DIN rail attachment
Protection class (IEC 144)	IP 40
Weight	approx. 50 g
Input	timer is started when input 1 is pressurized
Time setting	continuous with rotary knob
Timing range	0.2–3 s 2–30 s 20–300 s
Repeating accuracy	± 0.1 s ± 0.3 s ± 3 s
Setting accuracy	± 0.3 s ± 0.6 s ± 6 s
Reset	by blocking air intake at input 1
Reset time	min. 200 ms
Output	after the set time has elapsed, input 1 is connected to output 2

CONNECTION DIAGRAM

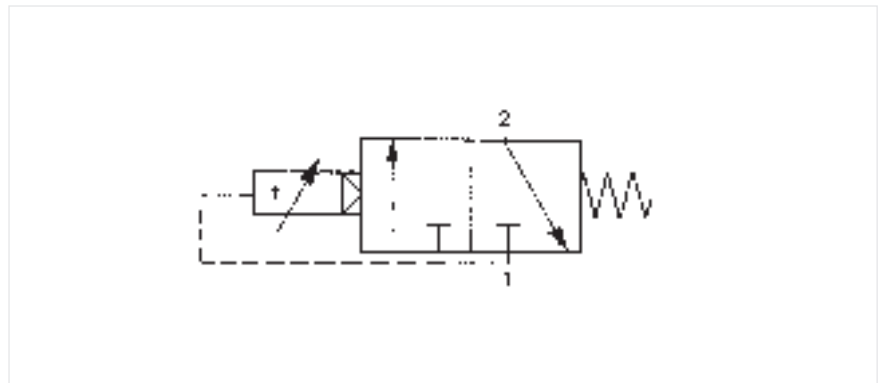

DIMENSIONED DRAWINGS

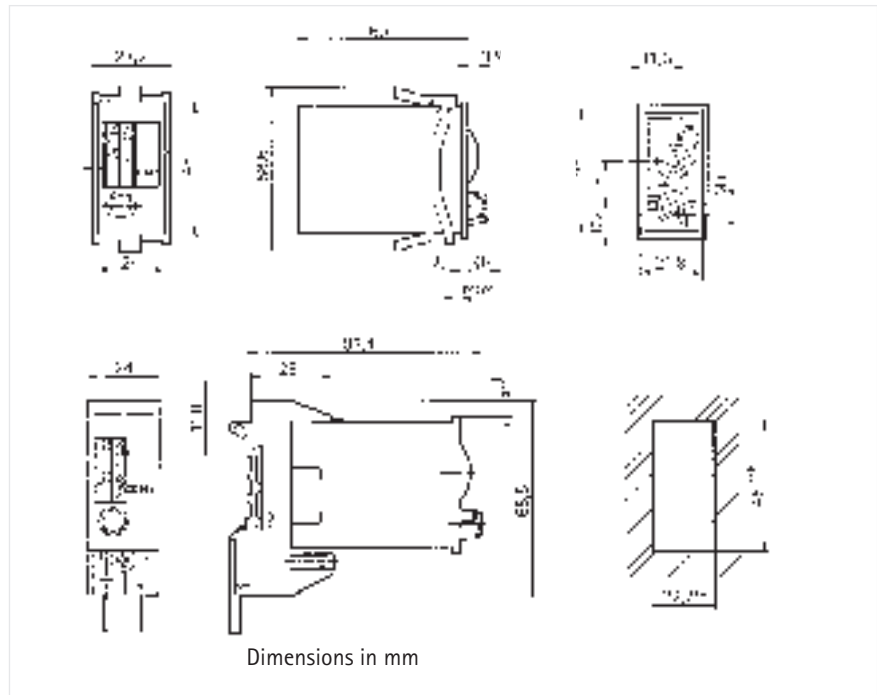

ORDER INFORMATION

Timer

	Time range	Time range	Time range
Connection	0.2 ... 3 s	2 ... 30 s	20 ... 300 s
Hose coupler M5	0 499 520	0 499 500	0 499 550
Rapid-fit connection	0 499 521	0 499 501	0 499 551

Panel frame

Dimensions	Installation dimensions	Ordering code
48 x 48 mm	45 x 45 mm	2 405 219
52 x 52 mm	45 x 45 mm	2 405 220
54 x 29 mm	50 x 25 mm	2 405 218
∅ 59 mm	∅ 50 mm	2 405 224
60 x 75 mm	52 x 52 mm	1 499 512
72 x 72 mm	68 x 68 mm	1 405 672

Accessories

Socket for DIN rail attachment		
- Hose screw coupler		1 499 511
- Rapid-fit connector		1 499 513
Please do not forget to add one of the following		
Bypass slides to your order:		
- Bypass slide for 35 mm H-rail		3 513 306
- Bypass slide for C-rail		3 513 307

Automatic reset see automatic reset module

Automatic Reset Module for Pneumatic Timers



TECHNICAL DATA
Pneumatic

- Output signal of adjustable length 0.2 to 2 seconds
- DIN dimensions
- Compact design
- Stationary preset value

Service pressure	2 ... 6 bar
Bursting pressure 12	10 bar
Nominal pressure	4 bar
Air quality	filtered (40 µm), non-oiled compressed air, light oil mist permissible

Input	
Response pressure	1.2 ± 0.4 bar
Drop pressure	0.3 ± 0.2 bar
Pulse length	min. 30 ms
Pause for reset	min. 200 ms

Time ranges	
Switching delay time	adjustable from 0.2 – 2 sec.
Signal interruption time	min. 300 ms
Repeating accuracy	± 0.3 s
based on switching delay time	

Temperature range	
Application class (DIN 40040)	KUG K = lower temperature limit: -15 °C U = upper temperature limit: + 60 °C G = average relative humidity: 65 % without condensation
Storage temperature	- 25 ... + 70 °C
Protection class (DIN 40050)	IP 40 IP 54 (with protective cover)

Mechanical

Substances which inhibit application of paint according to VW test specification no. 3.10.7	
Dimensions	24 x 48 x 68 mm (W x H x D)
Insertion depth without connect.	57.5 mm
Front panel cutout	22.2 ^{+0.3} x 45 ^{+0.6} mm (W x H) (Other front panel cutout dimensions possible with additional panel frame)

Mounting	
for front panel insertion	by means of clamping frames
Pneum. connections	M5 or rapid-fit coupling for hoses with 4 mm external diameter
Tightening torque for connections	max. 250 Ncm
Mounting position	any
Weight	approx. 50 g

Automatic Reset Module

DIMENSIONED DRAWING

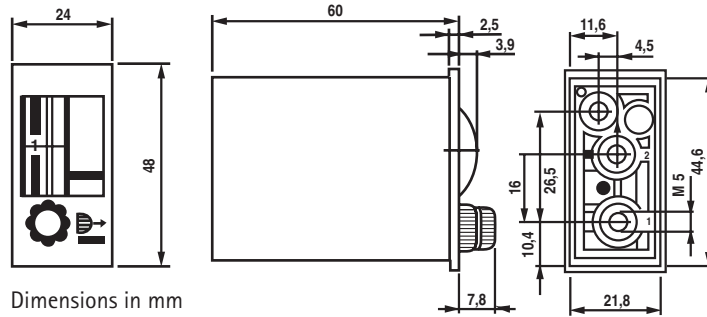

Dimensions in mm

Front panel cutout

Installation of the reset module in combination with a timer in a cutout measuring 54 x 50 mm is possible with two front panels of 54 x 29 mm (spacers).

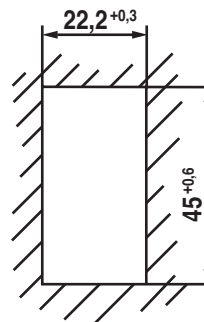

for reset modules

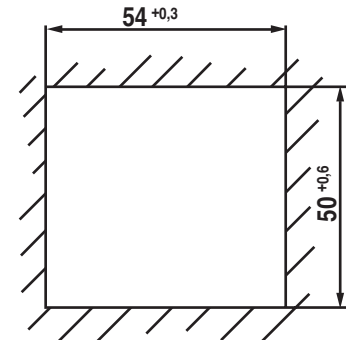

for combined installation with timer

CONNECTION DIAGRAM

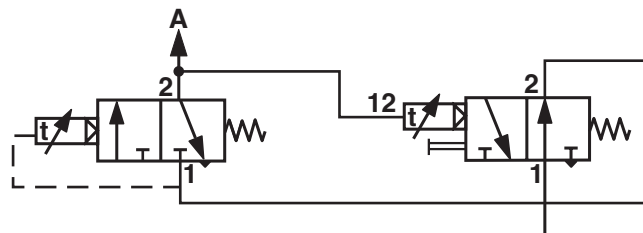

Reset module - timer

ORDER INFORMATION

Accessories

	Ordering code
Pneum. reset module M5	0 499 350
Pneum. reset module rapid-fit coupling	0 499 351
Front panel 54 x 29 mm	2 405 218

(For further accessories, please refer to the pneumatic timers)

Pneumatic Proximity Switch



- Non-contact actuation
- Miniature dimensions
- Can be actuated by magnetic field and iron
- No continuous air consumption

TECHNICAL DATA

Service pressure	2 to 6 bar
Air quality	oilfree
Filter pore width	≤ 40 µm
Operating temperature	- 10 °C ... + 60 °C
Connection	plug fitting for hose NW 3
Nominal width	2 mm
Actuating distance	for Fe: approx. 2 mm
Distance switch - switch	min. 20 mm
Distance switch to steel parts	min. 15 mm
Mounting	thread M4 or strap retainer
Sensing	non-contact (also through a wall of non-magnetic material)

CONNECTION DIAGRAM



DIMENSIONED DRAWING

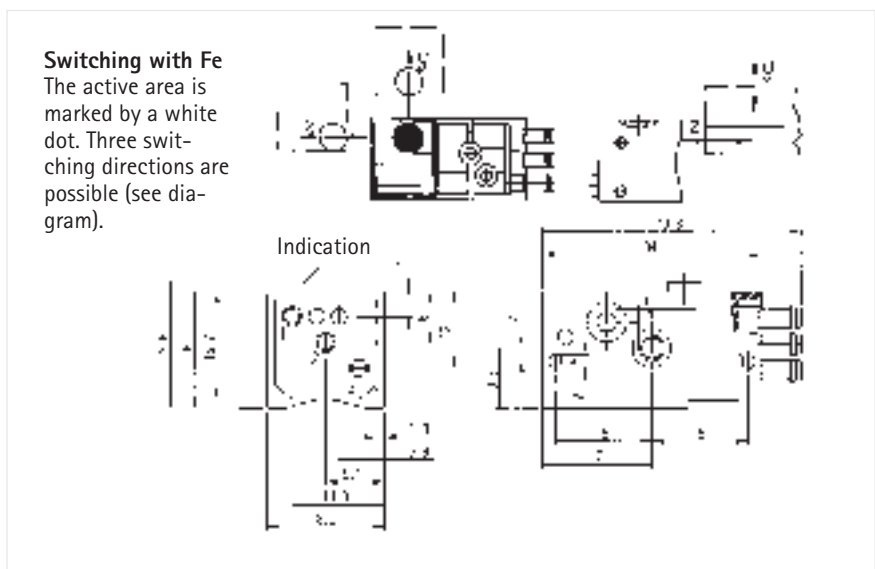

ORDER INFORMATION

	Ordering code
Pneumatic proximity switch	0 490 300
Strap retainer attachment up to 100 mm ø	1 490 205

Pneumatic Signal Indicator



- Signals the operating status of pneumatic hose connections
- Simple installation
- Connections for hoses with 2 or 3 mm inside diameter
- Service pressure 2...8 bar

TECHNICAL DATA

Indication	yellow signal as long as a line is pressurized
Service pressure	2 ... 8 bar
Air quality	filtered, light oil mist permissible
Filter pore width	< 40 µm
Operating temperature	- 15 ... + 60 °C
Storage temperature	- 25 ... + 70 °C
Connection	hose with 2 or 3 mm inside diameter, dep. on version
Mounting	at connection hose
Vibro stability	50 m/s ² (10 ... 500 Hz) acc. to IEC 068-2-6
Shock stability	500 m/s ² (5 ms) acc. to IEC 068-2-27
Maintenance-free operation	> 30 million switching operations
Weight	2 g

DIMENSIONED DRAWING

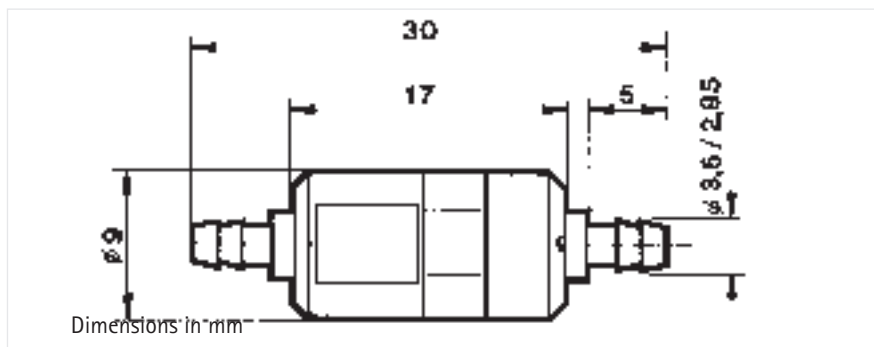

ORDER INFORMATION

Signal indicator for hoses with 2 mm inside diameter	Ordering code 0 499 210
Signal indicator for hoses with 3 mm inside diameter	Ordering code 0 499 211

Notes