

Position Indicators

Position indicators process the angle or path information that is provided by appropriate pulse generators and thus enable positions to be determined.

Application:

Machines with adjustable limit stops (machine tools, paper processing machinery, saws, wood working machines etc.)

The diverse range offers the possibility of monitoring and protecting limit stops as well sending positional data to control systems.

Typical applications:

- Visual display at processing machines
- Tool machines
- Paper machines
- Saws
- Extruders
- Wood working machines
- Elevators
- Lifting equipment
- Earth drilling equipment
- Cable laying equipment
- Lock control
- Crane systems
- Measurement techniques

Electronic Position Indicators



Type	tico 731	tico 734 002	tico 735	signo 727
Features	<ul style="list-style-type: none"> ■ Small, compact, 5 different versions ■ Voltage supply 12-24 VDC ■ 8-digit LCD or 6-digit LED display ■ Optional with prescaling and decimal point function 	<ul style="list-style-type: none"> ■ Position indicator with large dual-color, 8-digit LCD display; illuminated ■ Reproducible, freely selectable set value ■ Programmable prescaling and decimal point functions ■ Voltage supply via exchangeable Li cell ■ Small mounting depth ■ Expandable by a variety of optional modules ■ 10 versions of the same design offering different functions 	<ul style="list-style-type: none"> ■ Large dual-colour, 5-digit LED display, digit height 18.5 mm ■ Programmable colour change ■ Reproducible, freely selectable set value ■ 2 preset values ■ Upgradable options: RS 485, linear output ■ Easy to service due to modular system ■ Complete functions by 8 counter versions and 5 process indicators 	<ul style="list-style-type: none"> ■ Large 6-digit LED display, digit height 14 mm ■ Voltage supply 12-24 VDC or 115/230 VAC ■ Plug-in screw terminal connections ■ Very high counting frequency up to 40 kHz ■ Without, or with 2 limit values (as relay and transistor) ■ Indication of chain values or absolute values ■ Optional with RS 232 or RS 485 interface
Technical Data				
Dimensions (mm) (Width x Height x Depth)	48 x 24 x 60	72 x 36 x 36	96 x 48 x 100	96 x 48 x 108
Front panel cutout (mm)	45 x 22.5	68 x 33	92 x 45	92 x 45
Display	LCD 8-digit, 7 mm LED 6-digit, 7.6 mm	LCD 8-digit, 12 mm illuminated	LED 5-digit, 18.5 mm Dual-colour	LED 6-digit, 14 mm
Protection	IP 65	IP 65	IP 66	IP 54
Supply voltage	12-24 VDC	Lithium battery, exchangeable	22-55 VDC / 20-50 VAC or 90-264 VAC	12-24 VDC; 24 VAC or 100-240 VAC
Temperature range	-10-50 °C	0-50 °C	0-55 °C	0-50 °C
Inputs				
Input control	PNP/NPN	PNP/NPN	PNP/NPN	PNP/NPN
Frequency	2 kHz	10 kHz / 30 Hz	10 kHz / 200 Hz / 20 Hz	40 kHz / 30 Hz
Count Mode	Phase discriminator (single)	Phase discriminator (single)	Phase discriminator (single)	Phase discriminator (single, dual, quadruple)
Prescaling factor	Optional 0.001-99.999	Optional 0.001-99.9999	0.0001-9.9999	0.0001-99.999
Set value		Programmable	Programmable	Programmable
Reset input	PNP/NPN	NPN	NPN	PNP/NPN
Control inputs		Keylock	Keylock	Keylock; display hold and reset enable
Output			Optional with linear output; 1 or 2 relay and transistor outputs	Without, or with 2 relay and transistor outputs
Page	282	286	289	292

Electronic Position Indicators



Type		signo 727 SSI		
Features	<ul style="list-style-type: none"> ■ Large 6-digit LED display; digit height 14 mm ■ Voltage supply 12-24 VDC or 115/230 VAC ■ SSI (Synchronous Serial Interface) input for absolute encoder ■ Freely scaleable display ■ Connections via plug-in screw terminals ■ Chain value or absolute value indication ■ Without, or with 2 limit values as relay and transistor 			
Technical Data				
Dimensions (mm) (Width x Height x Depth)	96 x 48 x 108			
Front panel cutout (mm)	92 x 45			
Display	LED 6-digit, 14 mm			
Protection	IP 54			
Supply voltage	12-24 VDC or 115/230 VAC			
Temperature range	0-50 °C			
Inputs				
Input control	SSI			
Baud rate	100 kHz			
Counting mode	SSI for single-turn and multiturn encoders up to 24 bit			
Prescaling factor	Resolution programmable per revolution			
Set value	Programmable			
Reset input	PNP/NPN			
Control inputs	Keylock and reset/display hold input			
Output	Without, or with 2 relay and transistor outputs			
Page	299			

tico 731

Flexible Counter Series in DIN size 24 x 48 mm



- high contrast 8-digit LCD display or brilliant 6-digit LED display
- different supply voltages available:
 - independent of mains supply with lithium battery or
 - maintenance-free and environmentally friendly with 12-24 V DC supply
- also high-voltage input 12-250 V AC/DC
- up to 8 different functions for each standard model:
 - 01 pulse counter
 - 02 tachometer (1/min)
 - 03 time counter (hhhh:mm:ss)
 - 04 time counter (hhhhh,hh)
 - 05 numerical display for the PLC (serial)
 - 06 bidirectional position indicator
 - 07 counter with differential mode
 - 08 maintenance counter (on request)

OVERVIEW



Standard Models	Type 1	Type 2	Type 3	Type 4	Type 5
Hardware					
Display	8-digit LCD	8-digit LCD	8-digit LCD	8-digit LCD	6-digit LED
Supply voltage	Lithium battery	12 – 24 VDC	Lithium battery	12 – 24 VDC	12 – 24 VDC
Nominal data retention	7 years	NV-FRAM > 10 years	7 years	NV-FRAM > 10 years	NV-FRAM > 10 years
Active edge negative or positive edge programmable	x	x	x	x	x
Amplitude thresholds	< 0.7 and > 5 V, max. 30 V DC	< 0.7 and > 5 V, max. 30 V DC	< 3 V and > 12 V max. 250 V DC/AC	< 0.7 and > 5 V, max. 30 V DC	< 0.7 and > 5 V, max. 30 V DC
Counting frequency programmable	max. 7.5 kHz or 30 Hz attenuated	max. 7.5 kHz or 30 Hz attenuated	20 Hz	max. 7.5 kHz or 30 Hz attenuated	max. 7.5 kHz or 30 Hz attenuated
Control inputs	Reset and Keylock	Reset	Reset and Keylock	Reset and application input	Reset and application input
Keylock	external input	programmable	external input	programmable	programmable
Mounting depth	32 mm	32 mm	60 mm	60 mm	60 mm
Software					
Impulse counter	x	x	x	x	x
Tachometer 1/min	x	x		x	x
Time counter h : 1/100 h	x	x	x	x	x
Time counter h : min : s	x	x	x	x	x
Numerical display for PLC		x		x	x
Position indicator				x	x
bi directional					
Counter with differential mode					x
Maintenance counter (on request)					x

TYPE 4



TECHNICAL DATA

- LCD display
- 12-24 V DC supply voltage
- COUNT: count input for voltage signal (positive, 2 kHz)
- INPUT 2: second count input for position indicator
- RESET: reset input
- Long case

Operating temperature	-10 ... 50 °C
Storage temperature	-20 ... +60 °C
Electrical connection	screw terminals
Mounting	with clamping frame
Front panel cutout	45 + 0.6 x 22 + 0.3 mm
Protection class (IEC 144)	front side IP 65, terminals IP 20
Dynamic strength	10 m/s ² (10 ... 150 Hz) according to IEC 68-T2-6
Shock stability	100 m/s ² (18 ms) according to IEC 68-T2-27
General rating	according to EN 61010, protective system II
Pulse shape	any square wave (1:1 for max. frequency)
Input resistance	< 50 kOhm (static)
Min. pulse length	17 ms (30 Hz), 70 µs (7.5 kHz)
Display	8-digit LCD, 7 mm
Supply voltage U _b	12 ... 24 V DC
Ccurrent consumption DC	12 ... 24 V DC < 50 mA
Nominal data retention	nonvolatile memory > 10 years
Count input:	
Amplitude thresholds	voltage input up to 2 kHz: < 0.7 V and > 5 V, max. 30 V DC
Active edge	positive edge
Counting frequency	with position indicator 2 kHz: active edge positive
Control inputs:	
Reset	- manual reset via keyboard (can be locked) - external reset with static behaviour, 30 Hz attenuated same edge as with count input
Input 2:	second count channel; same edge as with count input
Reset lock	programmable via front key
Counting frequency	max. 2 kHz

DIMENSIONS CONNECTION DIAGRAM

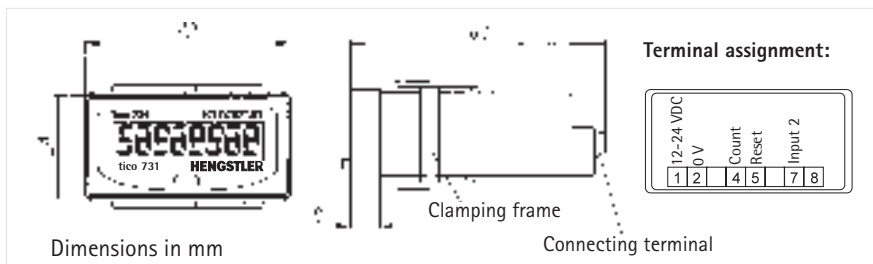

ORDER NUMBER

Model tico 731

0 731 4 0 6

Software function

- 01 impulse counter
- 02 tachometer (1/min)
- 03 time counter (hhhh:mm:ss)
- 04 time counter (hhhhhh.hh)
- 05 numerical display for PLC
- 06 bidirectional position indicator

tico 731

TYPE 5



TECHNICAL DATA

- LED display
- 12-24 V DC supply voltage
- COUNT: count input for voltage signal (positive, 2 kHz)
- INPUT 2: second count input for position indicator
- RESET: reset input
- Long case

Operating temperature	-10 ... 50 °C
Storage temperature	-20 ... +60 °C
Electrical connection	screw terminals
Mounting	with clamping frame
Front panel cutout	45 + 0.6 x 22 + 0.3 mm
Protection class (IEC 144)	front side IP 65, terminals IP 20
Dynamic strength	10 m/s ² (10 ... 150 Hz) according to IEC 68-T2-6
Shock stability	100 m/s ² (18 ms) according to IEC 68-T2-27
General rating	according to EN 61010, protective system II
Pulse shape	any square wave (1:1 for max. frequency)
Input resistance	< 50 kOhm (static)
Min. pulse length	17 ms (30 Hz), 70 µs (7.5 kHz)
Display	6-digit LED, 7 mm
Supply voltage U _b	12 ... 24 V DC
Current consumption DC	12 ... 24 V DC < 50 mA
Nominal data retention	nonvolatile memory > 10 years
Count input:	
Amplitude thresholds	voltage input up to 2 kHz: < 0.7 V and > 5 V, max. 30 V DC
Active edge	positive edge
Counting frequency	with position indicator 2 kHz
Control inputs:	
Reset	- manual reset via keyboard (can be locked) - external reset with static behaviour, attenuated same edge as count input
Input 2:	second count channel, same edge as count input
Reset lock	programmable via front key
Counting frequency	max. 2 kHz

DIMENSIONS CONNECTION DIAGRAM

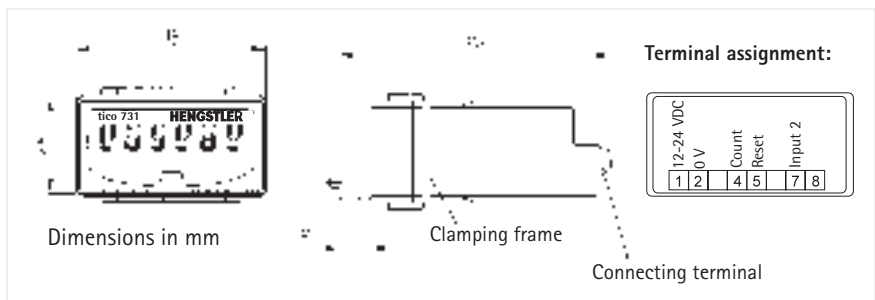

ORDER NUMBER

Model tico 731

0 731 5 0 6

Software function

- 01 impulse counter
- 02 tachometer (1/min)
- 03 time counter (hhh:mm:ss)
- 04 time counter (hhhhh.hh)
- 05 numerical display for PLC
- 06 bidirectional position indicator**
- 07 counter with differential mode (1 kHz)

SPECIAL FUNCTIONS

To best match your application, you can order special functions such as prescaler value, decimal point and preset value, which are permanently set by us before delivery. With the variable prescaler value you can adapt to already existing transfer ratios of your application. Small resolutions can be shown with the decimal point, e. g. for the position indicator or the tachometer.

A special feature is the possibility of displaying an information text in the display, e. g. for the surveillance of maintenance cycles. In this case the desired information is shown in the display after reaching the fixed preset value. You can display any text that can be created with the 7-segment alphabet, e. g. STOP, HELP, FILTER etc.

ORDER NUMBER SPECIAL VERSIONS

Special functions for	Impulse counter	Tacho- meter	Time counter	Numerical display	Position indicator	Counter with differential work
Preset value 0.000015 to 65535.99998	x	x			x	x
Decimal point 0 to 3 positions behind the comma	x	x			x	x
Preset value 0 to 99 999 999	x		x			
Information text (on reaching the preset value) LCD = 8 characters LED = 6 characters	x		x			

ORDER NUMBER SPECIAL VERSIONS

Choose version and basic function:

Model tico 731



* Option: with plug-in screw terminals only for standard model 1, 2

Standard version:

- 1 Standard model 1
- 2 Standard model 2
- 3 Standard model 3
- 4 Standard model 4
- 5 Standard model 5

Function:

- 1 Impulse counter
- 2 Tachometer (1/min)¹⁾
- 3 Time counter (hhhh:mm:ss)
- 4 Time counter (hhhhh.hh)
- 6 Position indicator (2-channel)²⁾
- 7 Counter with differential mode³⁾

- 1) not available for standard type 3
- 2) not available for standard types 1, 2, 3
- 3) only available for standard type 5

Please state the desired special version on your order:

P: (Value);

Prescaler value: 0.000015 to 65535.99998⁴⁾
Type 4 and 5: to 99,999

D: (Value);

Decimal point: 0 to 3 positions after the comma⁴⁾

V: (Value);

Preset value: 0 to 99 999 999⁵⁾

T: (Text);

The information text displayed on reaching the preset value can be built up as required from the 7-segment alphabet

- 4) not available for time counters
- 5) not available for tachometers and position indicator

tico 734



MODEL OVERVIEW

Position Indicator (0 734 002)
 8 digit, prescaler 0.0001 to 99.9999,
 decimal point, reset value range

Flexible Counter Series in DIN size 36 x 72 mm

- LCD, 8 digits, 12 mm height, excellent contrast through supertwist technology
- Backlighting with a 10-28 VDC supply
- Lithium battery power supply
- Decimal point, input scaling, count direction, output mode, etc. programmable, depending on model
- Magnetic pick-up input enables a rate measurement system not requiring external power
- Programming reduced to a minimum for easy handling and set-up
- CE approval, IP 65, NEMA 4

The family **tico 734** consists of ten models:

- 0 734 000 Totalizer without scaling
- 0 734 001 Add/Subtract totalizer
- 0 734 002 Position indicator
- 0 734 003 Tachometer
- 0 734 004 Programmable rate meter
- 0 734 005 Rate meter with totalizer
- 0 734 006 Time counter
- 0 734 007 Preset counter
- 0 734 008 Time preset counter
- 0 734 009 Rate meter 005; with total and pulsed output

Reset	— 4	5	— Progr.		4 Remote reset, NPN
A:30 Hz	— 3	6	— B:30 Hz		3 Input A, 30 Hz, NPN
A:10 kHz	— 2	7	— B:10 kHz		2 Input A, 10 kHz, PNP
0V	— 1	8	— 10-28 VDC		1 0V, Common
					5 Program enable
					6 Input B, 30 Hz, PNP
					7 Input B, 10 kHz, PNP
					8 DC-supply for backlighting

Suitable option modules: 1 734 0.. 10, 12, 14, 17, 19

Power Supply

Internal Single or dual lithium 3 V battery (CR 1/2 AA), typical life time of 5 years (10 yrs w/2 batteries). „Lo BAT" display flashes approximately 2 weeks prior to end of battery life.

Display

via Option Module 120/240 VAC provides 12 VDC for display backlighting

Display LCD, 12 mm height, 8 digits

Backlighting Whole display area can be backlit with a 10-28 VDC supply, green-yellow colour

Count Inputs

High Speed Input (2) PNP, ≤ 28 VDC, max. 10 kHz (50% duty cycle), Low < 1.0 V, High > 2.0 V, impulse > 45 μ s, impedance 1 M Ω

Low Speed Input (3) NPN, ≤ 28 VDC, max. 30 Hz (50% duty cycle), Low < 1.0 V, High > 2.0 V, impedance 1 M Ω

High Voltage Option Module 100..260 VAC/DC, 30 Hz, 1 M Ω , with internal connection to input (3)

Low Voltage Option Module 5..30 VAC/DC, 30 Hz, 17 k Ω , with internal connection to input (3)

Control Inputs

Enable Input (5) NPN, 28 VDC, level sensitive

Reset Input (4) NPN, 28 VDC, edge triggered, max. 30 Hz (50% duty cycle)

Physical

Mounting Front panel mounting with mounting bracket

Dimensions DIN 36 x 72 mm, 36 mm total depth, total width 83 mm

Panel Cutout $33^{+0.3}$ mm x $68^{+0.3}$ mm, depth behind panel < 29 mm

Panel Thickness max. 8 mm

Environmental

Front Panel Rating IP 65 / NEMA 4

Operating and Storage Temperature 0 $^{\circ}$ C to $+ 55$ $^{\circ}$ C

$- 20$ $^{\circ}$ C to $+ 60$ $^{\circ}$ C

General DIN EN 61010 part 1 / VDE 0411 part 1
Protection according to class II, Contamination level 2
Overvoltage category II

DIMENSIONS

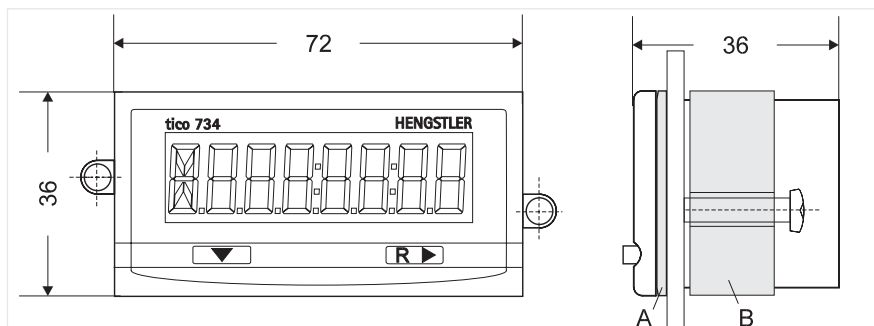

1) Panel cutout: 33 x 68 mm

A: gasket, B: mounting bracket

Dimensions in mm

tico 734

OPTION MODULES

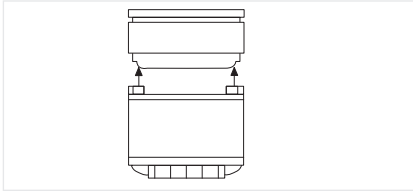

FUNCTIONS OVERVIEW

TECHNICAL DATA

WIRING

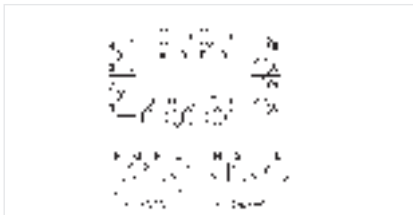

ORDERING INFORMATION

Technical data

With the Option Modules, the **tico 734** can be functionally extended and adapted to special application conditions. The following option functions are available:

- AC power supply providing sensor supply 10-20 VDC / 50 mA and 12 V supply for display backlighting (supports the battery in models with SSR output)
- Relay output, changeover contact, 5 A, 120/240 VAC or 30 VDC
- High voltage input (100..260 VAC/DC, max. 30 Hz, 200 KΩ)

1734 ...

	Connections	010	011	012	013	014	015	016	017	018	019	020
High Voltage Input	C-D	x		x	x		x					
Relay 1 x change over	A-B-J		x		x		x	x		x		x
AC power Supply	E-F, G-H			x		x	x	x			x	x
Low Voltage Input	C-D								x	x	x	x

Power Supply (E-H)	115 VAC or 230 VAC (see wiring), frequency 50/60 Hz. Terminal (8) provides an unregulated 10-20 VDC supply for powering sensors up to 50 mA
Relay Output (A-B-J)	Type: SPDT (Form C) mechanical relay; Operate Time: 6 ms 5A, 120/240 VAC or 30 VDC, silver alloy Electrical Life: > 500 000 operations, Mechanical Life: > 10 million operations
High Voltage Input (C-D)	Voltage Range: 100 to 260 VAC or VDC Count Speed: max. 30 Hz. (duty cycle 50 %) Minimum Pulse Width: 12 ms; Impedance: 200 kOhm
Low Voltage Input (C-D)	Voltage Range: 5 to 30 VAC or VDC Count Speed: max. 30 Hz. (duty cycle 50 %) Minimum Pulse Width: 12 ms; Impedance: 127 kOhm
Mounting	Attaching on back of instrument
Dimensions	42 x 69 mm, depth 58 mm, total depth behind panel with instrument 82 mm
Temperature	Operating: -0° C to +50° C; Storage -40° C to +90° C;
General	DIN EN 61010 part 1, Protection according to class II Contamination level 2; Overvoltage category II

All modules contain 17 terminals. The exact functions that are present are determined by the model of instrument and option module (see Functions Overview).

1-8 Connection to instrument (refer to appropriate operating instructions)

A	Normally Open Relay Contact
B	Relay Common
J	Normally Closed Relay Contact
C-D	High or Low Voltage Input, no polarity, (provides NPN signal on terminal 3)
E-F	115 VAC Line winding I
G-H	115 VAC Line winding II

Panel Instruments	
Totalizer	0 734 000
Add/Subtract Totalizer	0 734 001
Position Indicator	0 734 002
Tachometer	0 734 003
Programmable Rate Meter	0 734 004
Rate Meter with Totalizer	0 734 005
Elapsed Time Indicator	0 734 006
Preset Counter	0 734 007
Preset Timer	0 734 008
Rate Meter with Total and Pulsed Output	0 734 009
Lithiumbattery	E3533 355

Option Modules	
HV Input	1 734 010
Relay	1 734 011
AC Power	1 734 012
HV Input and Relay	1 734 013
HV Input and Power	1 734 014
Power and Relay	1 734 015
HV Input/Power/Relay	1 734 016
LV Input	1 734 017
LV Input and Relay	1 734 018
LV Input and Power	1 734 019
LV Input/Power/Relay	1 734 020

Flexible Counter Series, tico 735

Dual Colour Display in DIN size 48 x 96 mm



FEATURES

COUNTING - MEASURING - INDICATING - MONITORING - TRANSMITTING

Because of the unlimited number of measurements it can handle, the **tico 735** device family is equally well suited to applications in the world of impulse and time counting as to those in the processing area.

If you are looking for display clarity and high levels of accuracy, then the **tico 735** is the right choice for you. The dual-colour display is unique, highlighting an alarm situation or an excess value at a single glance. You can program your own choice of display colour to indicate normal or alarm conditions.

- Brilliant 18.5 mm high dual-colour red/green LED display with programmable colour settings
- As standard, all models have limit or preset values
- Scaling available as standard
- Universal Power Supply 90...264 V AC or 20...50 V AC/DC
- Simple structured operation with switchable help function

- External Program Lockout
- DIN housing 48 x 96 mm, mounting depth < 100 mm
- Conveniently sized Screw Terminals
- Large keys offer safety and ease of operation

- NPN and Relay Outputs
- Option: RS 485 ASCII protocol serial interface for all versions. "Remote Display" version receives process values over RS 485

POSITION INDICATOR

Input Modes, Features	Value Range
Quad	-19999...99999
Upper and Lower Range Limits	-19999...99999
Set Value	-19999...99999
Option: Linear Output, scalable, isolated	0/4-20 mA, 0/1-5 V, 0/2-10 V

tico 735

Technical data

DIMENSIONS

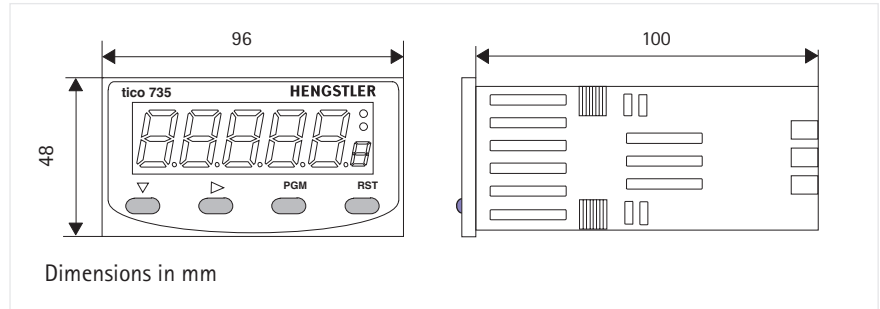

DISPLAY AND KEYBOARD

Primary Display	Red/Green, 7 segment LED, 5 digits, height 18.5 mm
Secondary Display	single digit 7 segment LED, height 7 mm, red/green
Output Indicators	2 red LEDs for OUT 1 and OUT 2 status
Keyboard	4 rubber keys for programming and manual reset

PHYSICAL

Front Dimensions	DIN 48 mm x 96 mm, 110 mm total depth
Mounting	Front panel mounting (mounting bracket supplied)
Panel Cutout	45 mm x 92 mm, panel thickness max 12 mm
Construction	Front carrier with PCBs can be pulled out
Terminals	Screw Type (combination head)

OPERATING CONDITIONS

Power Supply	90 - 264 V AC 50/60 Hz (electrically separated from all inputs and outputs) or 20...50 V AC / 22...55 V DC
Temperature	Operation: 0 °C to +55 °C (32 °F to 131 °F) Storage: -20 °C to +60 °C (-4 °F to 176 °F)
Relative Humidity	0 to 90 %, non-condensing

APPROVALS

Protection class	Frontpanel IP 66
CE	EN 50082-1/92-95; EN 50081-1/92, -2/94
Safety	DIN EN 61010 part 1; protection according to class II
General	UL, CUL, Overvoltage cat. II, Contamination level 2

OPTION LINEAR OUTPUT

Insulation	optically isolated, 250 V AC or 400 V DC from all inputs and outputs
Output Ranges	0-20 mA, 4-20 mA, 0-10 V, 2-10 V, 0-5 V, 1-5 V
Accuracy	± 0.25 % (mA on 250 Ohms, V at 2 kOhm); Deviation ± 0.5 %
Resolution	8 bits after 250 ms (10 bits after 1000 ms typically)
Updates	approx. 4 per second
Load	mA: max 500 Ohm, V: min. 500 Ohm

OPTION RS 485

Type	RS 485, serial asynchronous, Open ASCII, Master-Slave, up to 99 zones
Parameters	9600...1200 Bd, 1 start, 7 data, 1 stop, even parity

TERMINALS

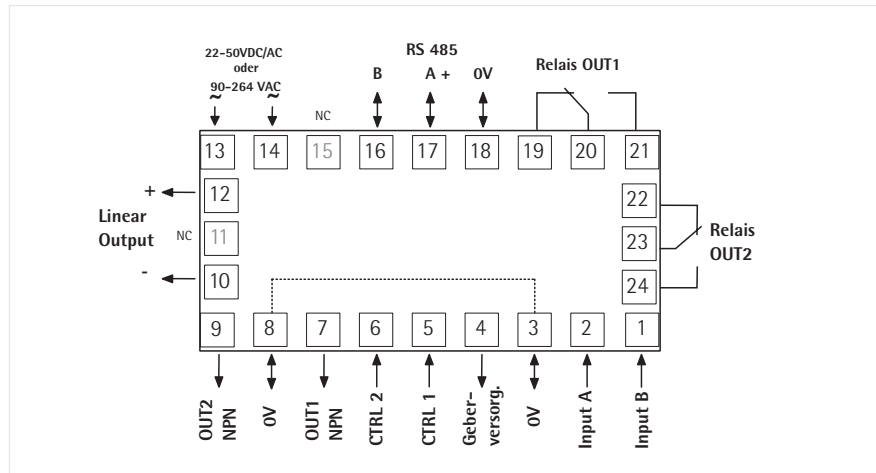

COUNT INPUTS

Active Edge with PNP	NPN or PNP programmable; capable of TTL; 30 V DC max High ≥ 3.0 V, Low < 2.0 V or open; 10 kOhm to 0 V
with NPN	High ≥ 3.0 V or open, Low < 2.0 V; 4.7 kOhm to V+
Frequency	20 Hz, 200 Hz or 10 kHz programmable

CONTROL INPUTS

CTRL 1 (Reset)	NPN; High ≥ 3.0 V or open, Low < 2.0 V; 4,7 kOhm to V+ edge sensitive; 25 ms min., max 30 V DC
CTRL 2 (Progr. security))	NPN; High ≥ 3.0 V or open, Low < 2.0 V; 4,7 kOhm to V+ level sensitive; 25 ms min.; max 30 V DC

OUTPUTS

OUT 1 NPN	NPN, open collector; 30 V DC max; 100 mA max
OUT 2 NPN	response time $< 75 \mu\text{s}$
Relay 1, Relays 2 (opt.)	Changeover (Form C); 240 V AC / 3A or 110 V AC / 5 A; pull-in time 8 ms
Auxiliary Power Supply	9...15 (unregulated V DC), 125 mA max; residual ripple < 0.5 V

SPECIAL FEATURES

- Display colour programmable
- Preset Lockout and Reset Disable programmable
- Program Security via CTRL 2
- Optional Linear Output
- Scaling available as standard

Type 0735 P

0 7 3 5 P

Output Relay 2

0 none
1 with Relay 2 nicht für Funktion 1, 6, 7

Interface

0 none
5 with RS 485

Function

1 Totalizer
2 **Position Indicator**
4 Tacho/Rate Meter
5 Rate + Totalizer
6 Time Counter
7 1 Preset Counter
8 2 Preset Counter
9 Batch Counter

Linear Output

0 none
3 with 4-20 mA (only with function 2, 4, 5)

Option module

Relay 2
Linear output
RS 485 interface

Power Supply

0 90...264 V AC
2 20...50 V AC or 22...55 V DC

Ordering code

1 901 001
1 901 003
1 901 004

signo 727.1



APPLICATION FIELDS

DISPLAY

PROGRAMMING

Position Indicator with/without Limit Values

- Large, 6-digit, 14 mm high LED display
- Prescaler
- 2 variable limit values
- Easy direct selection by 2 function keys
- Relay output with two change-over contacts
- Connection by plug-in screw terminals
- Chain value or absolute value indication
- Small compact design in DIN dimensions 48 x 96 mm
- Electronic value retention, non polluting – no battery
- NPN/PNP programming of inputs
- Optional with RS 232/RS 485 interface

Indication of infeed values, lengths, support- or machine positions, totalizing values etc. The coupling to the machine may be effected e. g. with an incremental shaft encoder from the wide and comprehensive Hengstler program of types RI 30 to RI 58.

6-digit LED display with 14 mm high digits, easy to read, decimal point can be programmed



- Section A:** shows the actual count value when in counting mode, and the changeable parameters when in programming mode.
- Section B:** LED indicators showing the active output signal, and in programming mode indicating the changeable parameter.

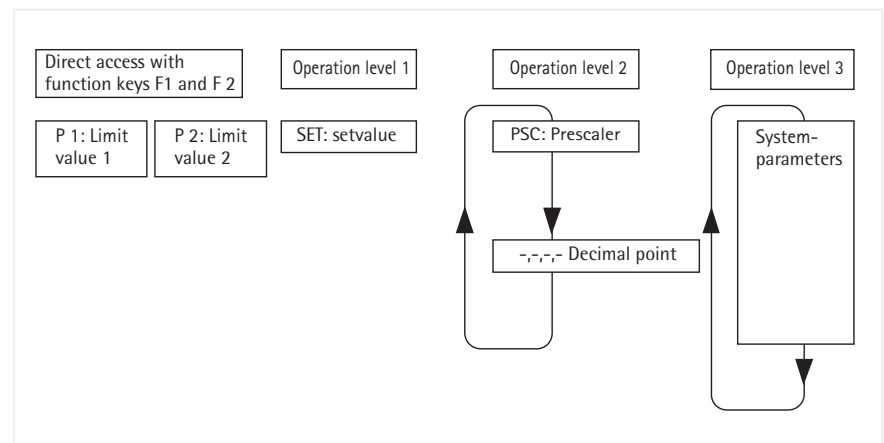

- Programming of signo 727 is possible by direct access and in the 3 operation levels.
- Direct access:** Limit value 1, Limit value 2 are set with the function keys F1, F2
 - Operation level 1:** Set value
 - Operation level 2:** Includes prescaler and decimal point
 - Operation level 3:** Includes system parameters, which are normally programmed during start-up procedure only.

Unauthorized programming of the signo 727 is prevented by a control input, which can lock the operation levels.

TECHNICAL DATA

Display	7-segment LED, 6 digits, suppression of leading zeros, programmable decimal point
Digit Height	14 mm
Power Supply Voltage U_b	12 ... 24 VDC or 115/230 VAC, depending on versions
Current Consumption	12 ... 24 VDC < 250 mA, 115/230 VAC < 60 mA
Sensor Supply	AC operation: 12 ... 24 VDC, DC operation: $U_b - 2 V$, $I_{max.} = 60 mA$
Data Retention	non-volatile memory > 10 years
Operating Temperature	0 ... 50 °C
Storage Temperature	-20 ... +70 °C
Electrical Connection	plug-in terminals
Mounting	with clamping frame
Protection Class (IEC 144)	front side IP 54, terminals IP 20
Noise Immunity EMC	severity according to IEC 801, part 2 + part 4
Vibrostability	10 m/s ² (10 ... 150 Hz) according to IEC 68-part 2-6
Shock Stability	100 m/s ² (18 ms) according to IEC 68-part 2-27
General Rating	according to VDE 0411, DIN 57411, protection class II

Inputs:

Switching Level	<2 V and >8 V, max. 40 VDC
Active Edge	positive when pnp input negative when npn input
Pulse Shape	any (square 1:1 at max. frequency)
Input Resistance	approx. 5 kΩ (static)
Count Input	with prescaler programmable 0.0005 bis 99.9999 – as phase discriminator input with single, double or quadruple evaluation – as differential input – as up/down input
Pulse Duration	12,5 μs (40 kHz), 17 ms (30 Hz)
Count Frequency max.	40 kHz or 30 Hz

Control Input:

Application Input 1	static, pulse duration > 3 ms
Display-Hold or Reset-enable, (programmable)	
Application Input 2	(Reset functions)
Reset and/or Chain-Reset, (programmable)	pulse duration > 3 ms or > 17 ms
Gate	static, pulse duration > 12 μs / > 17 ms
Keylock	static, pulse duration > 3 ms

Outputs:

Relay*	Out 1 and Out 2
Contact Type	changeover relay
Switching Voltage	max. 250 VAC / 30 VDC, min. 5 VAC/DC
Switching Current	max. 1A, min. 10 mA
Transistor*	Out 1 and Out 2, PNP, 10 mA

* for versions with limit value only

signo 727.1

Technical data

DIMENSIONAL DRAWING

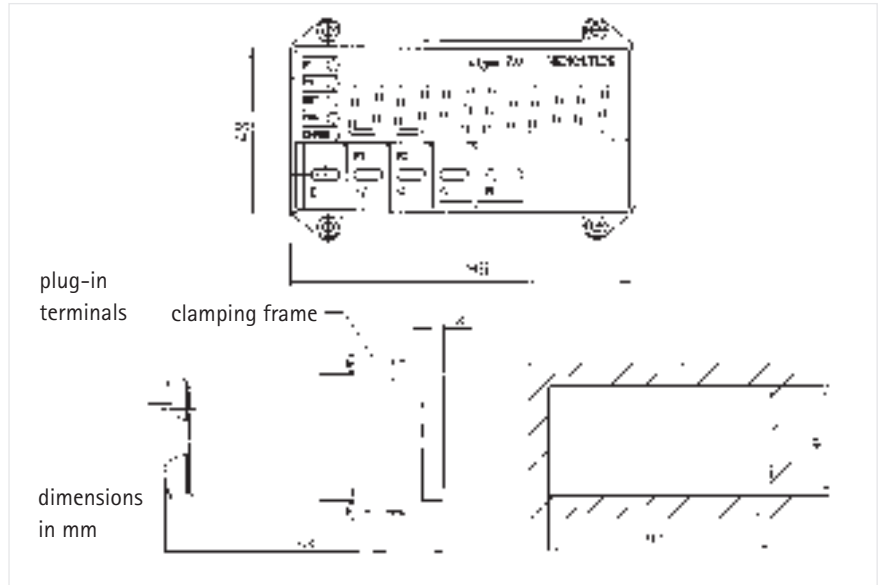

CONNECTION DIAGRAM

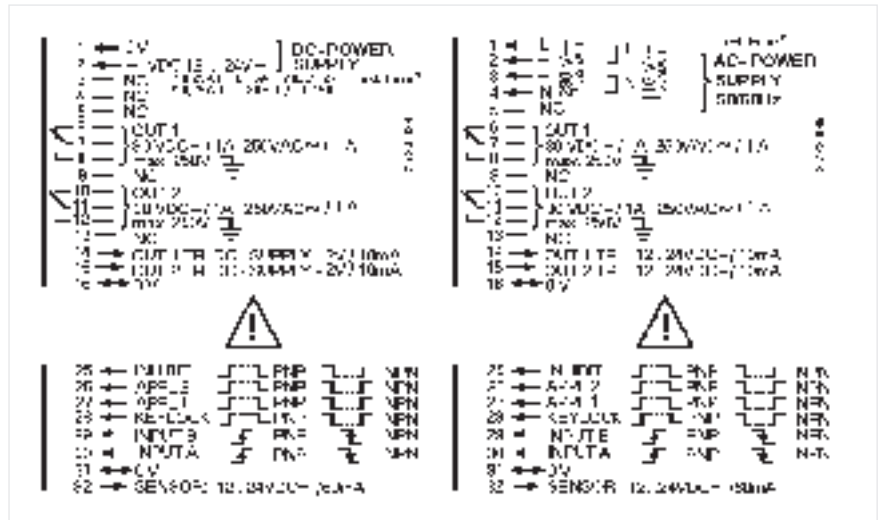

(here with Limit values)

ORDER INFORMATION

Type	Supply	Ordering code
signo 727 without limit values	12 ... 24 VDC	0 727 101
signo 727 without limit values	115/230 VAC	0 727 102
signo 727 with 2 limit values	12 ... 24 VDC	0 727 121
signo 727 with 2 limit values	115/230 VAC	0 727 122

This counter is available with several interfaces. See next pages.

Variable Preset Counter and Position Indicator with Interface RS 485 / RS 232

signo 723
signo 727



TECHNICAL DATA

- Large 6 digit LED display, 14 mm
- Up-/down counter, 6 digits, with different count modes and prescaler
- 2 preset values or 2 limit values
- Transistor outputs (PNP) and relay outputs (changeover contacts)
- Compact DIN 48 x 96 mm
- Easy manual operation with function keys
- Interface: RS 485 or RS 232

Power Supply Voltage	12...24 VDC or 115/230 VAC
Sensor Supply	AC-operation: 12...24 VDC, DC-operation: Vop=2V, I _{max.} = 60 mA

Inputs:

Switching Level	< 2 V and > 8 V, max. 40 VDC
Active Edge	positive PNP or negative NPN programmable
Count Input	with prescaler programmable 0.0005 ... 99.9999 - as phase discriminator input with single, double or quadruple evaluation - as differential input - as up/down input
Count Frequency max.	40 kHz or 30 Hz
Control Inputs	Reset, Gate, Hold and Keylock

Outputs:

Relay	Out 1 and Out 2 with changeover contact, 1 A, 250 VAC/30 VDC
Transistor	Out 1 and Out 2 with PNP-Output, 10 mA
maximum length	15 m

Input R x D

typical input resistance	5 kOhm
max input voltage	30 V

Input T x D

output voltage	8 V
output current max.	20 mA

Terminals A and B

typical input resistance	12 kOhm
max input voltage	- 7 .. + 12 V
output level	High: 3.5 V, Low: 1.3 V
output current max.	60 mA
maximum bus length	2000 m
data transfer rate	1200, 2400, 4800 Baud
data format	7 bits, even parity 8 bits, no parity
stop bits	1
protocol	Hengstler TP3 or ASCII (depending on version)

For further technical information please refer to the pages describing signo 723.1 and signo 727.1

RS 232

RS 485

Protocol

signo 723 signo 727

DIMENSIONS

Technical data

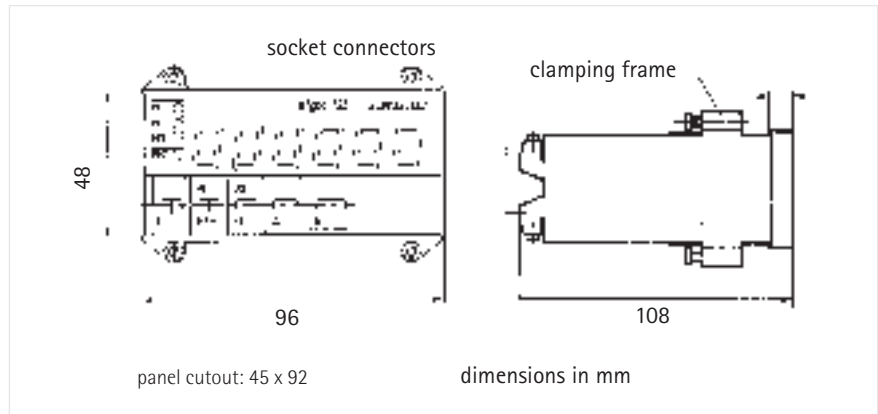

CONNECTION DIAGRAM

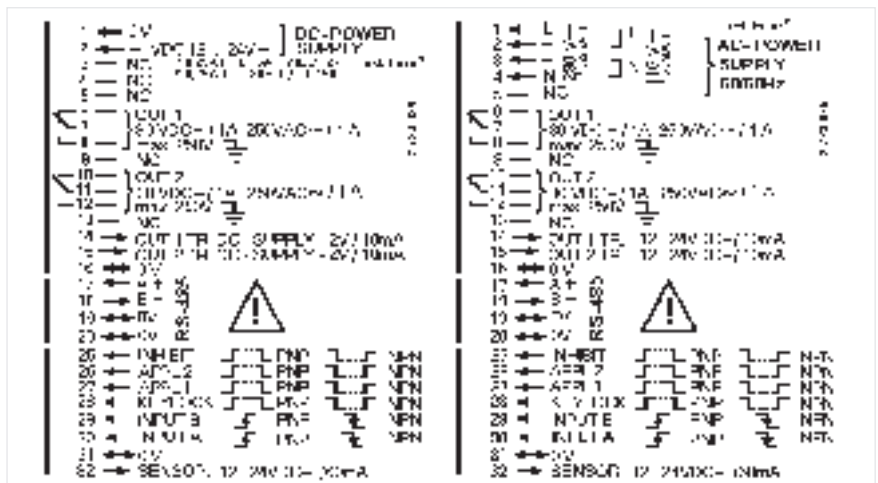

(here with interface RS 485)

PRINTER PROTOCOL FOR 723.1

Protocol	Standard ASCII
Baudrate	1200, 2400, 4800 Baud
Data format	7 Bits, even Parity, 1 Stop bit 8 Bits, no Parity, 1 Stop bit
Line and Form Feeds	programmable before and after printout
Cutter Control	programmable

PRINT MASKS

The counter allows for the programming of 5 different print masks	
Mask 0	only Count Value
Mask 1	Counters: <value>
Mask 2	Counter: <value>
Mask 3	Counter: <value> Preset1: <value> Preset2: <value> Set: <value> Prescaler: <value>
Mask 5	Length: <value> m

Technical data

signo 723
signo 727

ORDER INFORMATION

Counter

Version with interface		12...24 VDC	115/230 VAC
signo 723 Printersoftware RS232		0 723 150M1	0 723 151M1
signo 723 TP3 Protocol	RS232	0 723 150M3	0 723 151M3
	RS485	0 723 160M3	0 723 161M3
signo 727 TP3 Protocol	RS232	0 727 150M3	0 727 151M3
	RS485	0 727 160M3	0 727 161M3

Counter with time counter

signo 723 TP3 Protocol	RS485	0 723 125	0 723 126
------------------------	-------	-----------	-----------

PC-driversoftware for TP3 Protocol

Windows 95 / NT / 2000	0 723 167
------------------------	-----------

RTC Converter RS 485 / RS 232

RTC	0 723 169
Plug-in power supply for RTC	3 560 032
Connection cable RTC-PC (RS 232), 5 m	1 723 055

RTC



DIMENSIONS

CONNECTION DIAGRAMS

Remote Terminal Converter

The RTC is needed if more than one counter is to be connected to the PC or if the distance between the machine and the PC is longer than 15 m.

- up to 31 counters can be connected to the RTC via RS 485 bus
- Connection RTC - PC is a standard RS 232
- optimally tuned for operation with the Hengstler Software HTS (Hengstler Terminal Server)
- Power supply 12..24 VDC or 12..18 VAC, max. 2 VA (plug-in power supply available as accessory)

width 115 mm / height 38 mm / depth 165 mm

Connector ST 1

pin	signal
1	AC/DC
2	Earth
3	AC/DC

Connector ST 3

pin	signal
1.3	RS 485 A +
2.4	RS 485 B -
5	Earth

Connector ST 2

pin	signal	description
1	DCD	Carrier Detect
2	RXD	Receive Data
3	TXD	Transmit Data
4	DTR	Data Terminal Ready
5	GND	Signal Ground
6	DSR	Data Set Ready
7	RTS	Request To Send
8	CTS	Clear To Send
9	RI	Ring Indicator

signo 723
signo 727



EXAMPLE

```
' Logical counter address
Const CounterAddress = 25
' registers of a counter
Const CounterValue = 0
Const Preset1 = 1
Const Preset2 = 2
Const Chain = 3
```

Windows Software HTS for Counters

- Guided Setup
- A program group and start icon are created automatically
- Setup registers the OLE attributes of HTS in the Windows registry
- DDE- and OLE Server

Reading and writing a counter from within MS Excel:

```
' read counter and insert result in table 1
Sub Read_Counter()
    Set Hts = GetObject(Class:="Hengstler.TerminalServer.10")
    Result = Hts.ReadRegister(CounterAddress; CounterValue)
    Sheets(„Table1“).Cells(6; 2).Value= Result
Ende Sub

Sub Write_Counter()
    Data = Sheets(„Table1“).Cells(2; 2).Value
    Set Hts = HoleObject(Class:="Hengstler.TerminalServer.10")
    Result = Hts.WriteRegister(CounterAddress; CounterValue; Data)
Ende Sub
```

Position Indicator signo 727 SSI for Absolute Encoder Connection



- large, 6-digit, 14 mm high LED display
- predetermined offset
- 2 variable limit values
- easy direct selection by 2 function keys
- relay outputs with change-over contacts
- chain value or absolute value indication
- npn/pnp programming of inputs
- synchronous/serial Interface

APPLICATION FIELDS

Indication of infeed values, lengths, support- or machine positions, totaling values etc.

The coupling to the machine may be done with an absolute encoder with SSI-Interface from the wide and comprehensive Hengstler program of types RA 58.

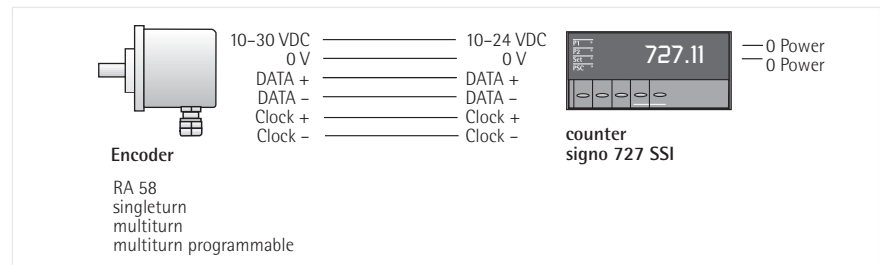

DISPLAY



Section A: shows the actual count value when in counting mode, and the changeable parameters when in programming mode.

Section B: LED indicators showing the active output signal, and in programming mode indicating the changeable parameter.

PROGRAMMING

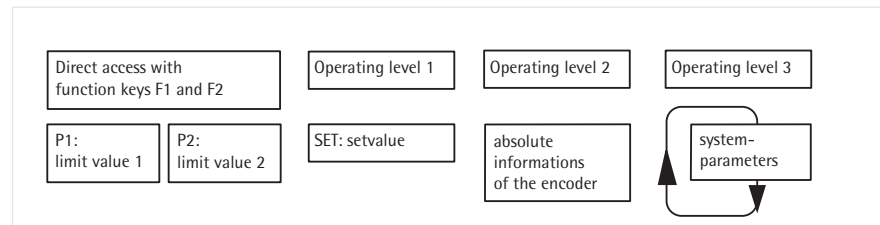

Programming of signo 727 is possible by direct access and in the 3 operating levels

Direct access: Limit values are set with the function keys F1, F2

Operating level 1: Set value

Operating level 2: Includes absolute informations of the encoder

Operating level 3: Includes system parameters, which are normally programmed during start-up procedure only.

Unauthorized programming of the signo 727 is prevented by a control input, which can lock the operating levels.

signo 727 SSI

TECHNICAL DATA

Technical data

Display	LED, indication value/preselection 6 digits, suppression of leading zeros, programmable decimal point, minus sign
Digit Height	14 mm
Power Supply Voltage U_b	12...24 VDC or 115/230 VAC, depending on version
Current Consumption	12...24 VDC < 250 mA, 115/230 VAC < 60 mA
Sensor Supply	AC operation 12...24 VDC, DC operation $U_B - 2 V$, $I_{max} . = 60 mA$
Data Retention	non-volatile memory > 10 years
Operating Temperature	0...50 °C
Storage Temperature	-20...+70° C
Electrical Connection	plug-in terminals
Mounting	with clamping frame
Protection Class (IEC 144)	front side IP 54, terminals IP 20
Noise Immunity EMC	severity 3 according to IEC 801, part 2 + part 4
Vibro Stability	10 m/s \approx (10...150 Hz) according to IEC 68-part 2-6
Shock Stability	100 m/s \approx (18 ms) according to IEC 68-part 2-27
General Rating	according to VDE 0411, DIN 57411, protection class II

Inputs:

SSI Data +

SSI Data -

Baud rate: ca. 100 kHz

Control Input:

Application Input 1 static

Display hold,

Reset or Chain Reset
(programmable)

Keylock static

Outputs:

SSI Clock +

SSI Clock -

Relay* Out 1 and Out 2

Contact Type changeover relay

Switching Voltage max. 250 VAC/30 VDC, mind 5 VAC/DC

Switching Current max. 1A, min. 10 mA

Transistor* Out 1 and Out 2, PNP, 10 mA

* for versions with limit value only

DIMENSIONAL DRAWING

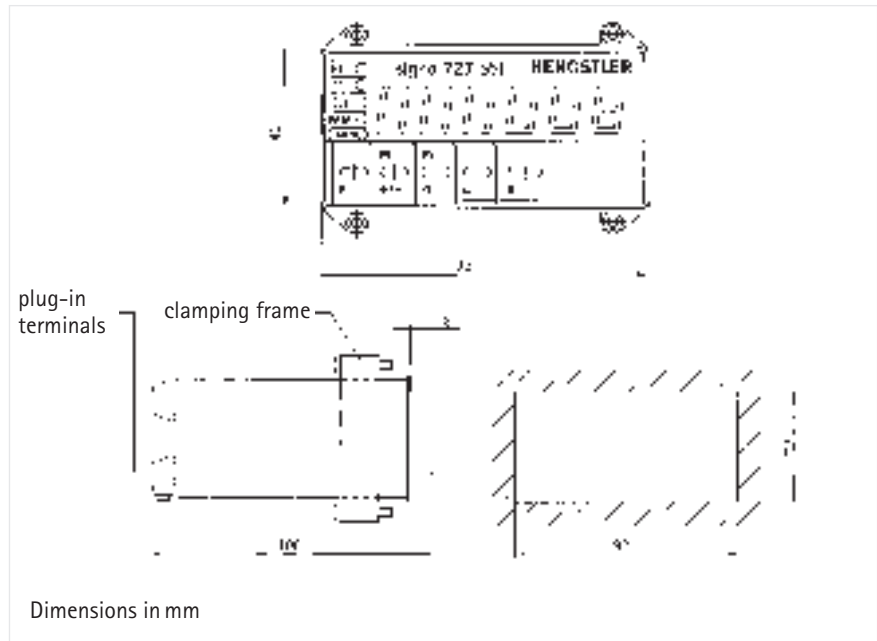

CONNECTION DIAGRAM

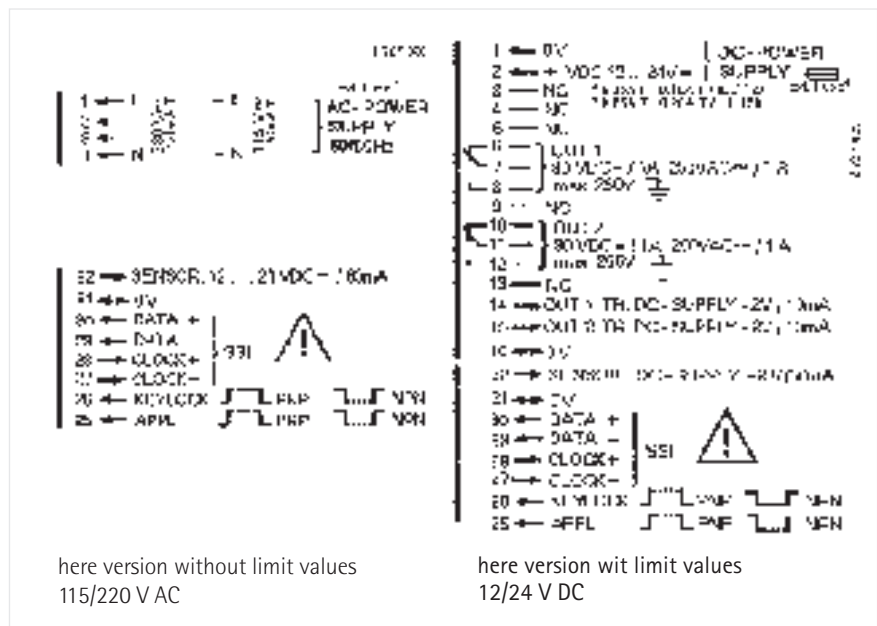

ORDER INFORMATION

Type	absolute encoder connection	Power supply	Ordering code
signo 727 without limit values	SSI	12...24 VDC	0 727 111
signo 727 without limit values	SSI	115/230 VAC	0 727 112
signo 727 with 2 limit values	SSI	12...24 VDC	0 727 131
signo 727 with 2 limit values	SSI	115/230 VAC	0 727 132

Do not use absolute encoder with cut Gray Excess Code (e. g. 360 or 720)
 Maximum Encoder resolution: 12 bits (Singleturn) and
 24 bits (Multiturn 12 + 12 bits)

Position Indicators

Notes