

Encoder Basics

GENERAL INFORMATION

Incremental encoders are sensors capable of generating signals in response to **rotary movement**. In conjunction with mechanical conversion devices, such as rack-and-pinions, measuring wheels or spindles, incremental shaft encoders can also be used to measure **linear movement**. The shaft encoder generates a signal for each incremental change in position.

With the **optical transformation**, a line-coded disc made of metal, plastic or glass and positioned on a rotary bearing interrupts the infra red light ray emitted by gallium arsenid sender diode. The number of lines determines the resolution, i.e. the measuring points within a revolution. The interruptions of the light ray are sensed by the receptor element and electronically processed. The information is then made available as a rectangular signal at the encoder output.

Output Signals of Incremental Encoders

OUTPUT SIGNALS

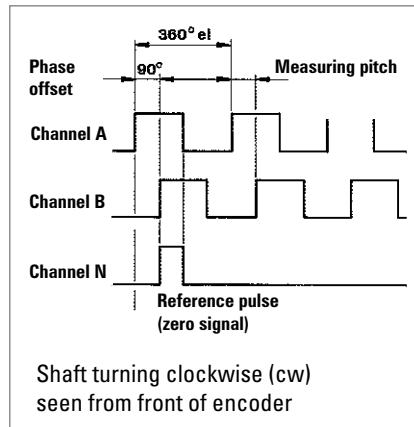

The shaft encoders supply two square wave pulses offset by 90° A and B, and a reference pulse N (zero signal) as well.

In order to suppress spurious pulses, certain output circuits (RS 422 and push-pull) generate inverted signals (\bar{A} , \bar{B} , \bar{N}), such as in models RI 30, RI 36, RI 58, RI 58-H, RI 76-TD and RI 58-D.

The measuring pitch is defined as the value of the distance between two pulse edges of A and B.

EVALUATION

The resolution of a two-channel shaft encoder can be doubled or quadrupled in the subsequent circuitry.

This enables the resolution of a two-channel encoder with 2500 lines per rev. to be increased electronically to 5,000 or 10,000 pulses per revolution (see diagram below).

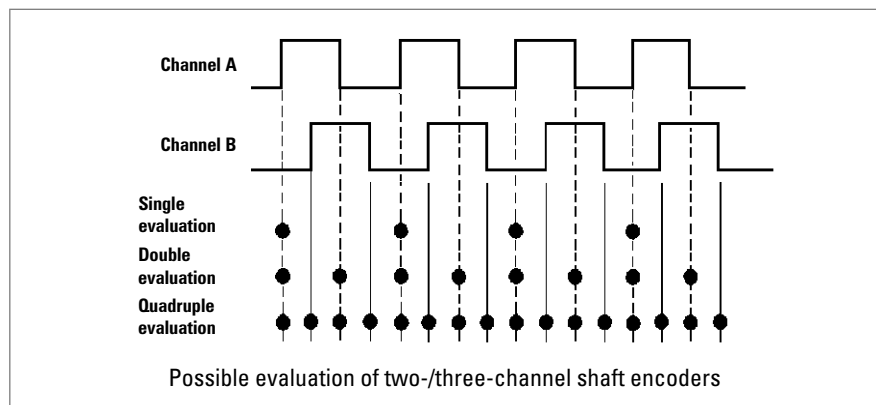

Encoder Basics

Maximum Speed, Protection Class

SPEED

The maximum permissible speed of a shaft encoder is derived from:

- the **mechanically permissible r.p.m.**,
- the minimum permissible **pulse-edge spacing** of the square-wave output signals of the shaft encoder for the subsequent circuitry, which depends on the tolerance of the phase offset,
- the **functional speed**, which is limited by the pulse frequency.

The mechanically permissible r.p.m. is specified for each shaft encoder among the mechanical characteristics.

In general, the control circuitry does not permit less than a certain **minimum edge spacing** between the square-wave output signal pulses. The minimum pulse-edge spacing is specified for each model of shaft encoder among the electrical characteristics.

The **functional speed** of an encoder is obtained by the equation:

$$n_{\max} = f_{\max} \cdot 10^3 \cdot 60 / Z$$

n_{\max} = maximum functional speed [r.p.m.]

f_{\max} = maximum pulse frequency of shaft encoder, or input frequency of downstream circuitry [kHz]

Z = number of pulses of shaft encoder

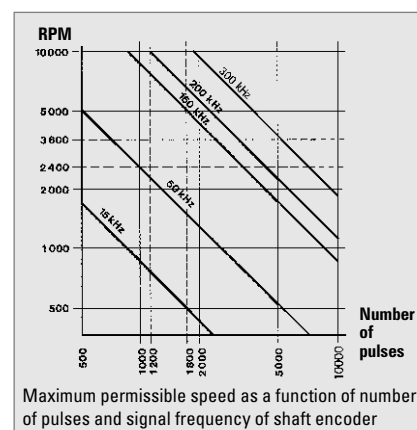

PROTECTION CLASS

All encoders of the industrial types RI 30, RI 36, RI 58, RI 58-H, RI 58-D, RA 70-I as well as the absolute encoders ACURO, comply with protection class IP65 according to EN 60529 and IEC 529, unless otherwise stated.

These specifications are valid for the housing and the cable output and also for plugged in socket connectors. The shaft input complies with protection class IP64. If however the encoder is mounted vertically, there must be no standing water present at the shaft input and the ball bearings.

In case the standard protection class IP64 is not sufficient for the shaft input, e.g. with vertical mounting of the encoder, the encoders must be protected by additional labyrinth or pot-type seals.

On request our encoders are also available with protection class IP67 for the shaft input and for the housing.

Encoder Basics

Examples of Flange Mounting

FLANGE TYPE OVERVIEW

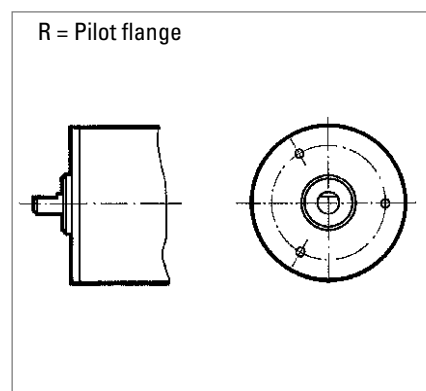
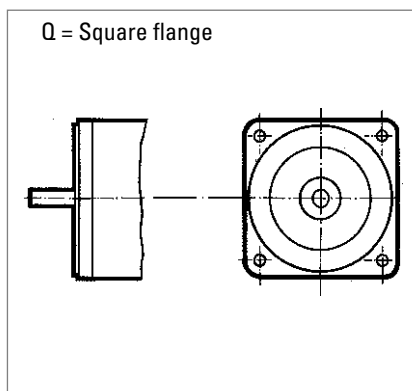
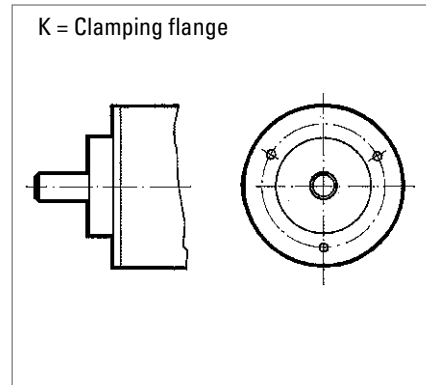
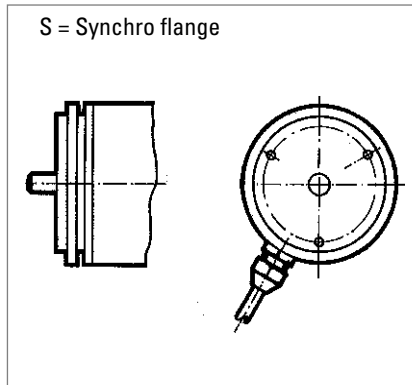

SHAFT ENCODERS WITH CLAMPING FLANGE

The shaft encoders with a clamping flange can be installed in following ways:

- by means of various flange adapters (see "Accessories"),
- by means of the clamping flange itself,
- by means of the fastening threads provided on the face,
- by means of an angle bracket (see "Accessories").

The encoder housing is centered by means of the clamping flange.

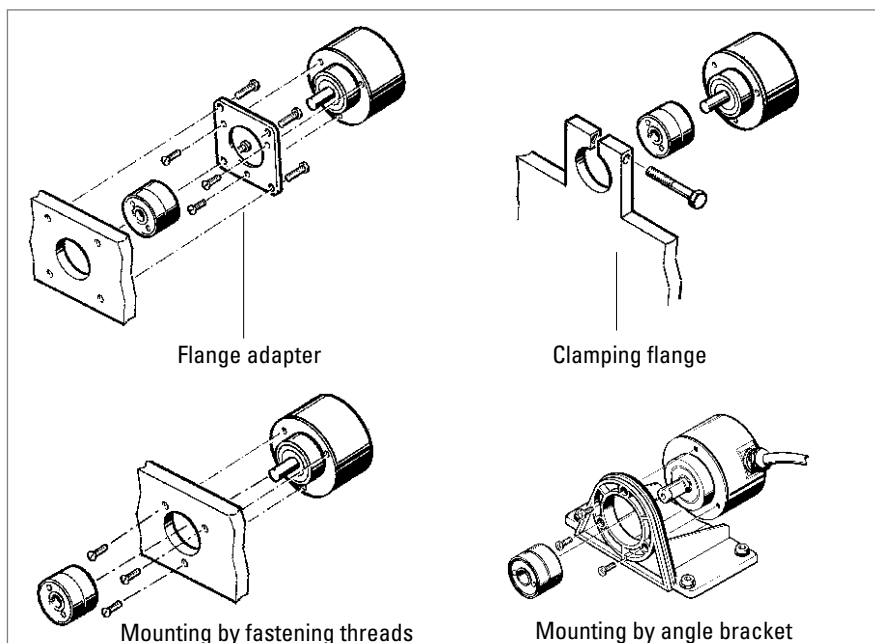

Encoder Basics

Examples of Flange Mounting

SHAFT ENCODERS WITH SYNCHRO FLANGE

The shaft encoders with synchro flange can be installed in two ways:

- by means of the synchro flange and three clamping eccentrics (see "Accessories"),
- by means of the fastening threads provided on the face.

The encoder is centered by means of the centering collar on the flange.

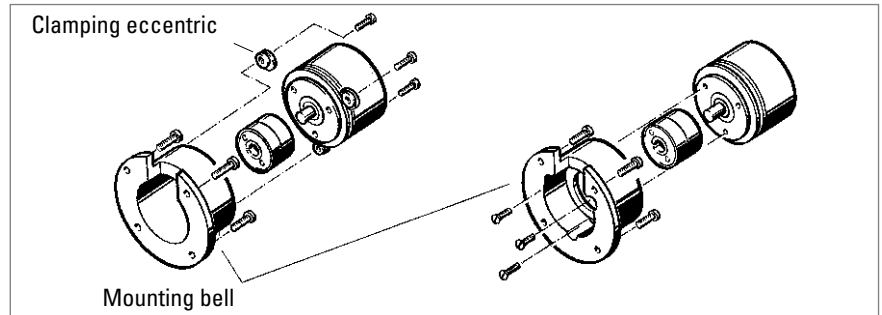

SHAFT ENCODERS WITH SQUARE FLANGE

The shaft encoders with square flange can be installed in two ways:

- by means of the fastening threads provided on the face,
- by means of an angle bracket.

The encoder is centered by means of the centering collar on the flange.

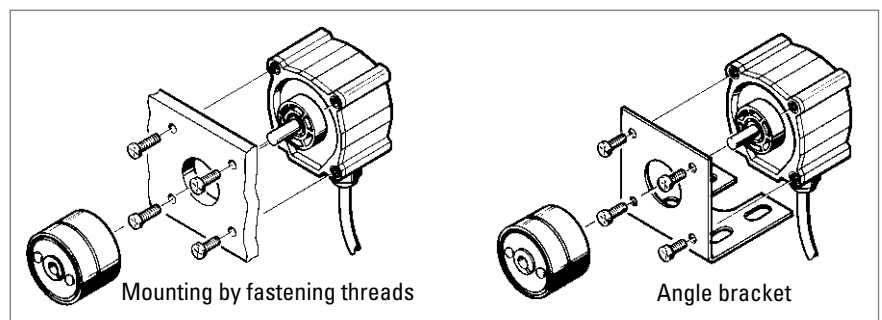

SHAFT ENCODERS WITH PILOT FLANGE

The shaft encoders with pilot flange can be installed in two ways:

- by means of the fastening threads provided on the face,
- by means of an angle bracket.

The encoder is centered by means of the centering collar on the flange.

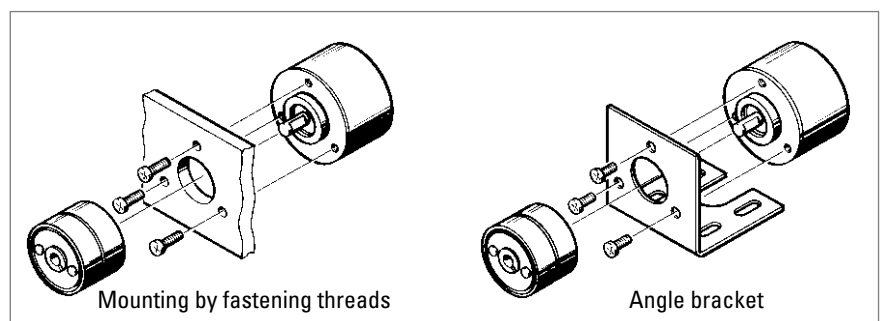

Encoder Basics

Examples of Flange Mounting

SHAFT ENCODERS WITH HOLLOW SHAFT (RI 58-D/G)

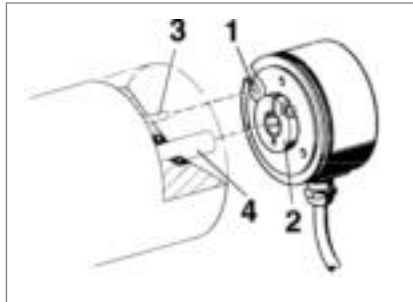

Mounting of version F, D (Clamping shaft)

- 1 Torque support
- 2 Clamping ring with cross-recess screw
- 3 Straight pin
- 4 Actuating shaft

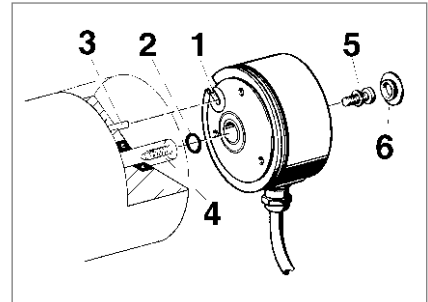

Mounting of version E (Blind shaft)

- 1 Torque support
- 2 O-ring
- 3 Straight pin
- 4 Actuating shaft with threaded bore
- 5 M4-screw with spring washer
- 6 Cap

SHAFT ENCODERS WITH HOLLOW SHAFT (RI 76, RI 80-E, AC110)

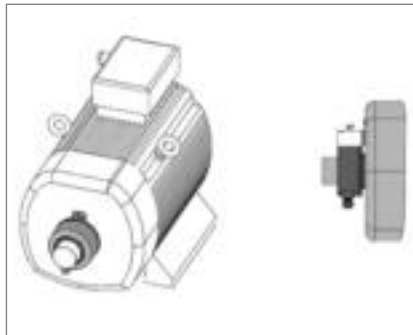

MOTOR SHAFT ENCODERS WITH HOLLOW SHAFT (E9, M9)

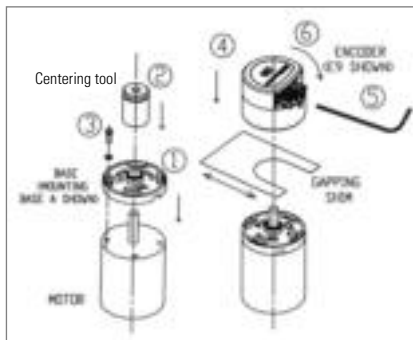

1. Place the base plate of encoder onto the motor rear end plate.
2. Install centering tool on motor shaft to center the base plate with respect to the shaft.
3. Install hardware supplied and tighten to secure the base plate. Remove centering tool.
4. Position and mount the encoder housing onto the base plate with its 3x120' bayonet snaps in their corresponding slots on the base plate. Slide the gapping shim between the base plate and the encoder from the side opposite the connector.
5. Place the hex wrench into the codewheel set screw. Tighten the set screw while pushing the codewheel down toward the gapping shim with the wrench.
6. Remove the gapping shim, push down and twist the encoder 30° clockwise to lock it in place.

SHAFT ENCODERS WITH SOLID SHAFT

Connection of solid-shaft encoders to the shaft is by means of a coupling. The coupling compensates for axial movements and lack of alignment between the shaft encoder and the drive shaft, thus preventing excessive bearing loads on the encoder shaft. For further details please refer to chapter "Accessories".

Basics of Incremental Encoders

Outputs - RS 422 - TTL

OUTPUT CIRCUIT

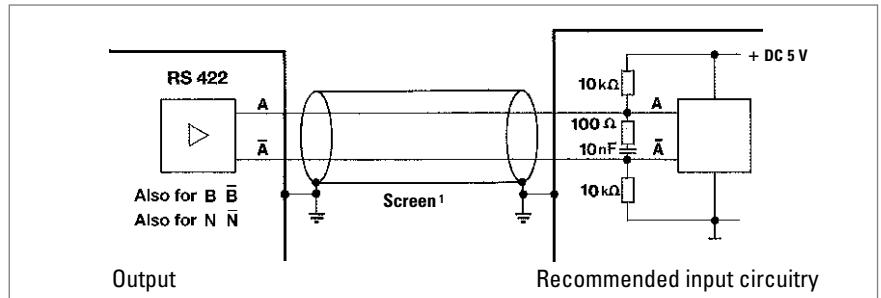

¹ Cable screen:

- not existing for RI 32, 38, 42,
- connected to encoder housing for RI 30, 36, 58, 59, 76 and RA 70

TECHNICAL DATA

Code letter	R = RS 422 + Alarm ³ (with $U_B = DC 5/10 - 30 V$) T = RS 422 + Sense ⁴ (only with $U_B = DC 5 V$)
Output signals shaft turning clockwise (cw) seen from front of encoder	<p>Square wave pulses (TTL) for channels A, B, N and their inverted signals \bar{A}, \bar{B}, \bar{N}</p>
Delay times at 1,5 m cable	<p>$\leq 100 \text{ ns} \leq 100 \text{ ns}$</p>
Pulse shape	
Pulse duty factor	1:1
Phasing	$90^\circ \pm 25^\circ$ electrical
Symmetry	$180^\circ \pm 25^\circ$ electrical
Max. Output frequency	300 kHz
Output voltage	DC 0 ... +5 V ²
Output level	$H \geq DC 2,5 V / L \leq DC 0,5 V$ (TTL-level)
Output load max.	$\pm 30 \text{ mA}$
Short circuit protection	with $U_B = DC 5 V$: only 1 channel at a time for max. 1 s (Standard RS 422-driver) with $U_B = DC 10 - 30 V$: short circuit proof for all channels due to integrated controller
Pole protection of U_B	with $U_B = DC 5 V$: no with bei $U_B = DC 10 - 30 V$: yes

¹ Distance A to B is at least $0,45 \mu s$ (at 300 kHz)

² also for $U_B = DC 10 - 30 V$

³ Description - see Outputs Alarm

⁴ Description - see Outputs Sense

CABLE LENGTH

depending on voltage and frequency (at 25 °C) ¹:

Length	RS 422
10 m	DC 5 V, 300 kHz
50 m	DC 5 V, 300 kHz
100 m	DC 5 V, 300 kHz

¹ with Hengstler accessory cables

Basics of Incremental Encoders

Outputs - Push-pull

OUTPUT CIRCUIT

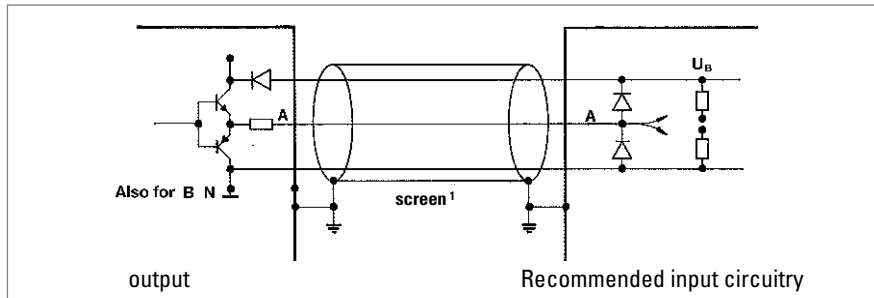

¹ Cable screen:

- not existing for RI 32, 38, 42
- Not connected to encoder housing for bei RI 41
- Connected to encoder housing for RI 30, 36, 58, 59, 76 and RA 70

TECHNICAL DATA

Code letter	K = push-pull, 10 mA with $U_B = DC 5 V$ or push-pull, 30 mA with $U_B = DC 10 - 30 V$ D = push-pull, 30 mA with $U_B = DC 5 V$		
Output signals shaft turning clockwise (cw) seen from front of encoder			
Delay times at 1,5 m cable	<ul style="list-style-type: none"> ■ $\leq 100 \text{ ns}$ (DC 5 V, push-pull D) ■ $\leq 250 \text{ ns}$ (DC 5 V, push-pull K) ■ $\leq 2 \mu\text{s}$ (DC 10 - 30 V, push-pull K) 		
Pulse shape			
Pulse duty factor	1:1		
Phasing	$90^\circ \pm 25^\circ$ electrical		
Symmetry	$180^\circ \pm 25^\circ$ electrical		
Max. Output frequency	300 kHz (see cable length)		
Output voltage	$0 \dots + U_B$		
Output level	K	K	D
	push-pull (DC 10 - 30 V)	push-pull (DC 5 V)	push-pull (DC 5 V)
	$H \geq U_B - 3V$	$H \geq 2,5 V$	$H \geq 2,5 V$
	$L \leq 2 V$	$L \leq 0,5 V$	$L \leq 0,5 V$
Output load max.	$\pm 30 \text{ mA}$	$\pm 10 \text{ mA}$	$\pm 30 \text{ mA}$
Short circuit protection	all channels	all channels	1 channel ²
Pole protection of U_B	yes	yes	no

¹ Distance A to B is at least $0,45 \mu\text{s}$ (at 300 kHz)

² only 1 channel at a time for max. 1 s

CABLE LENGTH

depending on voltage and frequency (at 25 °C) ¹ :			
Length	push-pull (K) DC 5 V, 10 mA	push-pull (D) DC 5 V, 30 mA	push-pull (K) DC 10 - 30 V, 30 mA
10 m	300 kHz	300 kHz	DC 12 V, 200 kHz DC 24 V, 200 kHz DC 30 V, 200 kHz
50 m		300 kHz	DC 12 V, 200 kHz DC 24 V, 200 kHz DC 30 V, 100 kHz
100 m		300 kHz	DC 12 V, 200 kHz DC 24 V, 100 kHz DC 30 V, 50 kHz

¹ with Hengstler accessory cables

Basics of Incremental Encoders

Outputs - Push-pull complementary

OUTPUT CIRCUIT

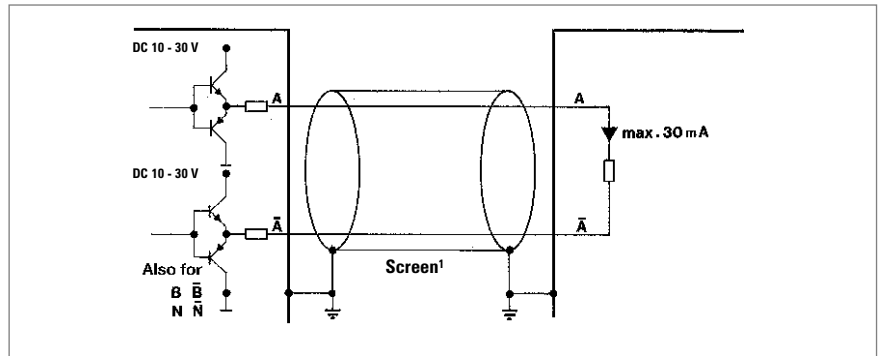

¹ cable screen connected with encoder housing

TECHNICAL DATA

Code letter	I = push-pull complementary (with $U_B = DC 10 - 30 V$)
Output signals shaft turning clockwise (cw) seen from front of encoder	<p>Square wave pulses (HTL) for channels A, B, N and their inverted signals \bar{A}, \bar{B}, \bar{N}</p>
Delay times at 1,5 m cable	<p>$\leq 250 \text{ ns}$ $\leq 250 \text{ ns}$</p>
Pulse shape	
Pulse duty factor	1:1
Phasing	$90^\circ \pm 25^\circ$ electrical
Symmetry	$180^\circ \pm 25^\circ$ electrical
Nax. output frequency	200 kHz (see cable length)
Output voltage	$0 \dots + U_B$
Output level	$H \geq U_B - 3V / L \leq 2V$
Output load max.	$\pm 30 \text{ mA}$
Short circuit protection	short circuit proof for all channels due to integrated controller
Pole protection of U_B	yes

¹ Distance from A to B is at least $0,7 \mu\text{s}$ (at 200 kHz)

CABLE LENGTH

depending on voltage and frequency (at 25°C) ¹ :	
Length	push-pull complementary
10 m	DC 12 V, 200 kHz
	DC 24 V, 200 kHz
	DC 30 V, 200 kHz
50 m	DC 12 V, 200 kHz
	DC 24 V, 50 kHz
	DC 30 V, 25 kHz
100 m	DC 12 V, 150 kHz
	DC 24 V, 25 kHz
	DC 30 V, 12 kHz

¹ with Hengstler accessory cables

Basics of Incremental Encoders

Outputs - Alarm

OUTPUT CIRCUIT

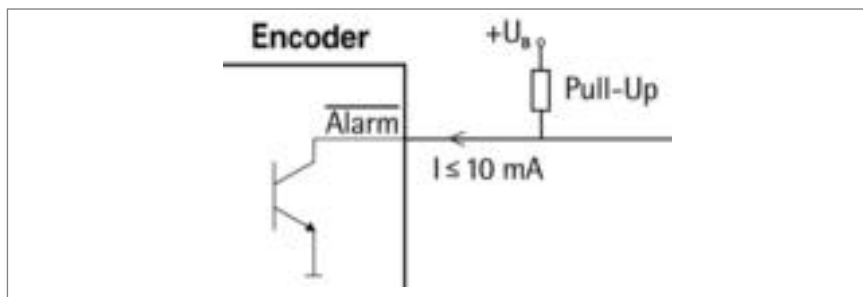

TECHNICAL DATA

Output	NPN - Open collector
Output load max.	5 mA / 24 V at $U_B = DC 5 V$ 5mA / 32 V at $U_B = DC 10- 30 V$
Output level	Output active (failure condition): $L \leq DC 0,7 V$ Output inactive: high impedance (if necessary: get H-level by an external pull-up resistor)
Malfunction indication time	$\geq 20 ms$

FUNCTION

The rotary encoders are equipped with an electronic monitoring system that reports potential malfunctions via a separate alarm output.

The alarm output can be used for selecting an optical display (LED; for circuit, see above) or the control system (SPC or similar).

Moreover, the alarm outputs of several encoders can be interconnected to a common "systems alarm" by means of a parallel connection. The following errors are indicated:

Category I	Category II	Category III
- damaged disks	- overtemperature	- voltage range $DC 1 V < U < DC 4 V$
- defective LED	- overload (e. g. due to short circuit)	- voltage drop on the supply lines
- contamination		

Category I malfunctions cannot be corrected; the encoder must be replaced.

Category II malfunctions are detected by means of a thermal monitoring unit in the electronic system. The alarm message is cleared after the cause of temperature increase has been removed.

Category III malfunctions indicate insufficient supply voltage. Also included in this category are transients in the supply voltage, e.g. due to electrostatic discharge, which may distort the output signals.

This is corrected by

- readjustment to the correct voltage
- eliminating the cause of disturbance, i.e. by careful arrangement of the cables.

Basics of Incremental Encoders

Outputs - Sense at 5 V RS 422 (T)

OUTPUT CIRCUIT

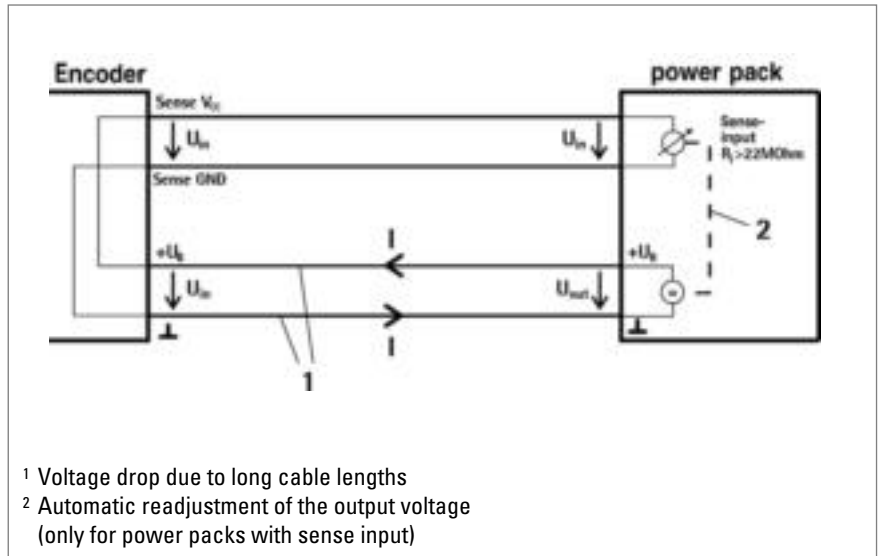

FUNCTION

The sense wires enable measuring of the actual encoder supply voltage (compensates for voltage drops due to supply current and cable resistance).

Due to the voltage drop in the cables and the voltage supply, the encoder input voltage U_{in} is less than the power pack output voltage U_{out} .

The present input voltage U_{in} is now output to the Sense V_{CC} and Sense GND cables and returns as data to the power pack.

The input resistance R_i on the power pack should amount to at least 22 M Ω so that no voltage drop occurs on these cables.

In case of power packs with sense input, it is now possible to readjust the output voltage U_{out} automatically.

Basics of Sine-Wave Encoders

GENERAL INFORMATION

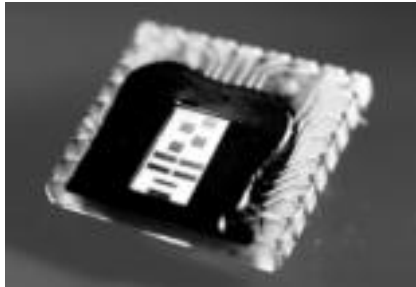

SINE-WAVE OPTOASIC TECHNOLOGY BURSTS THE LIMITS

With the introduction of the sine-wave encoder family, Hengstler has taken the opportunity to significantly rework its OptoAsic technology.

The best features have been maintained and new improvements have been introduced. One major feature that has been retained of course, is the high level of EMC reliability which we have achieved by integrating almost the complete encoder electronics into one component.

What is new is the integrated offset and amplitude control together with the in-chip optical system adjustment. In the past anybody wanting high quality, accurate sine-wave signals at low frequencies had to trade in this for bandwidth. We are now able to meet this apparently contradictory requirement with our in-built amplitude control. You can't fail to be convinced by a unit which delivers sine-wave signal with harmonic distortion better than 1% at low speed and 500 kHz max. frequency.

The advantages are crystal clear: If you need precision at slow speeds you no longer have to compromise your productivity because the encoder limits the maximum speed of your machine e.g. for tool changing processes. You can have both - accuracy and speed.

APPLICATIONS

Typical applications:

- Machine tools
- Printing machines
- Gearless elevators
- Drives

Basics of Sine-Wave Encoders

Signals

THE RIS58 SIGNALS

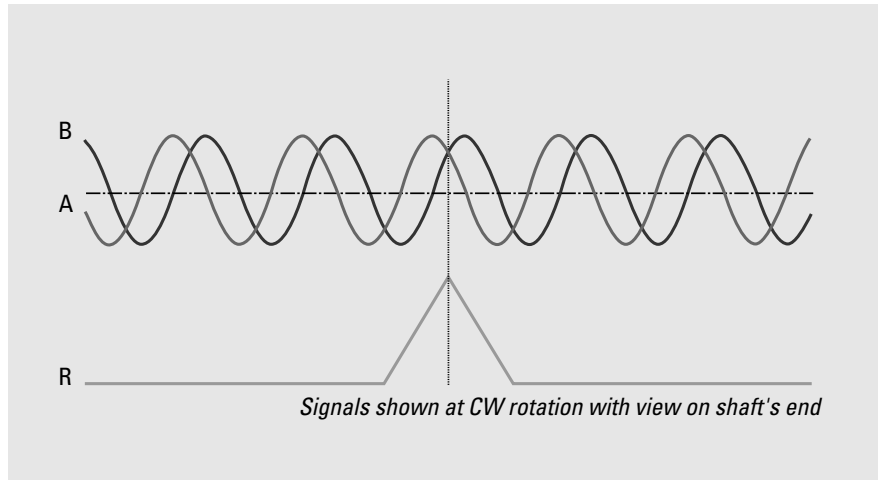

The incremental signals A and B and the zero signal R are differential voltage signals. The differential signal level is 1 V_{pp}. The zero signal appears once per revolution with a peak of 0.4 V and reaches its maximum value at the angle where the amplitudes of the A and B signals are equal. All signals have a DC-offset of 2.5 V.

THE RIS58 SIGNAL QUALITY

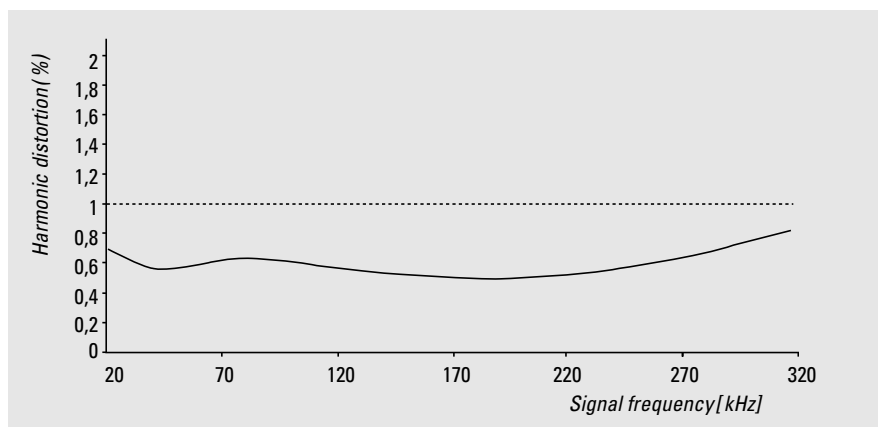

The quality of the servo loop is determined to a large extent by the absence of harmonics in the encoder's sinewave signals, particularly at low speed. In order to achieve high interpolation factors in the sequencing control, the incremental sine signals A and B are available with a harmonic distortion significantly under 1% throughout the specified temperature range. This delivers excellent synchronism and a high level of positional accuracy with servo axes.

Basics of Absolute Encoders ACURO

ABSOLUTE ENCODERS FOLLOW THE LATEST TREND: CHANGE EASILY TO ACURO

Absolute encoders save costs and provide enhanced safety - facts that are obviously important in complex installations and multi-axis machinery: Time-consuming reference runs after powering-up the supply voltage have become a thing of the past for absolute encoders. Hazardous conditions caused by reference runs (which are always necessary with incremental encoders) can be prevented right from the start. Absolute encoders - too large, too expensive?

A prejudice that is cleared up by ACURO. Even the multi turn version of ACURO is no larger than most incremental encoders and costs less than you would expect. And how about reliability? Due to their complexity, absolute encoders seem to be susceptible to faults. No problem with ACURO: once installed they will not cause trouble, due to the highest integration density and use of extremely reliable technologies to ensure safe and reliable long-term operation.

The platform concept

Hengstler's new ACURO absolute encoders feature innovative technology, simple operational and optimal functional safety. Their platform concept also allows especially compact dimensions with a modular design, which always ensures the right version for each individual application in the field of motor feedback and automation engineering. Equipped with the new open BiSS interface these encoders are a good and future oriented investment.

The mechanical construction of ACURO is rugged and precise. Double high-precision ball bearings guarantee reliable long-term operation even at speeds of up to 12000 rpm. ACURO is equipped with the commercially available mechanical interfaces, including solid shaft or hub shaft, synchro-flange or clamping flange.

ABSOLUTE ENCODERS ARE DIFFERENTIATED ACCORDING TO:

Singleturn version

1 revolution (= 360 °) is coded in n steps. After a rotation of over 360 ° the code is repeated.

Multiturn version

Apart from measuring 360 ° (1 revolution) further coded revolutions can be recorded e.g for applications in combination with lead screws or timing belts. Hengstler is using the principle of a mechanical memory (gearbox, which is unmatched in reliability and EMC).

Basics of Absolute Encoders ACURO

High-Tech Features in a Modular System

INNOVATIVE TECHNOLOGY

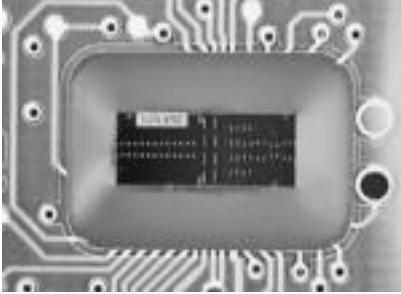

Hengstler's ACURO series comprises a complete range of absolute encoders, all in OPTOASIC technology. OPTOASIC units combine all required optical and electronic components in only one silicon chip.

This new technology is tailored to the user's needs and offers advantages previously unknown in the field:

- **High degree of reliability** due to differential scanning and single-step Gray code.
- **Fail-safe** due to the elimination of more than a hundred components
- **Long serviceable lifetime** due to state-of-the-art semiconductor technology-

- High degree of **electromagnetic compatibility** due to elimination of macroscopic low-current paths.

Our new absolute shaft encoders have an excellent price/performance ratio. As a further feature the encoders are fully backward compatible due to identical mounting flanges and electrical interfaces.

This makes it easy for the user to switch from incremental to absolute shaft encoders.

PROGRAMMABLE ABSOLUTE SHAFT ENCODERS

All essential parameters are user-programmable.

Additional advantages are uncomplicated subsequent data processing, electronic adjustment and add-on optimization of mechanical systems which are subject to tolerances.

Furthermore, storage and maintenance are more cost-efficient: the same encoder may be used for a variety of applications and assigned to its task at the place of installation.

APPLICATIONS

The new encoders are, for example, perfectly suited to determine angular positions in automated systems with reliable and precise operation.

Absolute encoding eliminates the need for a reference run after interruptions (such as power failures).

ACURO is the right match for a wide range of applications - from medical technology, elevators, all printing, paper processing or metal-processing machinery, such as presses and saws, right through to highly-dynamic drives.

INTERFACES



Of course, the user has a selection of the most advanced interface technology available:

- Tristate parallel drivers
The symmetrical push-pull drivers are fully short circuit proof, overload protected and polarity protected in a range from 10 to 30 V.
Parallel bus systems are easy to realize. So you save in cabling expenses.
- CAN
Bus specifications according to CAN High-Speed ISO/DIS 11898 for transfer rates up to 1 MBaud.
- Suconet K1
Klöckner-Moeller 2 wire fieldbus
- DeviceNet
 - Based on CAN layer 2 (data link layer)
 - Up to 64 nodes and 500 KBAud speed
 - Configuration via network

- INTERBUS
Interface including the potential-free power supply is already integrated in the housing with a diameter of only 58 mm.

- SSI
The encoders can also be supplied with synchronous-serial interface (SSI) which is available worldwide.
This allows trouble-free connection to commercial processing components.

- Profibus DP
Protocol according to encoder profile class C2 (programmable)

- BiSS
 - bidirectional and fully digital
 - synchronous serial data
 - licence-free
 - up to 8 slaves per master

Basics of Absolute Encoders ACURO

Open Digitale Sensor Interface (BiSS)

GENERAL INFORMATION

The bidirectional digital sensor interface BiSS safeguards communication between position encoders or measuring devices and industrial controls, such as a drive control, for example, and if necessary can transmit measurement values from up to 8 sensors simultaneously.

For 1 to 8 subscribers the interface master provides a clock signal for the simultaneous capture of all position data and for the synchronous-serial data transmission which

follows on from this. Just four unidirectional RS422 data lines are required; the slave electronics, kept to an absolute minimum, are incorporated on the sensor ICs.

When the master sends a clock pulse on line MA, the slave answers directly on return line SL with the recorded position data. Commands and parameters can be swapped on a PWM pulse form; this is, however, not necessary to start the BiSS protocol.

TRANSFER SEQUENCE

With each data cycle the master learns and compensates for line delays, thus permitting clock rates of up to 10 Mbit/s even for cable lengths of up to 100 m. Changes in line conditions which occur during cable drag, for example, are corrected. The precision of synchronization among several position encoders along various axes is less than 1 microsecond; the master also makes the signal delay it has recorded accessible to the control unit, allowing further optimization.

The BiSS protocol classifies each subscriber in the following data sections: sensor data, register data. These data sections have various setups with regard to access and transmission performance so that a number of different sensor applications are

catered for. Bidirectional parameter communication for device configuration - also applicable to what are known as OEM parameters - is usually consigned to the register data section, with rapidly changing angle data being assigned to the sensor data section.

Control cycle times of less than 100 μ s are thus not a problem, even for data words of up to 64 bits in length. There is enough room in the protocol for redundancy; this space is normally used to implement a CRC (cyclic redundancy check). Framed by just one start and one stop bit, the sensor data is transmitted at the best-possible core data rate. Permanent monitoring of the position and operation of the encoder is possible without interfering with the control cycle.

Block diagram of a BiSS Master-Slave configuration

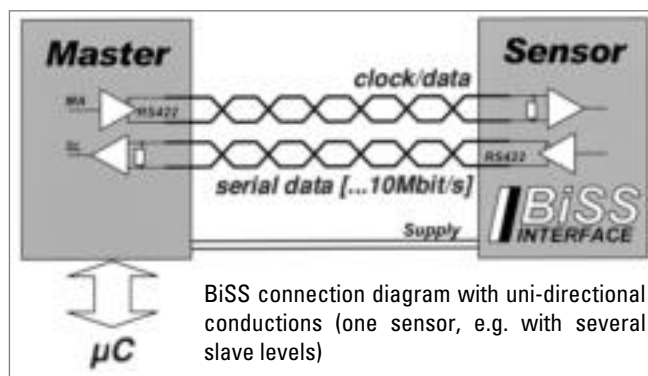

Configuration

Specific product developments of individual users are not restricted or made unnecessarily expensive by a compulsory compatibility.

A BiSS subscriber is described with just a few parameters and the XML-descriptive file included with the delivery simplifies start up of the control system.

i For further information see: www.biss-interface.com

Basics of Absolute Encoders ACURO

Synchronous-Serial Interface (SSI)

GENERAL INFORMATION

In many cases, absolute shaft encoders are subject to severe mechanical stresses and to electrical and magnetic fields that contaminate the site.

Therefore, special design measures are needed to combat dirt, dust and liquids in industrial environments.

Our absolute shaft encoders are of state-of-the-art rugged mechanical construction, and the electronic components are very compact.

A main consideration for immunity to interference is the data transfer from the shaft encoder to the control system. The control system must be able to read the readings from the shaft encoder without errors. Under no circumstances should undefined data be transmitted, for example at the changeover point.

The major differences between the concept of synchronous-serial data transfer for absolute shaft encoders described here and parallel and asynchronous serial forms of data transfer are:

- less electronic components
- less cabling for data transfer
- the same interface hardware, regardless of the absolute shaft encoder's resolution (word length)
- electrical insulation of the shaft encoder from the control system by optocouplers
- open-circuit monitoring by constant current
- data transfer rates up to 1.5 megabits per second (depending on the length of line)
- ring-register operating possible.

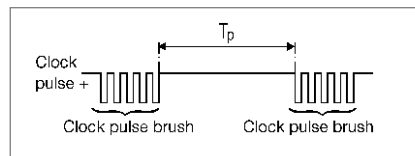

TRANSFER SEQUENCE

For correct transfer of the data a defined number of pulses (clock pulse brush) must be applied to the clock input of the absolute shaft encoder. Next, a pause T_p must be observed. As long as no clock signal is applied to the shaft encoder, its internal parallel/serial shift register remains switched to parallel. The data change continuously, corresponding to the current position of the shaft encoder's shaft.

As soon as a clock pulse brush is applied to the clock input again, the instantaneous angular data is recorded.

The first shift of the clock signal from high to low ① actuates the shaft encoder's internal retriggerable mono-stable element, whose storage time t_m must be greater than the clock signal's period T .

The output of the monostable element controls the parallel/serial register via terminal P/S (parallel/serial).

Block diagram of an absolute shaft encoder

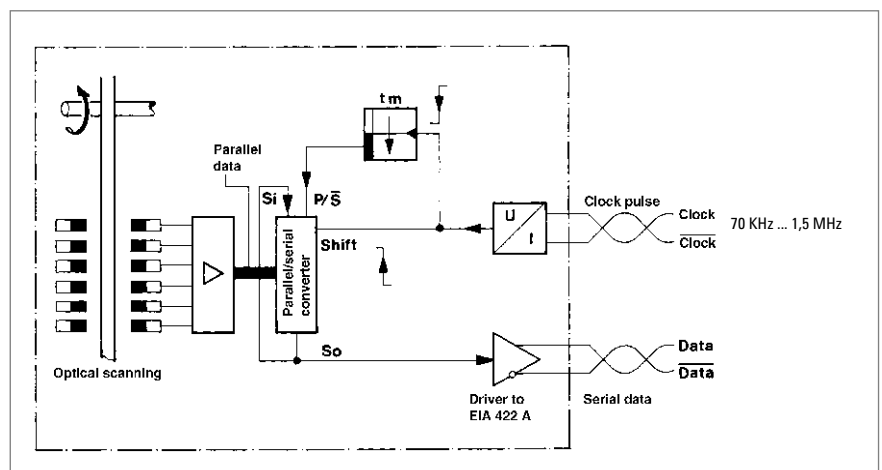

Basics of Absolute Encoders ACURO

Synchronous-Serial Interface (SSI)

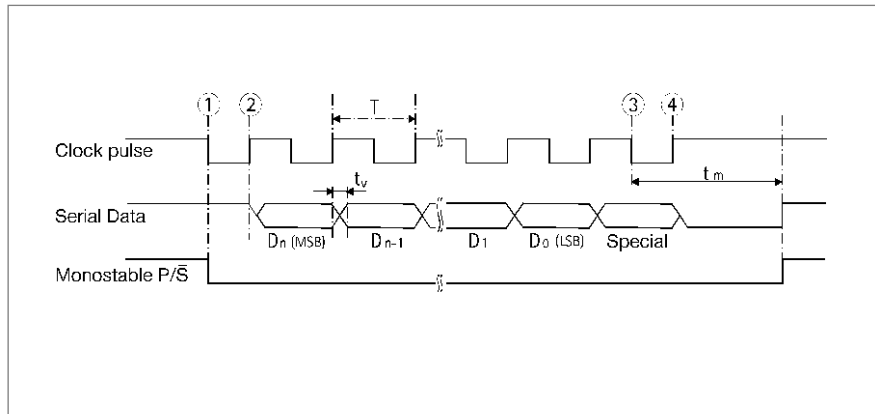

T = clock pulse period

t_m = storage time of monostable element

t_m ranging from 10 μ s to 30 μ s

t_v = 100 ns

The number of clock pulses necessary for data transfer is independent of the resolution of the absolute shaft encoder.

The clock signal can be interrupted at any point, or continued in ring-register mode for repeated polling.

With the first shift of the clock signal from low to high ② the most significant bit (MSB) of the angular data is applied to the shaft encoder's serial output.

With each succeeding rising edge, the next less significant bit is shifted to the data output.

After transmission of the least significant bit (LSB) the Alarm bit or other special bits are transferred, depending on configuration. Then the data line switches to low ③ until the time t_m has passed.

A further transfer of data cannot be started until the data line switches to high ④ again. If the clock pulse sequence is not interrupted at point ③, the ring-register mode is activated automatically. This means that the data stored at the first clock pulse transition ① are returned to the serial input S_i via the terminal S_0 . As long as the clock pulse is not interrupted at ③, the data can be read out as often as wanted (multiple transfer).

Basics of Absolute Encoders ACURO

Synchronous-Serial Interface (SSI)

Input circuit

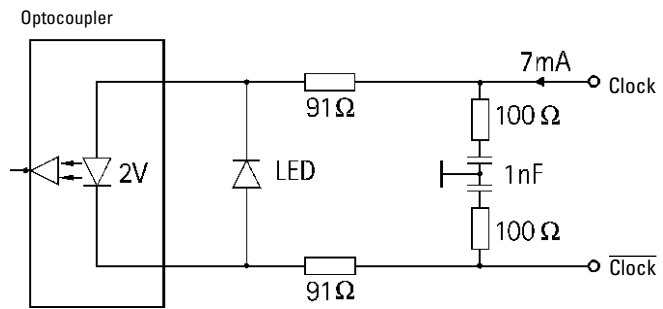

Output circuit

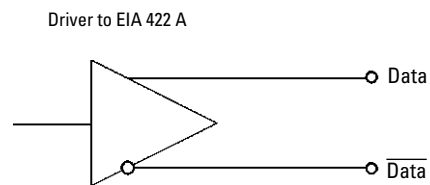

RECOMMENDED DATA TRANSMISSION RATE

The maximum data transmission rate depends on the length of cable:

Cable length	Baud rate
< 50 m	< 400 kHz
< 100 m	< 300 kHz
< 200 m	< 200 kHz
< 400 m	< 100 kHz

Basics of Absolute Encoders ACURO

INTERBUS

GENERAL INFORMATION

INTERBUS is a real-time bus for the sensor-actor-level which is able to transfer data with a small overhead in a range of up to 4 bytes per subscriber for a maximum of 256 subscribers.

It is characterized by a circular transmission with a fixed message frame and a central master (e.g. SPC switching-in assembly).

TRANSFER SEQUENCE

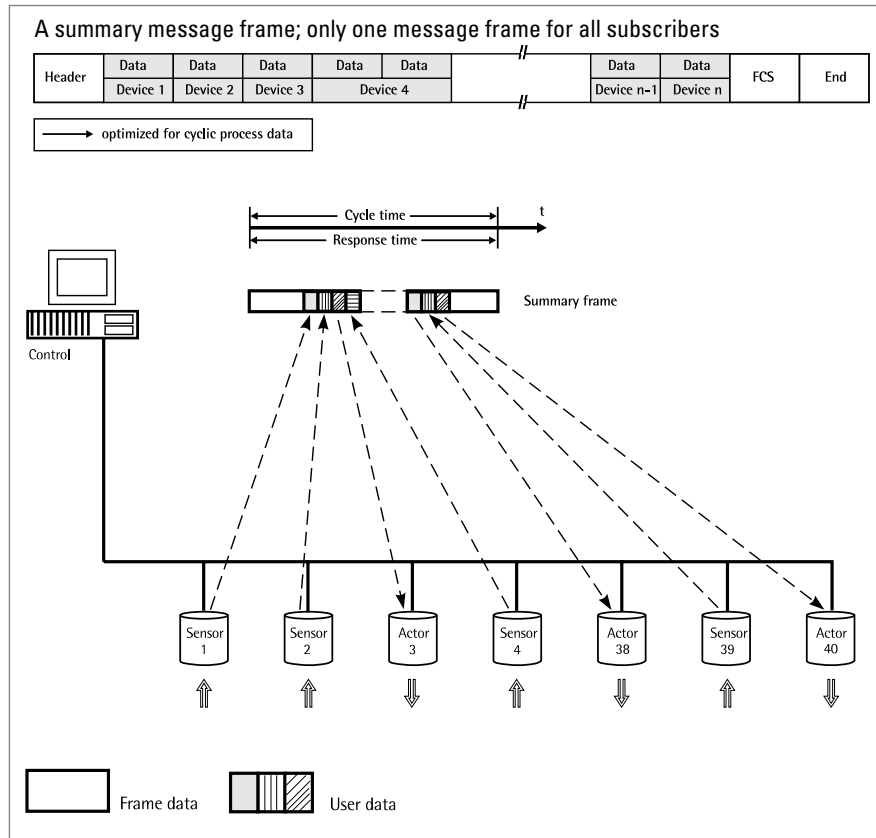

WHAT ARE THE BENEFITS OF INTERBUS COMPARED WITH A CONVENTIONAL SYSTEM WIRING?

- Lower costs for cables and wiring
- Lower noise sensitivity
- Many control signals which were analog before are now available as digital signals and directly transferable by INTERBUS
- Simple layout, installation and starting procedure
- High efficiency (net data rate): the percental share of the message header and of the terminating sequence decreases with a growing number of subscribers
- Data of all subscribers are stored at the same time and transferred sub-sequently
- Reaction time can easily be determined. It only depends on the system's total extension; this is important for controlling tasks
- Constant sampling rate for reference inputs and actual values; both are transferred in one bus cycle
- Considerations of priority are unnecessary since all subscribers have the same priority

INTERBUS

- No system-parameter definition before starting procedure
- Data integrity is secured by 16-bit-CRC (according to CCITT polynomial) done for each transmission
- Sophisticated diagnostic software for the central bus controller: a point of error can specifically be isolated; in each case of malfunction there is a possibility to close the circular system in every single bus clip.

Devices with an INTERBUS interface for process control are now available from more than 200 manufacturers.

Encoder manufacturers are joined together in the ENCOM user group; drive manufacturers in DRIVECOM.

The user groups shall maximize the benefit for the customer by standardization of data transmission.

There is a high availability of devices with INTERBUS interface, and the bus mode has already been successful in industrial use.

ENCOM USER GROUP



The following device classes defined by ENCOM are used for absolute shaft encoders:

Class 2 (K2):

- 32-bit process data
- Binary
- Right-justified
- Readable only
- No control bits or status bits

Class 3 (K3):

- 32-bit process data
- Coded according to manufacturer specifications
- Right-justified
- 7 status bits and control bits

Basics of Absolute Encoders ACURO

INTERBUS

TECHNICAL DATA

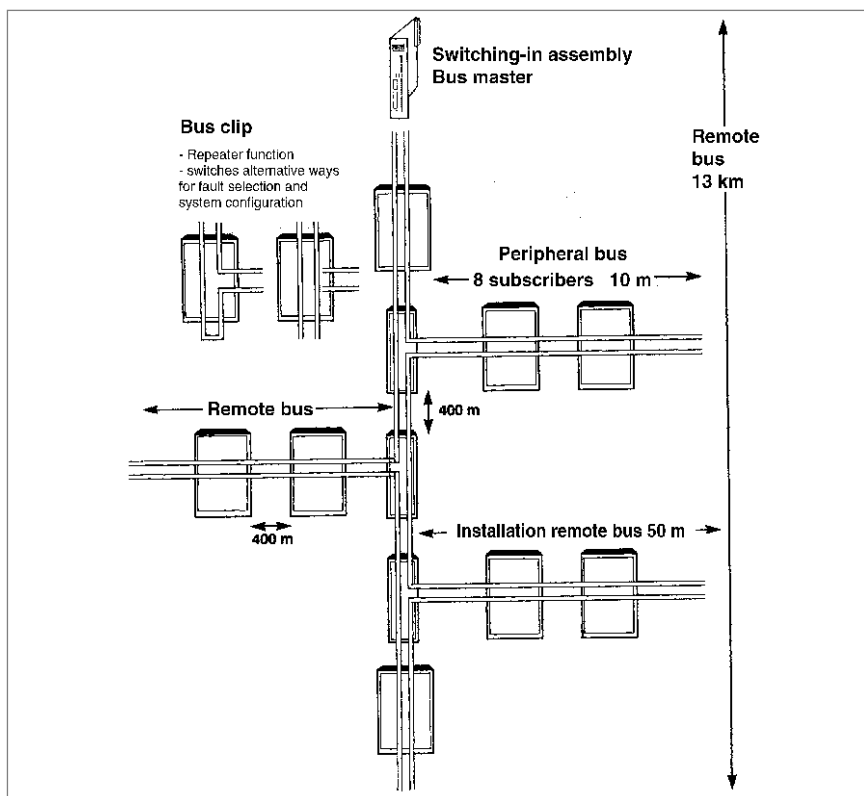

INTERBUS is physically divided into:

Remote bus

- Voltage difference transmission RS 485
- Max. cable length between two bus clips: 400 m
- Max. overall cable length of remote bus: 13 km
- A maximum of 64 bus clips/modules may be directly connected to the remote bus

Peripheral bus

- 5 V voltage interface
- Max. overall cable length of peripheral bus: 10 m
- A maximum of 8 modules may be connected

Installation remote bus

- For modules with enclosure class IP65 (e.g. HENGSTLER absolute shaft encoders)
- Voltage difference transmission RS 485
- Max. overall cable length: 50 m
- Connection via bus clip or passive T-manifold
- Each subscriber has an electrically isolated voltage transformer
- 24 V supply may be led via the bus line or be connected to the T-manifold
- 8 modules may be connected.

The transmission speed is **500 kBit/s**.

INTERBUS

INTERBUS DIAGNOSTIC CONCEPT

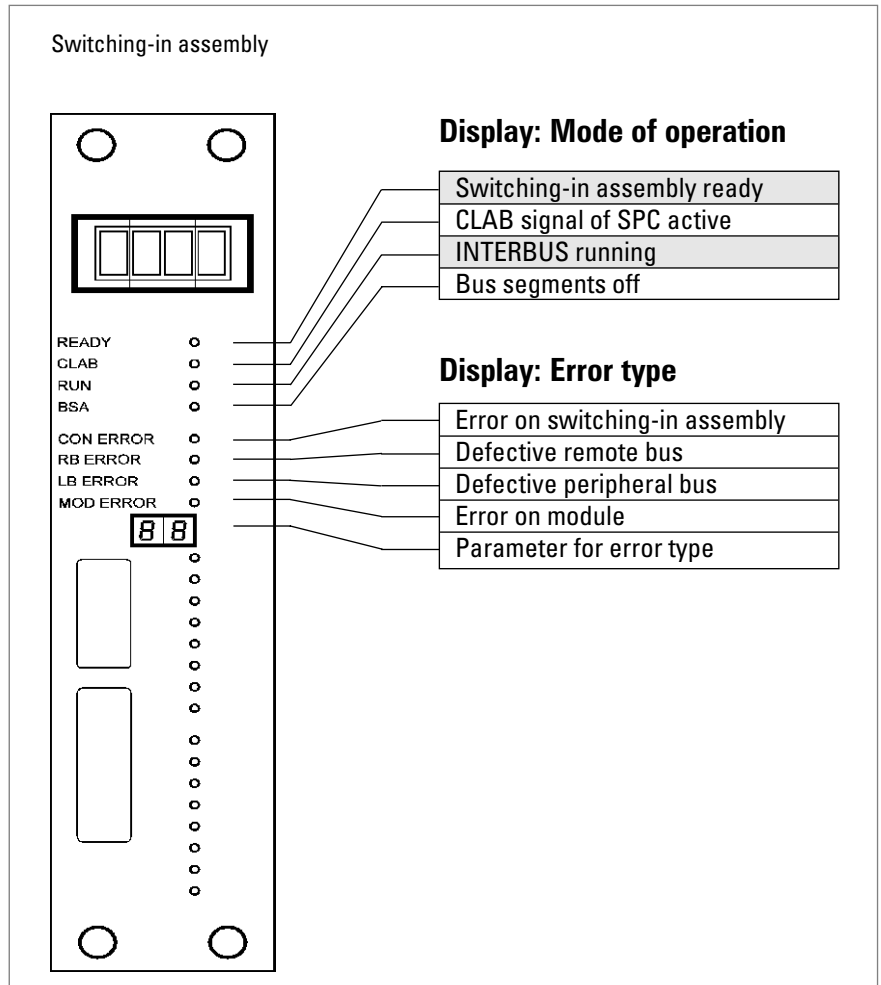

The diagnostic system is able to indicate peripheral and controller errors beside the selection of faults. Due to a row of LEDs comprising 16 bits, available on most switching-in assemblies, decentralized process states can be displayed centrally.

- Status display on control system for inputs and outputs without hand programming unit

- Self-acting fault detection and display with point and type of error without user programming

- Usual diagnosis by hand programming unit can be kept

- Diagnostic representation is always the same regardless of the control system.

i For further information see:
www.interbusclub.com/de

CANopen

GENERAL INFORMATION

The AC 58 is an absolute shaft encoder (encoder, angle encoder). The version described in this technical manual sends its current position to another station via the "CAN-bus" transmission medium (physically: screened and twisted two-wire line).

The serial bus system CAN (Controller Area Network), which had been originally developed by Bosch/ Intel for automotive uses, is gaining ground in industrial automation technology. The system is multimaster-compatible, i.e. several CAN- stations are able to request the bus at the same time. The message with the highest priority (determined by the identifier) will be received immediately.

The data transfer is regulated by the message's priority. Within the CAN system, there are no transport addresses, but message identifiers. The message which is being sent can be received by all stations at the same time (broadcast).

By means of a special filter methods, the station only accepts the relevant messages. The identifier transmitted with the message is the basis for the decision as to whether the message will be accepted or not.

The bus coupler is standardised according to the international standard ISO-DIS 11898 (CAN High Speed) standard and allows data to be transferred at a maximum rate of 1 MBit/ s. The most significant feature of the CAN-protocol is its high level of transmission reliability (Hamming distance = 6).

The CAN-Controller Intel 82527 used in the encoder is **basic** as well as **full-CAN** compatible and supports the **CAN-specification 2.0 part B (standard protocol with 11-bit- identifier** as well as **extended protocol with 29-bit identifier)**. Up to now, only 11-bit identifiers have been used for CANopen.

FIELD OF APPLICATION

In systems, where the position of a drive or of any other part of a machine has to be recorded and signalled to the control system, the AC 58 can assume this function. The AC 58 can resolve, for instance, positioning tasks by sending the check-back signal concerning the present drive position via the CAN bus to the positioning unit.

Basics of Absolute Encoders ACURO

CANopen

CANOPEN COMMUNICATION MODEL AND PROFILE

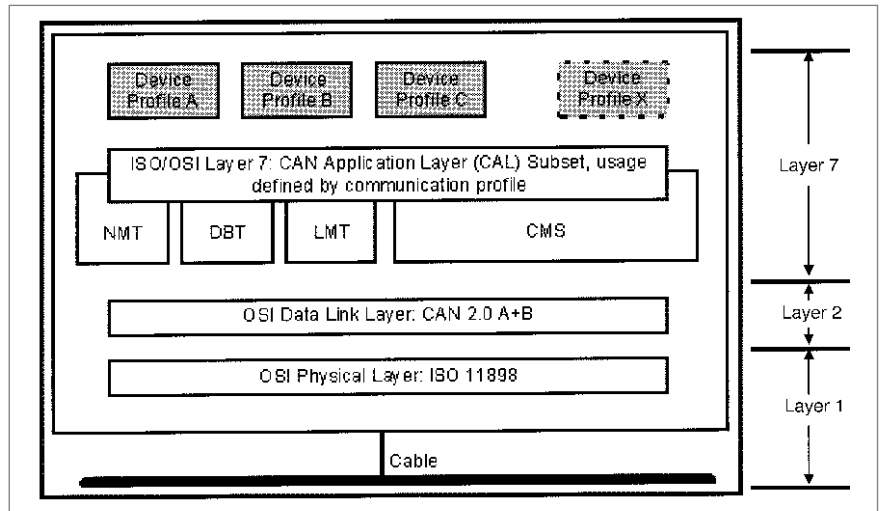

Layer 1 (Physical Layer): ISO-DIS 11898 (CAN High Speed)

Layer 2 (Data Link Layer): ISO-DIS 11898 (CAN High Speed)

Layer 7 (Application Layer): CiA DS 301 (CANopen CAL-based Communication Profile)
+ Device profile CiA DS 4xx (CANopen Device Profile for xx)

For the following devices, profiles already exist:

- CiA Draft Standard Proposal 401 for Input/Output Modules
- CiA Draft Standard Proposal 402 for Drives and Motion Control
- CiA Work Item 403 for Human-Machine Interfaces
- CiA Work Draft 404 for Closed-Loop Controllers and Transformers
- CiA Work Item 405 for IEC-1131 Interfaces
- **CiA Draft Standard Proposal 406 for Encoders**
- CiA Work Item 407 for Public Transport
- CiA Work Item 408 for Fork-Lifts

CANopen

THE CANOPEN PROFILE

About two and a half years after the CiA, the association of the user and manufacturer of CAN products, had adopted the CAN Application Layer (CAL), CANopen and the respective device profiles paved the way for the development of open systems.

CANopen has been developed under the technical direction of the Steinbeis Transfer Centre for Automation (STA Reutlingen; Germany) on the basis of the layer 7 CAL specification.

Compared with CAL, CANopen only provides the functions needed for this special purpose. CANopen is thus a part of CAL which has been optimised for application purposes and allows for a simpler system structure as well as for simpler devices.

CANopen has been optimised for a quick transfer of data in real-time systems and has been standardised for different device profiles.

The CAN in Automation (CiA) association of users and manufacturers is responsible for the establishing and the standardisation of the respective profiles.

The RA58 with CANopen meets the requirements laid down in the communication profile (CiA DS 301) and in the device profile for encoders.

CANopen allows for:

- auto configuration of the network,
- comfortable access to all device parameters.
- synchronisation of the devices,
- cyclical and event-controlled process data processing,
- simultaneous data input and output.

CANopen uses four communication objects (COB) with different features:

- Process Data Objects (PDO) for real-time data
- Service Data Objects (SDO) for the transfer of parameters and programs
- Network Management (NMT, Life-Guarding)
- predefined objects (for synchronisation, time stamp, emergency message)

All device parameters are stored in an object directory. The object directory contains the description, data type and structure of the parameters as well as their addresses (index).

The directory consists of three parts: communication profile parameters, device profile parameters and manufacturer specific parameters.

THE ENCODER DEVICE PROFILE (CIA DSP 406)

This profile describes a binding, but manufacturer-independent definition of the interface for encoders. The profile not only defines which CANopen functions are to be used, but also how they are to be used. This standard permits an open and manufacturer-independent bus system.

The device profile consists of two object categories

- the standard category C1 describes all the basic functions the shaft encoder must contain

- the extended category C2 contains a variety of additional functions which either have to be supported by category C2 shaft encoders (mandatory) or which are optional. Category C2 devices thus contain all C1 and C2 mandatory functions as well as, depending on the manufacturer, further optional functions.

Furthermore, an addressable area is defined in the profile, to which, depending on the manufacturer, different functions can be assigned.

CANopen

DATA TRANSFER

In CANopen, the data is transferred by means of two different communication types (COB = Communication Object) with different features:

- **Process Data Objects (PDO)**
- **Service Data Objects (SDO)**

The priority of the message objects is determined by the COB identifier.

The **process data objects (PDO)** serve the highly dynamic exchange of real-time data (e.g. position of the shaft encoder) with a maximum length of 8 Byte. This data is transferred with high priority (low COB identifier). PDOs are broadcast messages and put their information simultaneously at the disposal of all desired receivers.

The **service data objects (SDO)** form the communication channel for the transfer of device parameters (e.g. programming of the shaft encoders' resolution). Since these parameters are transferred acyclically (e.g. only once when running up the network), the SDO objects have a low priority (high COB identifier).

COB IDENTIFIER

For an easier administration of the identifiers, CANopen uses the "Predefined master/Slave Connection Set"). In this case, all identifiers with standard values are defined in the object directory. However, these identifiers can be modified according to the customers' needs via SDO access.

The 11-bit identifier consists of a 4 Bit function code and a 7 Bit node number.

Bit-No.	10	9	8	7	6	5	4	3	2	1	0
Type	Function code				Node number						
Assignment ¹	x	x	x	x	0	0	x	x	x	x	x

¹ x = binary value can be selected freely 0 or 1); 0 = 0 value is fixed

The higher the value of the COB identifier, the lower the identifier's priority!

NODE NUMBER

The 7-bit node number is set by means of the hardware via the 5 DIP switches on the encoder's back.



For further information see CAN user organisation:

www.can-cia.de

Basics of Absolute Encoders ACURO

DeviceNet

BACKGROUND AND TECHNOLOGY

Background

- The basic technology was developed by Allen-Bradley
- Introduced in March 1994
- The ODVA (Open DeviceNet Vendor Association) was founded in April 1995

Technology

- CAN-Layer 2 (Data Link Layer) - ISO 11898 and 11519-1
- DeviceNet covers layer 7 (Application Layer) and layer 1 (Physical Layer), developed for industrial automation

Main benefits

- Reduced cabling and installation effort
- Reduced run-in time
- Reduced down-time
- Fast error elimination
- Devices can be removed, replaced and inserted without having to shut the network down
- Devices from various manufacturers can be exchanged
- Devices are configured over the network

LINEAR BUS TOPOLOGY

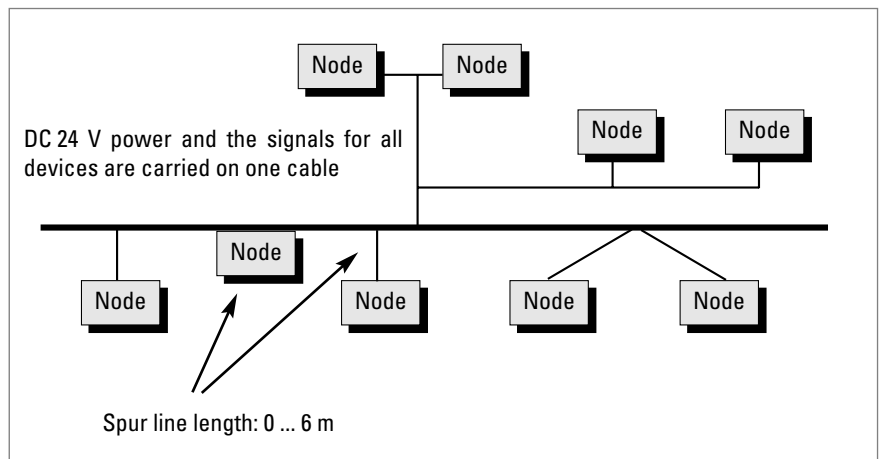

NETWORK SPECIFICATION

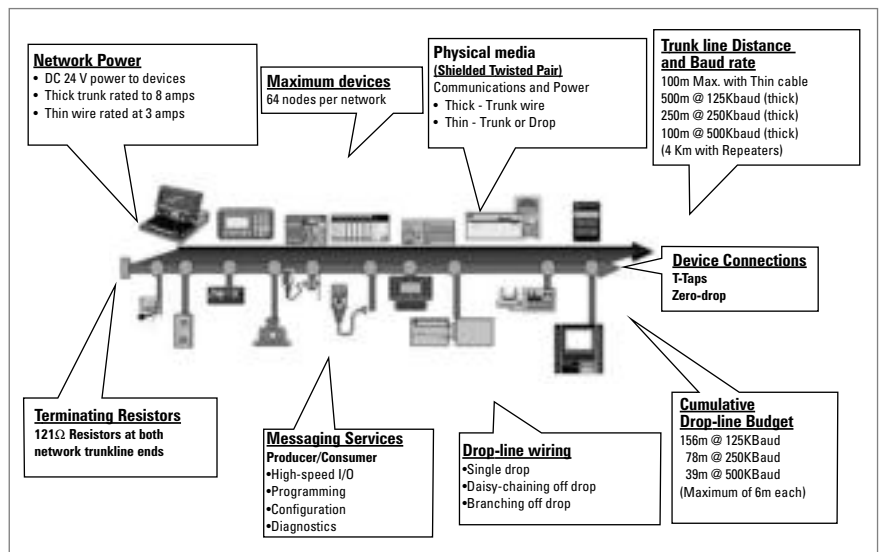

For more information about deviceNet please contact:

<http://www.odva.org>

e-mail: odva@powerinternet.com

Profibus-DP

GENERAL INFORMATION

The basic functions of the PROFIBUS DP are here only described in extracts. For additional information, please refer to the standards on PROFIBUS DP, i.e. DIN 19245-3 and EN 50170 respectively.



INTRODUCTION

The AC 58 is an absolute shaft encoder (encoder, angle encoder). The version described in this manual sends its current position to another station via the transmission medium "PROFIBUS DP" (physically: screened and twisted pair line). The AC 58 supports all class 1 and 2 functions listed in the encoder profile.

PROFIBUS-DP is manufacturer independent, open field bus standard for a variety of applications in the field of production, process and building services automation. The requirements of openness and independence from the manufacturer are stipulated in the European standard EN 50 170.

PROFIBUS-DP permits the communication of devices produced by different manufacturers without any particular adaptations of the interfaces.

PROFIBUS DP is a special standard version for a quick data exchange within the field level which has been optimised in terms of speed and low connection costs. Central control systems like, for example SPC/ PC communicate via a quick, serial connection with local field devices like drives, valves, or encoders. The data exchange between these devices is predominantly cyclical. The communication functions required for this exchange are determined by the basic functions of the PROFIBUS DP according to the EN 50 170 European standard.

FIELD OF APPLICATION

In systems, where the position of a drive or of any other part of a machine has to be recorded and signalled to the control system, the AC 58 can assume this function.

The AC 58 can resolve, for instance, positioning tasks by sending the checkback signal concerning the present drive position via the PROFIBUS DP to the positioning unit.

BASIC FUNCTIONS OF THE PROFIBUS-DP

The central control system (master) cyclically reads out the input information from the slaves and writes the output information to the slaves. For this purpose, the bus cycle time has to be shorter than the program cycle time of the central SPC, which amounts to approx. 10 ms for various applications.

Apart from the cyclical user data transfer, the PROFIBUS DP version also disposes of powerful functions for diagnosis and initial operation procedures. The data traffic is controlled by watchdog functions on both the slave and the master side. The following table summarises the basic functions of the PROFIBUS DP.

Basics of Absolute Encoders ACURO

Profibus-DP

Transmission technology:	<ul style="list-style-type: none">• RS-485 twisted pair line• Baud rates ranging from 9.6 kBit/s up to 12 MBit/s
Bus access:	<ul style="list-style-type: none">• Token passing procedure between the masters and master-slave procedures for slaves• Monomaster or multimaster systems possible• master and slave devices, max. of 126 stations at a single bus
Communication:	<ul style="list-style-type: none">• Point-to-point (user data communication) or multicast (control commands)• cyclical master-slave user data communication and acyclical master-master data transfer
Operating state:	<ul style="list-style-type: none">• Operate: cyclical transfer of input and output data• Clear: The input data are read, the output data remain in the safe status• Stop: only master-master data transfer is possible
Synchronisation:	<ul style="list-style-type: none">• Control commands enable a synchronisation of the input and output data• Sync mode: Output data are being synchronised
Functionality:	<ul style="list-style-type: none">• Cyclical user data transfer between DP master and DP slave(s)• Single DP slaves are dynamically activated or deactivated• Control of the DP slave's configuration. Powerful diagnostic functions, 3 stepped diagnostic message levels.• Synchronisation of in- and/ or output• Address assignment for the DP slaves via the bus• Configuration of the DP masters (DPM1) via the bus• Maximum of 246 byte input and output data per DP slave possible
Protection functions:	<ul style="list-style-type: none">• All messages are transferred with a hamming distance of HD=4• Response control at the DP slaves• Access protection of the DP slaves' input/ output• Monitoring of the user data communication with adjustable control timer at the master
Device types:	<ul style="list-style-type: none">• DP master class 2 (DPM2), e.g. programming/ project planning devices• DP master class 1 (DPM1), e.g. central automation devices like SPC, PC• DP slave e. g. devices with binary or analogue input/ output, drives, valves

ESSENTIAL FEATURES/SPEED

The PROFIBUS DP only requires approx. 1 ms at a speed of 12 MBit/s in order to transfer 512 Bit input and 512 Bit output data by means of 32 stations.

The following diagram shows the usual PROFIBUS DP transfer time interval in relation to the number of stations as well as the transmission speed. The high speed can be above all explained by the fact that the input and output data within a message cycle are transferred by using the layer 2 SRD service (Send and Receive Data Service).

Diagnostic function:

The comprehensive diagnostic functions of PROFIBUS DP allow a quick localisation of the errors. The diagnostic messages are transferred by means of the bus and are assembled at the master. They are subdivided in three levels:

Profibus-DP

BASIC FEATURES/SPEED

Station-related diagnosis

Messages on the general readiness for service of a station, like for example, overtemperature or undervoltage.

Channel related diagnosis

The error cause in relation to a single input/output bit (channel) is indicated here, like for example, a short-circuit at output line 7.

Module-related diagnosis

These messages indicate that a diagnosis within a certain I/O part (e.g. 8 Bit output module) of a station is in hand.

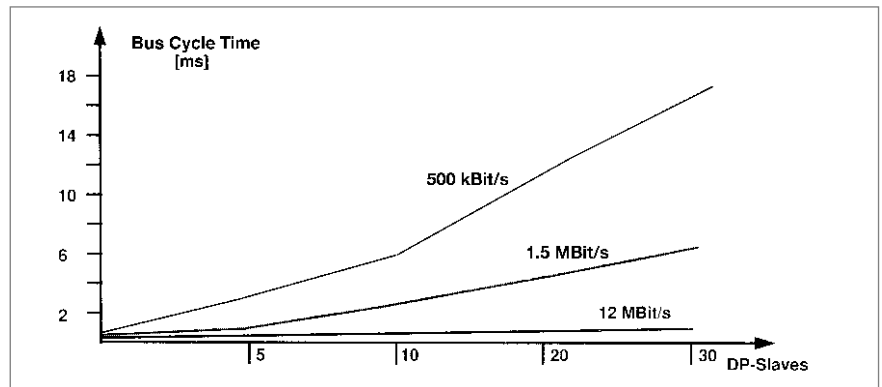

Bus cycle time of a PROFIBUS DP monomaster system

Boundary conditions: Each slave has 2 byte input and 2 byte output data; the minimum slave interval time amounts to 200 microseconds; TSDI = 37 Bit times, TSDR = 11 Bit times

CONFIGURATION OF THE SYSTEM AND DEVICE TYPES

By means of PROFIBUS DP, mono- and multimaster systems can be realised. For this reason, a high level of flexibility in terms of the system configuration can be achieved. A maximum of 126 devices (master or slaves) may be connected to a bus. The definitions for the system configuration contain the number of stations, the assignment of the station address to the I/O addresses, the data consistency of the I/O data, the format of the diagnostic messages and the bus parameters used. Each PROFIBUS DP system consists of different device types. There are three device types to be distinguished:

DP master class 1 (DPM1)

These devices are central control systems exchanging information with the local stations (DP slaves) during a fixed message cycle. Typical devices of this kind are stored-program controllers (SPC), PC or VME systems.

DP master class 2 (DPM2)

Programming, configuration devices, and operator panels belong to this category. They are used for the initial operation procedures in order to establish the configuration of the DP system, or to operate the plants in the course of operation.

DP slave

A DP slave is a peripheral I/O rack (I/O, drives, HMI, valves) that reads the input information and sends output information to the peripheral equipment. Devices which provide only input or only output information might also be used.

The amount of input and output information is device specific and must not exceed 246 byte for the input and 246 byte for the output data.

Basics of Absolute Encoders ACURO

Profibus-DP

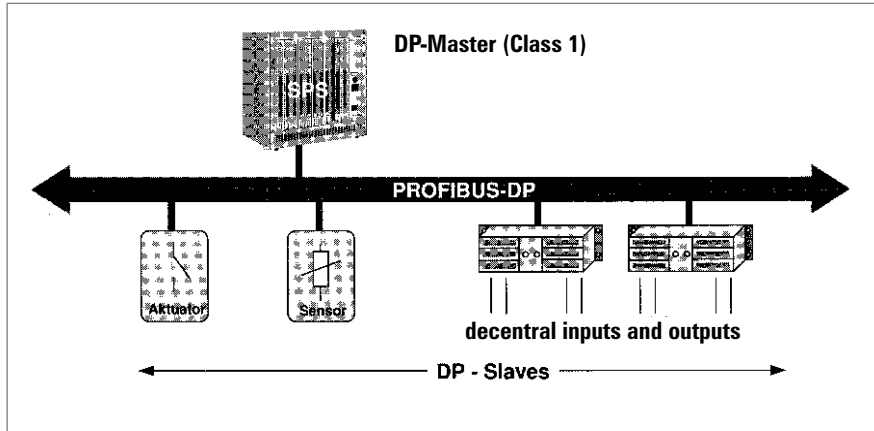

PROFIBUS DP monomaster system

In the case of monomaster bus systems, there is only one master active at bus during the on-line phase of the bus system. The above diagram shows the system configuration of a monomaster system. The SPC based control system is the central control element. By means of the transmission medium, the DP slaves are locally linked to the SPC control system. By using this system configuration, the shortest bus cycle time can be obtained.

In the multimaster mode, several masters are linked to a single bus. They either form independent subsystems consisting of one DPM1 and its corresponding DP slaves each, or additional configuration and diagnostic devices (see diagram below). The I/O maps of the DP slaves can be read by all DP masters, but only one DP master, the one which has been assigned DPM1 during project planning, is able to write the output information. Multimaster systems attain a medium bus cycle time.

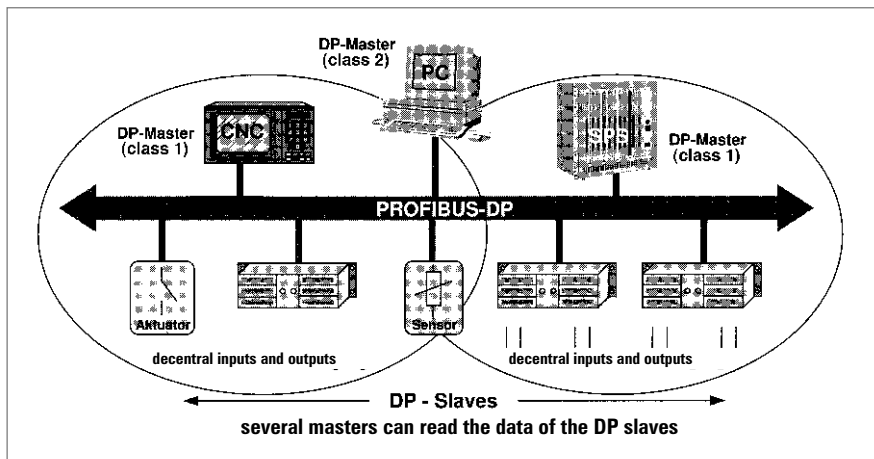

PROFIBUS-DP Multi-Master System

Profibus-DP

SYSTEM PERFORMANCE

In order to obtain a high level of exchangeability between the devices, the system performance of PROFIBUS DP has also been standardised. It is mainly determined by the operational status of the DPM1.

The DPM1 can either be controlled locally or via the bus by the project planning device. The following three main states can be distinguished:

Stop

There is no data traffic between DPM1 and the DP slaves.

Clear

The DPM1 reads the input information of the DP slaves and maintains the safe status of the DP slaves' output.

Operate

The DPM1 has entered the data transfer phase. In case of a cyclical data traffic, the input is read by the DP slaves while the output is transferred to the DP slaves.

After an error has occurred during the data transfer phase of the DPM1, like for example, the failure of a DP slave, the response of the system is determined by the operating parameter "Auto Clear".

If this parameter has been set to true, the DPM1 will set the output of all the respective DP slaves to the safe status, as soon as a DP slave is no longer available for user data communication. Afterwards, the DPM1 changes to the clear status.

If this parameter is = false, the DPM1 remains, even if an error occurs, in the operate status, and the user can determine the response of the system at his own discretion.

CYCLICAL DATA TRANSFER BETWEEN DPM1 AND THE DP SLAVES

The data traffic between the DPM1 and the respective DP slaves is automatically handled by the DPM1 in a fixed, recurring order. When configuring the bus system, the user assigns a DP slave to the DPM1. In addition, the slaves to be included in- or excluded from the user data communication are defined.

The data traffic between the DPM1 and the DP slaves is subdivided in parametrisation, configuration, and data transfer phases. Before including a DP slave in the data transfer phase, the DPM1 checks during the parametrisation and configuration phase, whether the planned set configuration corresponds to the actual configuration of the device.

For this check, the device type, the information on the format and the length as well as the number of input and output lines have to be correct. The user thus obtains a reliable protection against parametrisation errors. In addition to the user communication, which is automatically executed by the DPM1, the user may request the new parametrisation data to be sent to the DP slaves.

Basics of Absolute Encoders ACURO

Profibus-DP

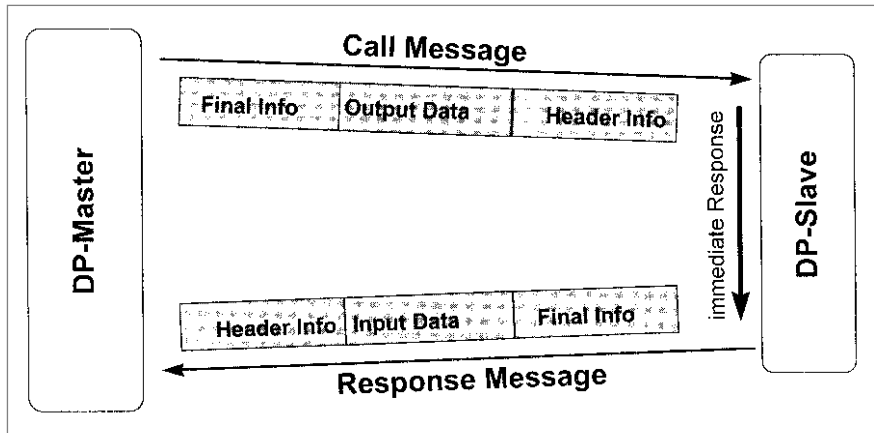

User data communication for PROFIBUS-DP

DATA TRAFFIC BETWEEN DPM1 AND PROJECT PLANNING DEVICES

In addition to the functions between DP master and DP slaves, master-master communication functions are available, see table. They support the project planning and diagnostic devices in projecting the system via the bus.

Besides the upload and download functions, the master-master functions offer the opportunity to switch the user data transfer between the DPM1 and the single DP slaves dynamically on or off as well as to modify the operating status of the DPM1.

Function	Meaning	DPM1	DPM2
Get_master_Diag	reads the diagnostic data of the DPM1 or the collective diagnosis of the DP slaves.	M	0
Download / Upload Group (Start_Seq, Down-/Upload, End_Seq)	reads or writes the entire configuration data of a DPM1 and of the respective DP slaves.	0	0
Act_Para_Brct	activates the bus parameters for all operating DPM1 devices.	0	0
Act_Param	activates parameters or modifies the operating status of the operating DPM1 device.	0	0

M: mandatory, 0: optional

Functional overview for the master-master functions for PROFIBUS DP

Profibus-DP

SYNC MODE

In addition to the station-related user data communication being automatically handled by the DPM1, the masters may send control commands to a single slave, a group of slaves or all slaves at the same time. These control commands are transferred as multicast. It is only by means of this multicast that the sync and freeze operating modes for the event-controlled synchronisation of the DP slaves have been enabled.

The sync mode is started by the slaves, as soon as they receive a sync command from the respective master. The output lines of the addressed slaves will then be frozen in their current state. The output data will be stored at the slaves during the following user data transfers; the state of the output lines, however, will remain unchanged. Unless the next sync command has been received, the stored output data will not be connected to the output lines. By selecting unsync, the sync mode is terminated.

PROTECTIVE MECHANISMS

For reasons of safety, it is necessary to equip PROFIBUS DP with powerful protective functions against false parametrisation or failure of the transmission equipment. For this purpose, control mechanisms at the DP master and the DP slave have been realised, taking the form of time-out circuits. The monitoring interval is determined during project planning.

At the DP master

The DPM1 controls the data traffic of the slaves by means of the Data_Control_Timer. For each slave, a special timer is used. The time-out circuit will respond, if no proper user data transfer occurs during a control interval. In this case, the user will be informed. If the automatic response to an error (Auto_Clear = True) has been released, the DPM1 will quit the operate status, switch the output lines of the respective slaves to the safe status and change to the clear status.

At the DP slave

In order to recognise errors by the master or transmission errors, the slave executes the response control. If there is no data traffic during the response control interval, the slave will automatically switch the output lines to the safe status.

When operating in multimaster systems, a supplementary access protection for the I/O lines of the slaves will be necessary. This is to make sure that direct access can only be gained by an authorised master. For all the other masters, the slaves will provide an I/O map which can be also be read without access authorisation.

COMMUNICATION INTERFACE

The communication interface corresponds to the PROFIBUS DP class 2 encoder profile.

Within this interface the class 1 functions are included.



For further information see:
www.profibus.de

Glossary of Technical Terms

Absolute shaft encoder	Shaft encoder that transmits unique coded data for each increment.
Accuracy	The difference between the actual and measured position.
Alarm signal	Serves to monitor the shaft encoder for malfunctions, such as glass breakage, fouling, short circuit, short circuit of signal line, and supply voltage too low.
Amplitude regulation	Current or voltage amplitude is constant through regulation
Analogue signal	A signal whose level alters continuously.
ASIC	Application specific integrated circuit
Axial loading	Maximum load on the shaft encoder's shaft in the axial direction
Bandwidth	Frequency range for output signals
Baud rate	Rate of data transfer (bits per second).
BCD	Binary-coded decimal; binary representation of a decimal number.
Binary	Two logical states (yes/no); the basis of binary data-processing systems.
Binary code	Code using binary numbering; often used for absolute measuring systems.
Bit	Abbreviation for "binary digit"; the smallest unit of information of a binary system, whose value can be 1 or 0 (yes-or-no decision).
Bus cycle	Time needed for polling every bus slave by the bus master.
Byte	Sequence of 8 Bits.
CAL	Can application layer
CANopen	Layer 7 protocol based on CAN
CCW	Counter clockwise
Change of state	For CAN: Bus node (encoder) sends it's data automatically when a position change occurs.
Channel	Signal track on which 1 or 0 is outputted.
CiA	CAN in automation (CAN users and manufacturers group)
CiA DS	CAN in automation draft standard, communication profile
CiA DSP	CAN in automation draft standard proposal, communication profile
CIM	Computer Integrated Manufacturing; i. e. the linking of different computer-aided processes in production and related fields for general use of the data.
CMD	Software tool for configuration and diagnosis of Interbus networks
COB	Communication object
Code	Format in which data are transmitted.
Code switching frequency	Number of position steps per second. For absolute shaft encoders with parallel interface: The maximum output frequency of the LSB output driver (f_{max}) also limits the maximum permissible code switching frequency: Code switching frequency max. = $2 \cdot f_{max}$ for Binary code Code switching frequency max. = $4 \cdot f_{max}$ for Gray code

Glossary of Technical Terms

Coefficient of thermal expansion	Material expansion under influence of temperature change [$\mu\text{m}/^\circ\text{K m}$], relevant for linear scales.
Complementary	Output circuit for which also the inverted signals are outputted (e.g. Channel A and Channel A). Electrically, the 1/0 levels are transmitted as voltage differences between two lines. In this way the information signal (the difference) remains pure as in general interferences are interspersed equally on both lines.
CRC	Cyclic redundancy check. Bit error protection method for data communication.
CW	Clockwise
Data bus	System of lines over which data are transferred electronically in parallel or serially.
Data consistency	Intrinsic coherence of data in respect of timing and logical aspects.
Data integrity	Correspondence of data with the reality that they describe.
Datavalid	Output for checking the validity of data.
DC	Direct current (not alternating)
Demodulator	Device that filters the original information out of an altered signal again.
DeviceNet - conformity and interoperability	Confirmation of agreement of a bus node with the DeviceNet specifications and correct interoperability with other DeviceNet nodes.
Differential line driver	Output circuit in which the difference between the two signals A and A is evaluated, thus providing high signal transmission reliability.
DIN	Deutsche Industrie Norm (German Industrial Standard)
Direction	Control input for determining the data sequence (whether ascending for clockwise or counterclockwise rotation).
Dual Code	Natural binary code
EDS - File	Electronic data sheet. This is a file with the device specific parameter description and is provided by the manufacturer of a DeviceNet or CANopen device.
EEPROM	"Electrically Erasable Programmable Read-Only Memory" chip (see EPROM).
EIA	Electronic Industries Association; U.S. umbrella organization of manufacturers of electronic equipment and facilities. It is responsible for maintenance and development of the industrial standards for interfaces between data-processing devices and data communications equipment.
EMC	Electromagnetic compatibility
ENCOM	User group of manufacturers of INTERBUS-S absolute shaft encoders
Encoder monitoring	See "Alarm signal"
Enable	Control input via which the data outputs can be activated.
Encoder power	Supply voltage to be provided for the shaft encoder.
EPROM	"Erasable Programmable Read-Only Memory" chip, which can be erased with ultraviolet light, after which new data can be written into it.
Gray code	A special binary code that changes only one data bit per measuring step at a time. It is used with absolute encoders.

Glossary of Technical Terms

Hamming distance	Measure for data security in a data transmission. The higher the number the better the ability to detect data errors.																												
Harmonic Distortion	Measure for the signal quality of sinewave encoder [%]. It describes the content of harmonics in analogue signals. The lower the number the better the signal.																												
Hysteresis error	Measurement deviation for a position approached from opposite directions.																												
Identifier	Address of a message in a CAN network.																												
IEC	International Electrotechnical Commission; organization promoting international standardization of electrical components.																												
Immunity to interference	<p>Test procedure according to IEC 801, Part 4</p> <p>– A test of susceptibility to fast electrical transients (bursts) causing interference on lines.</p> <p>The test values are divided into 5 levels:</p> <table border="1" style="width: 100%; border-collapse: collapse;"> <thead> <tr> <th style="text-align: left;">Level</th> <th style="text-align: left;">Mains line</th> <th style="text-align: left;">Data and control lines</th> </tr> </thead> <tbody> <tr> <td>1</td> <td>0.5 kV</td> <td>0.25 kV</td> </tr> <tr> <td>2</td> <td>1.0 kV</td> <td>0.5 kV</td> </tr> <tr> <td>3</td> <td>2.0 kV</td> <td>1.0 kV</td> </tr> <tr> <td>4</td> <td>4.0 kV</td> <td>2.0 kV</td> </tr> <tr> <td>X</td> <td>special</td> <td>special</td> </tr> </tbody> </table> <p>– Test procedure according to IEC 801, Part 2</p> <p>Discharge of static electricity on the surface and in the surroundings of the specimen. The test values are divided into 4 classes:</p> <table border="1" style="width: 100%; border-collapse: collapse;"> <thead> <tr> <th style="text-align: left;">Class</th> <th style="text-align: left;">test voltage</th> </tr> </thead> <tbody> <tr> <td>1</td> <td>2 kV</td> </tr> <tr> <td>2</td> <td>4 kV</td> </tr> <tr> <td>3</td> <td>8 kV</td> </tr> <tr> <td>4</td> <td>15 kV</td> </tr> </tbody> </table> <p>– Radio interference voltage test to VDE 0871.</p>	Level	Mains line	Data and control lines	1	0.5 kV	0.25 kV	2	1.0 kV	0.5 kV	3	2.0 kV	1.0 kV	4	4.0 kV	2.0 kV	X	special	special	Class	test voltage	1	2 kV	2	4 kV	3	8 kV	4	15 kV
Level	Mains line	Data and control lines																											
1	0.5 kV	0.25 kV																											
2	1.0 kV	0.5 kV																											
3	2.0 kV	1.0 kV																											
4	4.0 kV	2.0 kV																											
X	special	special																											
Class	test voltage																												
1	2 kV																												
2	4 kV																												
3	8 kV																												
4	15 kV																												
Incremental measuring system	Measuring method in which the variable is formed by counting increments (measuring steps).																												
Incremental shaft encoder	Shaft encoder which transmits an electrical signal (yes/no) for each increment, determined by the marked disc.																												
Integer	Integral values; range of values at n bit: 0 ... (2 ⁿ -1)																												
Integrated coupling	Flexible coupling built into shaft encoders																												
INTERBUS	Real time bus for the sensor-actor-level																												
Interbus-Loop	Two wire version of Interbus, transmitting data over the power supply lines and using Phoenix Contact "Quickon" cable plugs.																												
Interface	Transfer point with certain terminals, signals, or signal sequences. The interface serves for communication of the shaft encoder with other systems.																												
Interpolation	Scanning of a sinewave signal to increase resolution by generating intermediate position values.																												
IP	See "Protection class"																												
Jitter	Change in the phase angle between Channel A and B within one revolution (360°).																												
Latch	Control input for storing ("freezing") the data before they are read out.																												

Glossary of Technical Terms

Linearity	Deviation of the reading from the actual value within one revolution (360°).																												
Line driver	Output circuit that makes a larger current possible.																												
LSB	Least Significant Bit																												
Measuring wheel	A wheel that, mounted on a shaft encoder, converts a linear motion into a rotary motion.																												
MSB	Most Significant Bit																												
MTBF	“Mean Time Between Failures”, a measure of average service life.																												
Multi-turn shaft encoder	Shaft encoder which transmits the number of shaft revolutions as well as the angular position of the shaft.																												
NC machinery	Numerically Controlled machinery; their movements are programmed.																												
NPN input/output	Transistor input/output circuit implemented with an npn transistor, and thus negative switching.																												
Offset	For programmable absolute shaft encoders: the offset value is added to the value of physical position. As a result you get a relative shift of the output value (output value = position value + offset value).																												
Parallel interface	Transfer point at which the data are transferred in parallel over several lines.																												
Parity	Checkbit for error detection in data transfer																												
PDO	Process data object (in CAN networks)																												
P.L.C.	Programmable Logic Controller: control system whose program is stored in a program memory and can be changed.																												
Phase discriminator	Sense-of-direction detector that functions by evaluating the phase angle between Signal A and Signal B.																												
Phase tolerance	Deviation of the pulse-edge from Channel A to B, relative to the phase angle 90°.																												
PNP input/output	Transistor input/output circuit implemented with a pnp transistor, and thus positive switching.																												
Preset	For programmable absolute shaft encoders: The programmed numerical value is accepted as output value (output value = preset value).																												
Protection class	<p>The enclosure class is designated according to DIN 40050, by IP and a two-figure code number.</p> <table> <tr> <td>1st digit</td> <td>Degree of protection against ingress of solid bodies:</td> </tr> <tr> <td>0</td> <td>no special protection</td> </tr> <tr> <td>1</td> <td>solid bodies with dia. > 50 mm, no protection against intentional penetration</td> </tr> <tr> <td>2</td> <td>solid bodies with dia. > 12 mm, warding off fingers etc.</td> </tr> <tr> <td>3</td> <td>solid bodies with dia. > 2.5 mm, warding off tools, wires, etc. (thickness > 2.5 mm)</td> </tr> <tr> <td>4</td> <td>solid bodies with dia. > 1 mm, warding off tools, wires, etc. (thickness > 1 mm)</td> </tr> <tr> <td>5</td> <td>dust in harmful quantities, complete shock-hazard protection</td> </tr> <tr> <td>6</td> <td>dust (dust-tight), complete shock-hazard protection</td> </tr> <tr> <td>2nd digit</td> <td>Degree of protection against water</td> </tr> <tr> <td>0</td> <td>no special protection</td> </tr> <tr> <td>1</td> <td>water dripping vertically</td> </tr> <tr> <td>2</td> <td>water dripping at angles up to 15° from vertical</td> </tr> <tr> <td>3</td> <td>water dripping at angles up to 60° from vertical (spraying water)</td> </tr> <tr> <td>4</td> <td>water from all directions (splashing water)</td> </tr> </table>	1st digit	Degree of protection against ingress of solid bodies:	0	no special protection	1	solid bodies with dia. > 50 mm, no protection against intentional penetration	2	solid bodies with dia. > 12 mm, warding off fingers etc.	3	solid bodies with dia. > 2.5 mm, warding off tools, wires, etc. (thickness > 2.5 mm)	4	solid bodies with dia. > 1 mm, warding off tools, wires, etc. (thickness > 1 mm)	5	dust in harmful quantities, complete shock-hazard protection	6	dust (dust-tight), complete shock-hazard protection	2nd digit	Degree of protection against water	0	no special protection	1	water dripping vertically	2	water dripping at angles up to 15° from vertical	3	water dripping at angles up to 60° from vertical (spraying water)	4	water from all directions (splashing water)
1st digit	Degree of protection against ingress of solid bodies:																												
0	no special protection																												
1	solid bodies with dia. > 50 mm, no protection against intentional penetration																												
2	solid bodies with dia. > 12 mm, warding off fingers etc.																												
3	solid bodies with dia. > 2.5 mm, warding off tools, wires, etc. (thickness > 2.5 mm)																												
4	solid bodies with dia. > 1 mm, warding off tools, wires, etc. (thickness > 1 mm)																												
5	dust in harmful quantities, complete shock-hazard protection																												
6	dust (dust-tight), complete shock-hazard protection																												
2nd digit	Degree of protection against water																												
0	no special protection																												
1	water dripping vertically																												
2	water dripping at angles up to 15° from vertical																												
3	water dripping at angles up to 60° from vertical (spraying water)																												
4	water from all directions (splashing water)																												

Glossary of Technical Terms

Protection class (continued)	<p>2nd digit Degree of protection against water</p> <p>5 water from a nozzle from all directions (hose-water)</p> <p>6 heavy seas or strong jet of water (flooding)</p> <p>7 water, if the device is immersed in water under specified conditions of pressure and time (immersion)</p> <p>8 water, if the device is submerged constantly. The manufacturer must describe the conditions (submersion)</p> <p>(For numbers 1 to 8, water must not penetrate in harmful quantities.)</p> <p>Example: IP65 A device thus designated is dust-tight, and protected against hose-water.</p>
PVC	Polyvinylchloride; plastic coating of device cable
PTB approval	Approval for use by the Physikalisch-Technische Bundesanstalt, the German government materials testing institute.
Pulse (repetition) frequency, max. speed	The maximum signal frequency achievable by the shaft encoder, the product of rotary and number of markings.
Radial load, max.	Maximum loading of shaft encoder shaft in radial direction.
Quickon	Connector with self contacting cable cutting contacts from Phoenix Contact used with Interbus Loop
RAM	"Random Access Memory" chip; this memory can be read from, written to, and erased freely. When the power goes off, it loses its information.
Reference mark	Irregular gradation pattern that generates a single signal peak, to provide an absolute reference for an incremental shaft encoder.
Reference pulse	Square-wave signal generated by a reference mark, usually only one increment wide, to provide an absolute reference for an incremental shaft encoder.
Repeatability	Degree of deviation for a point approached repeatedly under identical operating conditions.
Resolution	Number of increments per revolution (rotary) or distance between two increments (linear)
Resolver	Inductive angular measuring device that generates two alternating voltages, with amplitude a function of the angle.
Reversal error	Deviation in reading of a position when approached from different directions (hysteresis).
ROM	"Read-Only-Memory" chip, whose memory can only be read out.
RS 422	Standardized interface for unidirectional point-to-point connections (for description refer to "Complementary"); voltage difference 7 V DC max.
RS 422/485	Interfaces for serial data transfer with specifications to EIA standards.
RS 485	Like RS 422, however as a bidirectional bus interface
Sampling frequency	Number of signal periods per second. The maximum sampling frequency limits the speed of incremental measuring systems.
SDO	Service data object (in CAN networks)
Sense	The Sense lines (Sense VCC and Sense GND) enable measurement of the factual encoder voltage without adulteration by voltage drop due to supply current and cable resistivity. With that e.g. supply voltage can automatically be adjusted.

Glossary of Technical Terms

Scaling	For programmable absolute shaft encoders the encoder actual value is multiplied by a scaling factor. Thus the resolution (increments per measuring distance or increments per revolution) is adaptable to the respective application.
SSI	Synchronous-serial Interface; standardized interface for serial data transfer
TPE	Thermo-plastic polyester elastomer; plastic coating of device cable
Tristate	Control input; switches the outputs either to active or to high impedance.
Two's complement	Number format for the representation of negative numbers; range of values at n bit: $-(2^n - 1) \dots 0 \dots (2^{n-1} - 1)$