

Stainless Industrial Types

The absolute encoder line ACURO® and incremental encoder line "RI" are available as stainless steel encoders under AC59 or AC61 for absolute encoders and RI59 for incremental encoder.

The absolute stainless steel encoders are available in the versions AC59 and AC61:

- AC59: drawn stainless steel housing, together with cable outlet, no access to control elements
- AC61: machined housing, possible with cable or bus cover, access to control elements (DIP switch, reset switch)

Available interfaces: SSI, BiSS, SSI-P, Parallel, Profibus, CAN layer2, CANopen, DeviceNet, Interbus

The incremental stainless steel encoder is available in the version RI59:

- RI59: drawn stainless steel housing with cable outlet

Examples of applications for stainless steel encoders:

- oil field applications
- packaging machines
- food & beverage
- ship equipment
- other offshore applications

Incremental



- Stainless steel encoder with high protection class
- High corrosion resistance
- Use in the area of food production
- Applications: packing machines, bottling machines, washing plants, mixers, cranes, hoists, marine outfitters



NUMBER OF PULSES

1 / 2 / 3 / 4 / 5 / 10 / 15 / 20 / 25 / 30 / 35 / 40 / 45 / 50 / 60 / 64 / 70 / 72 / 80 / **100** / 125 / 128 / 144 / 150 / 180 / 200 / 230 / **250** / 256 / 300 / 314 / 350 / 360 / 375 / 400 / 460 / 480 / **500** / 512 / 600 / 625 / 635 / 720 / 900 / **1000** / **1024** / 1200 / **1250** / 1500 / 1600 / 1800 / 2000 / 2048 / **2500** / 3000 / 3480 / **3600** / 3750 / 3968 / 4000 / **4096** / 4800 / **5000** / 5400 / 6000 / 7200 / 7680 / 8000 / 8192 / 9000 / 10000

Other number of pulses on request

Preferably available versions are printed in bold type.

TECHNICAL DATA mechanical

Housing diameter	58 mm
Shaft diameter	9.52 mm / 10 mm (Solid shaft)
Flange (Mounting of housing)	Square flange 63.5 mm
Protection class shaft input (EN 60529)	IP67
Protection class housing (EN 60529)	IP67
Shaft load axial / radial	40 N / 60 N
Max. speed	max. 10 000 rpm
Torque	≤ 1 Ncm
Moment of inertia	approx. 20 gcm ²
Vibration resistance (DIN EN 60068-2-6)	100 m/s ² (10 ... 2000 Hz)
Shock resistance (DIN EN 60068-2-27)	1000 m/s ² (6 ms)
Operating temperature	-10 °C ... +70 °C
Storage temperature	-25 °C ... +85 °C
Material housing	Stainless Steel
Weight	approx. 620 g
Connection	Cable, axial or radial

TECHNICAL DATA electrical

General design	as per DIN VDE 0160, protection class III, contamination level 2, overvoltage class II
Supply voltage ¹	RS422 + Sense (T): DC 5 V ±10 % RS422 + Alarm (R): ± 10% DC 5 V or DC 10 - 30 V Push-pull (K), Push-pull antivalent (I): DC 10-30 V
Max. current w/o load	40 mA (DC 5 V), 60 mA (DC 10 V), 30 mA (DC 24 V)
Max. pulse frequency	RS422: 300 kHz Push-pull: 200 kHz
Standard output versions ²	RS422 + Alarm (R): A, B, N, \bar{A} , \bar{B} , \bar{N} , \overline{Alarm} RS422 + Sense (T): A, B, N, \bar{A} , \bar{B} , \bar{N} , Sense Push-pull (K): A, B, N, \overline{Alarm} Push-pull complementary (I): A, B, N, \bar{A} , \bar{B} , \bar{N} , \overline{Alarm}

Incremental

TECHNICAL DATA electrical (continued)

Pulse width error	± max. 25° electrical
Number of pulses	1 ... 10 000
Alarm output	NPN-O.C., max. 5 mA
Pulse shape	Square wave
Pulse duty factor	1:1

¹ Pole protection with supply voltage DC 10 - 30 V

² Output description and technical data see chapter "Technical basics"

ELECTRICAL CONNECTIONS Cable PVC

Connecting cable Colour	Lead Ø	Output RS422 T and R	push-pull K and I
red	0.5 mm ²	DC 5/10 - 30 V	DC 10 - 30 V
red/yellow	0.14 mm ²	Sense V _{CC}	Sense V _{CC}
white	0.14 mm ²	Channel A	Channel A
white/brown	0.14 mm ²	Channel \bar{A}	Channel \bar{A} ¹
green	0.14 mm ²	Channel B	Channel B
green/brown	0.14 mm ²	Channel \bar{B}	Channel \bar{B} ¹
yellow	0.14 mm ²	Channel N	Channel N
yellow/brown	0.14 mm ²	Channel \bar{N}	Channel \bar{N} ¹
black	0.5 mm ²	GND	GND
black/yellow	0.14 mm ²	\bar{A} larm/Sense GND ²	\bar{A} larm
screen ³		screen ³	screen ³

¹ only push-pull complementary (I)

² depending on ordering code

³ connected with encoder housing

DIMENSIONED DRAWINGS

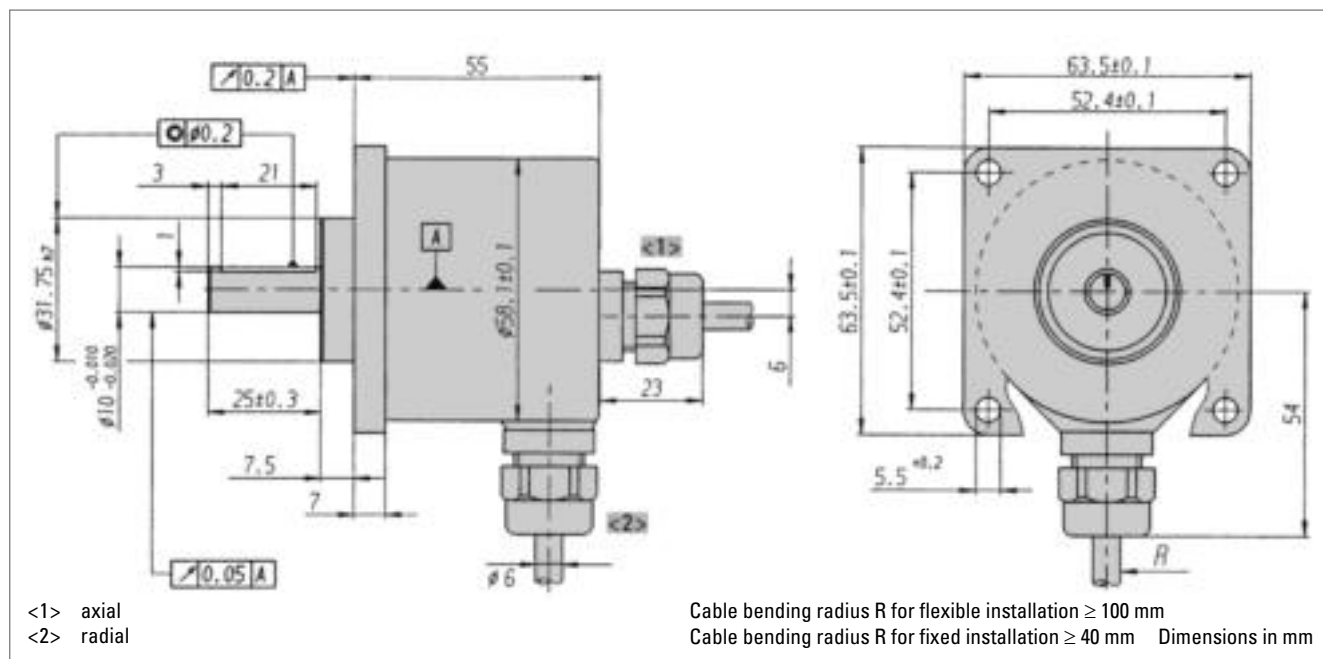

Incremental

ORDERING INFORMATION

Type	Number of pulses	Supply voltage	Flange, Protection, Shaft	Output ¹	Connection
<input type="checkbox"/>	<input type="checkbox"/>	<input type="checkbox"/>	<input type="checkbox"/>	<input type="checkbox"/>	<input type="checkbox"/>
RI59-0	1 ... 10000	A DC 5 V E DC 10 - 30 V	Q.76 Square, IP67, 9.52 mm Q.72 Square, IP67, 10 mm Q.7B Square 63.5x63.5, IP67, 9.52 x 25 mm Q.7A Square 63.5x63.5, IP67, 10 x 25 mm	R RS422 +Alarm T RS422 +Sense K Push-pull I Push-pull complementary	A PVC cable, axial B PVC cable, radial

¹ Output code "K" and "I": short-circuit-proof

ORDERING INFORMATION

Selection of cable length

Versions with cable outlet (connection A, B, E or F) are available with various lengths of cable. To order your desired cable length, please add the respective code to the end of your ordering code. Further cable lengths on request.

Code	Cable length
without code	1.5 m
-D0	3 m
-F0	5 m
-K0	10 m
-P0	15 m
-U0	20 m
-V0	25 m

ACCESSORIES

see chapter "Accessories", starting page 322

Absolute

BiSS / SSI



Version AC 59 with cable outlet

- Compact design
- Protection class IP67
- High corrosion resistance
- Robust design
- Resolution up to 29 Bit (17 Bit ST, 12 Bit MT)
- Versions with cable
- Applications: packaging machine for food and beverage, ship equipment (e.g. cranes, winches, cable laying ships), offshore applications



GENERAL INFORMATION

The absolute stainless steel encoders are available in the Versions AC 59 and AC 61

- AC 59: drawn stainless steel housing, only together with cable outlet, no access to control elements
- AC 61: machined housing, possible with cable or bus cover, access to control elements (DIP switch, Reset switch)

TECHNICAL DATA mechanical

Housing diameter	58 mm
Shaft diameter	9.52 mm / 10 mm (Solid shaft)
Flange (Mounting of housing)	Square flange 63.5 mm
Protection class shaft input (EN 60529)	IP67
Protection class housing (EN 60529)	IP67
Shaft load axial / radial	40 N / 60 N
Max. speed	max. 6000 rpm (continuous), max. 10 000 rpm (short term)
Torque	≤ 1 Ncm
Moment of inertia	approx. 20 gcm ²
Vibration resistance (DIN EN 60068-2-6)	100 m/s ² (10 ... 500 Hz)
Shock resistance (DIN EN 60068-2-27)	1000 m/s ² (6 ms)
Operating temperature	-40 °C ... +100 °C
Storage temperature	-40 °C ... +85 °C
Material shaft	Stainless Steel
Material housing	Stainless Steel
Weight	approx. 700 g with 1.5 m cable
Connection	Cable, axial or radial

TECHNICAL DATA electrical

Supply voltage	± 10% DC 5 V or DC 10 - 30 V
Max. current w/o load	50 mA (ST), 100 mA (MT)
Resolution singleturn	10 - 17 Bit Gray Excess: 360, 720 increments
Resolution multiturn	12 Bit
Output code	Binary, Gray
Drives	Clock and Data / RS422

Absolute

BiSS / SSI

TECHNICAL DATA electrical (continued)

Linearity	± ½ LSB (± 1 LSB for resolution > 13 Bit)
Incremental signals optional	Sinus-Cosinus 1 Vpp
Number of pulses	2048
3dB limiting frequency	500 kHz
Absolute accuracy	±35"
Repeatability	±7"
Parametrization	Code type, Direction, Warning, Alarm
Control inputs	Direction
Reset key	Disable via parameterization
Alarm output	Alarm bit (SSI Option), warning and alarm bit (BiSS)
Status LED	Green = ok, red = alarm

RECOMMENDED DATA TRANSFER RATE bei SSI

The max. data transfer rate depends on the cable length. For Clock / $\overline{\text{Clock}}$ and Data / $\overline{\text{Data}}$ please use twisted pairs. Use shielded cable.

Cable length	Frequency
< 50 m	< 400 kHz
< 100 m	< 300 kHz
< 200 m	< 200 kHz
< 400 m	< 100 kHz

DATA FORMAT Singleturn

Resolution	Data Bits											
		T1 ... T9	T10	T11	T12	T13	T14	T15	T16	T17	T18	T19
9 Bit ¹	S8 ... S0	0	0	0	0	0	W ²					
10 Bit ¹	S9 ... S1	S0	0	0	0	0	W ²					
11 Bit ¹	S10 ... S2	S1	S0	0	0	0	W ²					
12 Bit ¹	S11 ... S3	S2	S1	S0	0	0	W ²					
13 Bit ¹	S12 ... S4	S3	S2	S1	S0	0	W ²					
14 Bit ¹	S13 ... S5	S4	S3	S2	S1	S0	0	W ²				
15 Bit ¹	S14 ... S6	S5	S4	S3	S2	S1	S0	0	W ²			
16 Bit ¹	S15 ... S7	S6	S5	S4	S3	S2	S1	S0	0	W ²		
17 Bit ¹	S16 ... S8	S7	S6	S5	S4	S3	S2	S1	S0	0	W ²	

Examples for data format 9 Bit and 13 Bit with the optional bits alarm und parity

Resolution	Data Bits											
		T1 ... T9	T10	T11	T12	T13	T14	T15	T16	T17	T18	T19
9 Bit + P ³	S8 ... S0	0	0	0	P	0	W ²					
9 Bit + A ⁴	S8 ... S0	0	0	0	A	0	W ²					
9 Bit + P ³ + A ⁴	S8 ... S0	0	0	0	A	P	0	W ²				
9 Bit + P ³	S12 ... S4	S3	S2	S1	S0	P	0	W ²				
9 Bit + A ⁴	S12 ... S4	S3	S2	S1	S0	A	0	W ²				
9 Bit + P ³ + A ⁴	S12 ... S4	S3	S2	S1	S0	A	P	0	W ²			

Absolute

BiSS / SSI

DATA FORMAT Multiturn

Resolution	Data bits													
	T1 ... T12	T13 ... T21	T22	T23	T24	T25								
24 Bit ¹	M11 ... M0	S11 ... S2	S1	S0	0	W ²								
25 Bit ¹	M11 ... M0	S12 ... S3	S2	S1	S0	0	W ²							
26 Bit ¹	M11 ... M0	S13 ... S4	S3	S2	S1	S0	0	W ²						

Example for data format 24 Bit with the optional bits alarm und parity

24 Bit + P ³	M11 ... M0	S11 ... S2	S1	S0	P	0	W ²							
24 Bit + A ⁴	M11 ... M0	S11 ... S2	S1	S0	A	0	W ²							
24 Bit + P ³ + A ⁴	M11 ... M0	S11 ... S2	S1	S0	A	P	0	W ²						

S0 ... S16 Data bits for resolution per revolution

M0 ... M11 Data bits for number of revolutions (only for multiturn)

¹ Options (Parity bit, alarm and parity bit, zero bit) on request

²W: from this data bit on the data iteration for multiplex starts

³ Parity bit: Even Parity (The parity bit expands the data bits to an even number of 1-bits).
(Option)

⁴ Alarm bit: is set to "1" when over temperature, under temperature, disc breakage and defect LED

SYNCHRONOUS-SERIAL TRANSFER (SSI)

Synchronous readout of the encoder data is according to the clock rate given by the SSI-counterpart.

The number of clock rates is determined by the type of encoder (singleturn resp. multiturn) and the configuration of the special Bits as defined.

For multiple transactions (the stored value is readout several times successively) a fixed clock rate per transaction must be kept (for singleturn 13 resp. 14 clocks, for multiturn 25 resp. 26 clocks).

- In the rest position, when the last clock brush has passed by more than 30µs, the data output is logically at "1".
- With the first descending clock edge the encoder data and the special bits are

loaded in the shift register of the encoder interface.

- With each ascending clock edge the data bits are serially readout, beginning with the MSB.
- At the end of the data transfer the data output is set to logically "0" for approx. 20µs. If within these 20µs a further clock brush reaches the encoder interface, the already transferred data is readout once again. This multiple transfer of the same data makes it possible to recognize transfer errors.
- After the 20µs the data output goes to its rest position, logically "1". Subsequently new encoder data can be readout.

Absolute

BiSS / SSI

ELECTRICAL CONNECTIONS

12 pole / cable
Interface SC, BC

Cable	Signal
brown ²	0 V (supply voltage)
pink	Data
yellow	Clock
white/green	A+
blue	$\overline{\text{Direction}}$ ¹
red/blue	B+
brown/green	A-
white ²	DC 5/10 - 30 V
grey/pink	B-
grey	$\overline{\text{Data}}$
green	$\overline{\text{Clock}}$
black	Sense

¹ $\overline{\text{Direction}}$: +UB or unconnected = ascending code values with rotation cw
0 V = descending code values with rotation cw

² use only the thin wires ($\varnothing = 0,14$ mm)

DIMENSIONED DRAWINGS

see chapter "Dimensioned drawings AC 59 / AC 61", starting page 232

ORDERING INFORMATION

Type	Resolution ^{1,2}	Supply voltage	Flange, Protection, Shaft	Interface	Connection
<input type="checkbox"/>	<input type="text"/>	<input type="checkbox"/>	<input type="checkbox"/>	<input type="checkbox"/>	<input type="checkbox"/>
AC59	0010 10 Bit ST 0012 12 Bit ST 0013 13 Bit ST 0014 14 Bit ST 0017 17 Bit ST 0360 360 increments ST 0720 720 increments ST 1212 12 Bit MT + 12 Bit ST 1213 12 Bit MT + 13 Bit ST 1214 12 Bit MT + 14 Bit ST (BiSS) 1217 12 Bit MT + 17 Bit ST (BiSS)	A DC 5 V E DC 10 - 30 V	0.76 Square, IP67, 9.52 mm 0.72 Square, IP67, 10 mm	BI BiSS BC BiSS (+SinCos 1Vpp) SB SSI binary SG SSI Gray SC SSI Gray (+SinCos 1Vpp)	A Cable, axial B Cable, radial

¹ Resolution 360 increments ST with Offset 76 (value range 76...435)

² Resolution 720 increments ST with Offset 152 (value range 152...871)

Absolute**BiSS / SSI****ORDERING INFORMATION****Selection of cable length**

Versions with cable outlet (connection A, B, E or F) are available with various lengths of cable. To order your desired cable length, please add the respective code to the end of your ordering code. Further cable lengths on request.

Code	Cable length
without code	1.5 m
-D0	3 m
-F0	5 m
-K0	10 m
-P0	15 m
-U0	20 m
-V0	25 m

ACCESSORIES

see chapter "Accessories", starting page 322

Absolute

Parallel



Version AC 59 with cable outlet



Version AC 61 with bus cover

- Compact design
- Protection class IP67
- High corrosion resistance
- Robust design
- Resolution up to 26 Bit (14 Bit ST, 12 Bit MT)
- Gray or Binary code
- Encoder monitoring
- Output Tristate short circuit-proof
- Applications: packaging machine for food and beverage, ship equipment (e.g. cranes, winches, cable laying ships), offshore applications



GENERAL INFORMATION

The absolute stainless steel encoders with parallel interface are available in the Versions AC 59 and AC 61.

- AC 59: drawn stainless steel housing, only together with Singleturn
- AC 61: machined housing

TECHNICAL DATA mechanical

Housing diameter	AC 59: 58 mm AC 61: 61.5 mm
Shaft diameter	9.52 mm / 10 mm (Solid shaft)
Flange (Mounting of housing)	Square flange 63.5 mm
Protection class shaft input (EN 60529)	IP67
Protection class housing (EN 60529)	IP67
Shaft load axial / radial	40 N / 60 N
Max. speed	max. 6000 rpm (continuous), max. 10 000 rpm (short term)
Torque	≤ 1 Ncm
Moment of inertia	approx. 20 gcm ²
Vibration resistance (DIN EN 60068-2-6)	100 m/s ² (10 ... 500 Hz)
Shock resistance (DIN EN 60068-2-27)	1000 m/s ² (6 ms)
Operating temperature	-40 °C ... +100 °C
Storage temperature	-40 °C ... +85 °C
Material shaft	Stainless Steel
Material housing	Stainless Steel
Weight	AC 59: approx. 700 g with 1.5 m cable AC 61: approx. 980 g with 1.5 m cable
Connection	Cable, axial or radial

Absolute

Parallel

TECHNICAL DATA electrical

Supply voltage	DC 10-30 V On request: DC 5 V
Max. current w/o load	200 mA (ST), 300 mA (MT)
Resolution singleturn	10 - 14 Bit Gray Excess: 360, 720 increments
Resolution multiturn	12 Bit
Output code	Binary, Gray, Gray Excess
Linearity	$\pm \frac{1}{2}$ LSB
Output current	30 mA per Bit, short-circuit-proof
Control inputs	$\overline{\text{Latch}}$, $\overline{\text{Direction}}$, $\overline{\text{Tristate}}$ with ST, $\overline{\text{Tristate}}$ with MT
Alarm output	NPN-O.C., max. 5 mA
Status LED	Green = ok, red = alarm

Note: preset key only with MT (IP64), preset value = 0

Data output level

Supply voltage U_B	DC 5 V - 5 % +10 % ¹	DC 10 - 30 V
Output level High	≥ 3.5 V (30 mA) ≥ 3.9 V (10 mA)	$\geq U_B - 2.2$ V (30 mA) $\geq U_B - 1.8$ V (10 mA)
Output level Low	≤ 1.6 V (30 mA) ≤ 1.2 V (10 mA)	≤ 1.6 V (30 mA) ≤ 1.2 V (10 mA)
Rise time (1.5 m Cable)	≤ 0.1 μ s	≤ 0.2 μ s
Drop time (1.5 m Cable)	≤ 0.05 μ s	≤ 0.1 μ s

¹ on request

Control inputs

Input	Level logical (physical)	Function
$\overline{\text{Direction}}$	1 (+ U_B or open) 0 (0 V)	ascending code values when turning clockwise (cw) descending code values when turning clockwise (cw)
$\overline{\text{Latch}}$	1 (+ U_B or open) 0 (0 V)	encoder data continuously changing at output encoder data stored and constant at output
$\overline{\text{Tristate}}$ (with singleturn)	1 (+ U_B or open) 0 (0 V)	outputs active outputs at high impedance (Tristate mode)
$\overline{\text{Tristate}}$ (with multiturn)	1 (+ U_B) 0 (0 V or open)	outputs at high impedance (Tristate mode) outputs active

Typical actuating delay time 10 μ s with push-pull selection; when selected via O.C., an external pull-down resistor (1 K Ω) is required

Absolute

Parallel

ELECTRICAL CONNECTIONS

Singleturn, cable

Colour (PVC)	9 Bit / 360 incr.	10 Bit / 720 incr.	12 Bit	13 Bit	14 Bit
grey/pink	N.C.	N.C.	N.C.	N.C.	S0 (LSB)
brown/yellow	N.C.	N.C.	N.C.	S0 (LSB)	S1
brown/grey	N.C.	N.C.	S0 (LSB)	S1	S2
red/blue	N.C.	N.C.	S1	S2	S3
violet	N.C.	S0 (LSB)	S2	S3	S4
white/brown	S0 (LSB)	S1	S3	S4	S5
white/green	S1	S2	S4	S5	S6
white/yellow	S2	S3	S5	S6	S7
white/grey	S3	S4	S6	S7	S8
white/pink	S4	S5	S7	S8	S9
white/blue	S5	S6	S8	S9	S10
white/red	S6	S7	S9	S10	S11
white/black	S7	S8	S10	S11	S12
brown/green	S8 (MSB)	S9 (MSB)	S11 (MSB)	S12 (MSB)	S13 (MSB)
yellow	$\overline{\text{Tristate S0...S8}}$	$\overline{\text{Tristate S0...S9}}$	$\overline{\text{Tristate S0...S11}}$	$\overline{\text{Tristate S0...S12}}$	$\overline{\text{Tristate S0...S13}}$
pink	$\overline{\text{Latch}}$	$\overline{\text{Latch}}$	$\overline{\text{Latch}}$	$\overline{\text{Latch}}$	$\overline{\text{Latch}}$
green	$\overline{\text{Direction}}$	$\overline{\text{Direction}}$	$\overline{\text{Direction}}$	$\overline{\text{Direction}}$	$\overline{\text{Direction}}$
black	0 V	0 V	0 V	0 V	0 V
red	DC 5 V/ 10-30 V	DC 5 V/ 10-30 V	DC 5 V/ 10-30 V	DC 5 V/ 10-30 V	DC 5 V/ 10-30 V
brown	$\overline{\text{Alarm}}$	$\overline{\text{Alarm}}$	$\overline{\text{Alarm}}$	$\overline{\text{Alarm}}$	$\overline{\text{Alarm}}$

ELECTRICAL CONNECTIONS

Multiturn, cable (only AC 61 - Parallel)

10 cm cable with Sub-D connector, 37 pole			10 cm cable with Sub-D connector, 37 pole		
Cable (TPE)	Pin	Connection	Cable (TPE)	Pin	Connection
brown	2	S0	white/blue	14	M4 ¹
green	21	S1	brown/blue	33	M5 ¹
yellow	3	S2	white/red	15	M6 ¹
grey	22	S3	brown/red	34	M7 ¹
pink	4	S4	white/black	16	M8 ²
violet	23	S5	brown/black	35	M9 ²
grey/pink	5	S6	grey/green	17	M10 ²
red/blue	24	S7	yellow/grey	36	M11 ²
white/green	6	S8	pink/green	18	Alarm
brown/green	25	S9	yellow/pink	10	Direction
white/yellow	7	S10	green/blue	30	Latch
yellow/brown	26	S11	yellow/blue	12	Tristate
white/grey	8	M0	red (0.5mm ²)	13	DC 10-30 V
grey/brown	27	M1	white (0.5mm ²)	31	DC 10-30 V
white/pink	9	M2	blue (0.5mm ²)	1	0 V
pink/brown	28	M3	black (0.5mm ²)	20	0 V

¹ N. C. with resolution 16 Bit (4 Bit MT)

² N. C. with resolution 16 Bit or 20 Bit (4 or 8 Bit MT)

DIMENSIONED DRAWINGS

see chapter "Dimensioned drawings AC 59 / AC 61", starting page 232

ORDERING INFORMATION

Type	Resolution ^{1,2,3}	Supply voltage	Flange, Protection, Shaft	Interface	Connection
<input type="checkbox"/>	<input type="text"/>	<input type="checkbox"/>	<input type="checkbox"/>	<input type="checkbox"/>	<input type="checkbox"/>
AC59 AC61	0010 10 Bit ST 0012 12 Bit ST 0013 13 Bit ST 0014 14 Bit ST 0017 17 Bit ST 0360 360 increments ST 0720 720 increments ST 0412 4 Bit MT + 12 Bit ST (AC 61) 0812 8 Bit MT + 12 Bit ST (AC 61) 1212 12 Bit MT + 12 Bit ST (AC 61)	A DC 5 V E DC 10 - 30 V	Q.76 Square, IP67, 9.52 mm Q.72 Square, IP67, 10 mm	PB Parallel binary PG Parallel Gray	A Cable, axial B Cable, radial

¹ Resolution 360 increments ST with Offset 76 (value range 76...435)

² Resolution 720 increments ST with Offset 152 (value range 152...871)

³ AC59 only with ST (only AC 59)

ORDERING INFORMATION

Selection of cable length

Versions with cable outlet (connection A, B, E or F) are available with various lengths of cable. To order your desired cable length, please add the respective code to the end of your ordering code. Further cable lengths on request.

Code	Cable length
without code	1.5 m
-D0	3 m
-F0	5 m
-K0	10 m
-P0	15 m
-U0	20 m
-V0	25 m

ACCESSORIES

see chapter "Accessories", starting page 322

Absolute

Profibus



Version AC 61 with bus cover

- Compact design
- Protection class IP67
- High corrosion resistance
- Robust design
- Resolution up to 26 Bit (14 Bit ST, 12 Bit MT)
- Bus cover
- Programmable: Resolution, Preset, Direction
- Output of speed, acceleration
- Applications: packaging machine for food and beverage, ship equipment (e.g. cranes, winches, cable laying ships), offshore applications



GENERAL INFORMATION

The absolute stainless steel encoders are available in the Versions AC 59 and AC 61.

- AC 59: drawn stainless steel housing, only together with cable outlet, no access to control elements
- AC 61: machined housing, possible with cable or bus cover, access to control elements (DIP switch, Reset switch)

TECHNICAL DATA mechanical

Housing diameter	61.5 mm
Shaft diameter	9.52 mm / 10 mm (Solid shaft)
Flange (Mounting of housing)	Square flange 63.5 mm
Protection class shaft input (EN 60529)	IP67
Protection class housing (EN 60529)	IP67
Shaft load axial / radial	40 N / 60 N
Max. speed	max. 6000 rpm (continuous), max. 10 000 rpm (short term)
Torque	≤ 1 Ncm
Moment of inertia	approx. 20 gcm ²
Vibration resistance (DIN EN 60068-2-6)	100 m/s ² (10 ... 500 Hz)
Shock resistance (DIN EN 60068-2-27)	1000 m/s ² (6 ms)
Operating temperature	-40 °C ... +85 °C
Storage temperature	-40 °C ... +85 °C
Material shaft	Stainless Steel
Material housing	Stainless Steel
Weight	approx. 1180 g
Connection	Bus cover with 3 sealed cable exits

TECHNICAL DATA electrical

General design	as per DIN EN 61010-1, protection class III, contamination level 2, overvoltage class II
Supply voltage	DC 10-30 V
Max. current w/o load	220 mA (ST), 250 mA (MT)
EMC	EN 61326: Class A
Resolution singleturn	10 - 14 Bit

Absolute

Profibus

TECHNICAL DATA electrical (continued)

Resolution multiturn	12 Bit
Output code	Binary
Drives	RS 485
Linearity	$\pm \frac{1}{2}$ LSB (± 1 LSB for resolution 13, 14, 25, 26 Bit)
Profile/ protocol	Profibus DP with encoder profile class C2 (parameterizable)
Programmable	Resolution, Preset, Direction
Integrated special functions	Speed, Acceleration, Operating time
Baud rate	is automatically set within a range of 9.6 KBaud through 12 MBaud
Device address	adjustable with DIP switches, via fieldbus (optional)
Bus termination resistor	set via DIP switches

STARTUP (The encoder can be easily and quickly installed and programmed with the GSD file.)

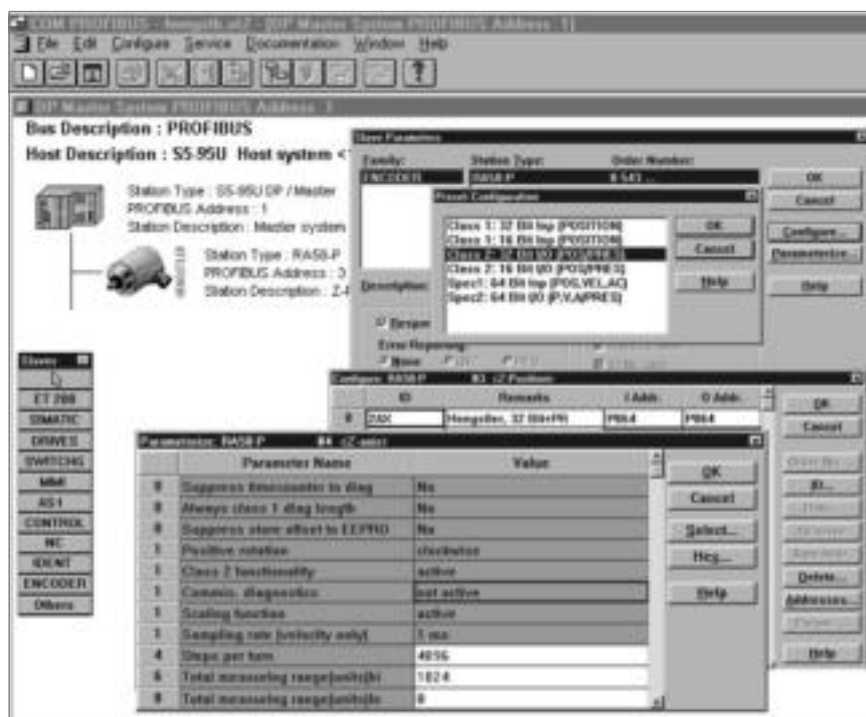

ELECTRICAL CONNECTIONS Bus cover with 3 sealed cable exits

Connecting Terminal	Signal
1	UB in (DC 10 - 30V)
2	0 V in
3	UB out
4	0 V out
5	B in
6	A in
7	B out
8	A out

DIMENSIONED DRAWINGS

see chapter "Dimensioned drawings AC 59 / AC 61", starting page 232

ORDERING INFORMATION

Type	Resolution	Supply voltage	Flange, Protection, Shaft	Interface	Connection
<input type="checkbox"/>	<input type="checkbox"/>	<input type="checkbox"/>	<input type="checkbox"/>	<input type="checkbox"/>	<input type="checkbox"/>
AC61	0010 10 Bit ST 0012 12 Bit ST 0013 13 Bit ST 0014 14 Bit ST 1212 12 Bit MT + 12 Bit ST 1213 12 Bit MT + 13 Bit ST 1214 12 Bit MT + 14 Bit ST	E DC 10 - 30 V	Q.76 Square, IP67, 9.52 mm Q.72 Square, IP67, 10 mm	DP Profibus	Z Bus cover with 3 sealed cable exits

ACCESSORIES

see chapter "Accessories", starting page 322

Absolute

CANopen



Version AC 61 with bus cover

- Compact design
- Protection class IP67
- High corrosion resistance
- Robust design
- Resolution up to 28 Bit (16 Bit ST, 12 Bit MT)
- Versions with cable or demountable bus cover
- Programmable: Resolution, Preset, Offset, Direction
- Output of speed, acceleration
- Applications: packaging machine for food and beverage, ship equipment (e.g. cranes, winches, cable laying ships), offshore applications



GENERAL INFORMATION

The absolute stainless steel encoders are available in the Versions AC 59 and AC 61.

- AC 59: drawn stainless steel housing, only together with cable outlet, no access to control elements
- AC 61: machined housing, possible with cable or bus cover, access to control elements (DIP switch, Reset switch)

TECHNICAL DATA mechanical

Housing diameter	61.5 mm
Shaft diameter	9.52 mm / 10 mm (Solid shaft)
Flange (Mounting of housing)	Square flange 63.5 mm
Protection class shaft input (EN 60529)	IP67
Protection class housing (EN 60529)	IP67
Shaft load axial / radial	40 N / 60 N
Max. speed	max. 6000 rpm (continuous), max. 10 000 rpm (short term)
Torque	≤ 1 Ncm
Moment of inertia	approx. 20 gcm ²
Vibration resistance (DIN EN 60068-2-6)	100 m/s ² (10 ... 500 Hz)
Shock resistance (DIN EN 60068-2-27)	1000 m/s ² (6 ms)
Operating temperature	-40 °C ... +85 °C
Storage temperature	-40 °C ... +85 °C
Material shaft	Stainless Steel
Material housing	Stainless Steel
Weight	approx. 980 g with 1.5 m cable / 1180 g with bus cover
Connection	Cable, axial or radial Bus cover with 3 sealed cable exits

TECHNICAL DATA electrical

General design	as per DIN EN 61010-1, protection class III, contamination level 2, overvoltage class II
Supply voltage	DC 10-30 V
Max. current w/o load	220 mA (ST), 250 mA (MT)
EMC	EN 61326: Class A

Absolute

CANopen

TECHNICAL DATA electrical (continued)

Resolution singleturn	10 - 16 Bit
Resolution multiturn	12 Bit
Output code	Binary
Linearity	$\pm \frac{1}{2}$ LSB (± 1 LSB for resolution 13, 14, 25, 26 Bit)
Profile/ protocol	CANopen according to DS 301 with profile DSP 406, programmable encoder according class C2
Programmable	Resolution, Preset, Offset, Direction
Integrated special functions	Speed, Acceleration, Limit values, Operating time
Baud rate	set via DIP switches within a range of 10 through 1000 Kbit/s
Bus termination resistor	set via DIP switches
Updating of values	every millisecond (adjustable), on request
Basic identifier	set via DIP switches

ELECTRICAL CONNECTIONS 12 pole / cable

TPE cable	Cable pairs	Signal
yellow	Pair 1	CAN in+
green		CAN in -
pink	Pair 2	CAN out+
grey		CAN out -
blue		CAN GND in
brown		CAN GND out
white	Pair 3	UB in
brown		0 V in
screen	screen	screen

ELECTRICAL CONNECTIONS Bus cover with 3 sealed cable exits

Connecting block KL 1 (10 pole)	
No.	Signal name
1	UB in (DC 10-30V)
2	0 V in
3	CAN in - (dominant L)
4	CAN in + (dominant H)
5	CAN GND in
6	CAN GND out
7	CAN out + (dominant H)
8	CAN out - (dominant L)
9	0 V out
10	UB out (DC 10-30V)

DIMENSIONED DRAWINGS

see chapter "Dimensioned drawings AC 59 / AC 61", starting page 232

ORDERING INFORMATION

Type	Resolution	Supply voltage	Flange, Protection, Shaft	Interface	Connection
<input type="checkbox"/>	<input type="checkbox"/>	<input type="checkbox"/>	<input type="checkbox"/>	<input type="checkbox"/>	<input type="checkbox"/>
AC61	0010 10 Bit ST 0012 12 Bit ST 0013 13 Bit ST 0014 14 Bit ST 0016 16 Bit ST 1212 12 Bit MT + 12 Bit ST 1213 12 Bit MT + 13 Bit ST 1214 12 Bit MT + 14 Bit ST 1216 12 Bit MT + 16 Bit ST	E DC 10 - 30 V	0.76 Square, IP67, 9.52 mm 0.72 Square, IP67, 10 mm	OL CANopen	A Cable, axial B Cable, radial Z Bus cover with 3 sealed cable exits

ORDERING INFORMATION

Selection of cable length

Versions with cable outlet (connection A, B, E or F) are available with various lengths of cable. To order your desired cable length, please add the respective code to the end of your ordering code. Further cable lengths on request.

Code	Cable length
without code	1.5 m
-D0	3 m
-F0	5 m
-K0	10 m
-P0	15 m
-U0	20 m
-V0	25 m

ACCESSORIES

see chapter "Accessories", starting page 322

Absolute

CANlayer2



Version AC 61 with bus cover

- Compact design
- Protection class IP67
- High corrosion resistance
- Robust design
- Resolution up to 26 Bit (14 Bit ST, 12 Bit MT)
- Versions with cable or demountable bus cover
- Applications: packaging machine for food and beverage, ship equipment (e.g. cranes, winches, cable laying ships), offshore applications



GENERAL INFORMATION

The absolute stainless steel encoders are available in the Versions AC 59 and AC 61.

- AC 59: drawn stainless steel housing, only together with cable outlet, no access to control elements
- AC 61: machined housing, possible with cable or bus cover, access to control elements (DIP switch, Reset switch)

TECHNICAL DATA mechanical

Housing diameter	61.5 mm
Shaft diameter	9.52 mm / 10 mm (Solid shaft)
Flange (Mounting of housing)	Square flange 63.5 mm
Protection class shaft input (EN 60529)	IP67
Protection class housing (EN 60529)	IP67
Shaft load axial / radial	40 N / 60 N
Max. speed	max. 6000 rpm (continuous), max. 10 000 rpm (short term)
Torque	≤ 1 Ncm
Moment of inertia	approx. 20 gcm ²
Vibration resistance (DIN EN 60068-2-6)	100 m/s ² (10 ... 500 Hz)
Shock resistance (DIN EN 60068-2-27)	1000 m/s ² (6 ms)
Operating temperature	-40 °C ... +85 °C
Storage temperature	-40 °C ... +85 °C
Material shaft	Stainless Steel
Material housing	Stainless Steel
Weight	approx. 980 g with 1.5 m cable / 1180 g with bus cover
Connection	Cable, axial or radial Bus cover with 3 sealed cable exits

TECHNICAL DATA electrical

General design	as per DIN EN 61010-1, protection class III, contamination level 2, overvoltage class II
Supply voltage	DC 10-30 V
Max. current w/o load	220 mA (ST), 250 mA (MT)
EMC	EN 61326: Class A
Resolution singleturn	10 - 14 Bit
Resolution multiturn	12 Bit

Absolute

CANlayer2

TECHNICAL DATA
electrical (continued)

Output code	Binary
Linearity	$\pm 1/2$ LSB (± 1 LSB for resolution 13, 14, 25, 26 Bit)
Profile/ protocol	CAN 2.0 A
Programmable	Direction, Limit values
Baud rate	set via DIP switches within a range of 10 through 1000 Kbit/s
Bus termination resistor	set via DIP switches
Updating of values	every millisecond
Basic identifier	set via DIP switches

ELECTRICAL CONNECTIONS
12 pole / cable

TPE cable	Cable pairs	Signal
yellow	Pair 1	CAN in+
green		CAN in -
pink	Pair 2	CAN out+
grey		CAN out -
blue		CAN GND in
brown		CAN GND out
white	Pair 3	UB in
brown		0 V in
screen	screen	screen

ELECTRICAL CONNECTIONS
Bus cover with 3 sealed cable exits

Connecting block KL 1 (10 pole)	
No.	Signal name
1	UB in (DC 10-30V)
2	0 V in
3	CAN in - (dominant L)
4	CAN in + (dominant H)
5	CAN GND in
6	CAN GND out
7	CAN out + (dominant H)
8	CAN out - (dominant L)
9	0 V out
10	UB out (DC 10-30V)

DIMENSIONED DRAWINGS

see chapter "Dimensioned drawings AC 59 / AC 61", starting page 232

ORDERING INFORMATION

Type	Resolution	Supply voltage	Flange, Protection, Shaft	Interface	Connection
<input type="checkbox"/>	<input type="checkbox"/>	<input type="checkbox"/>	<input type="checkbox"/>	<input type="checkbox"/>	<input type="checkbox"/>
AC61	0010 10 Bit ST 0012 12 Bit ST 0013 13 Bit ST 0014 14 Bit ST 1212 12 Bit MT + 12 Bit ST 1213 12 Bit MT + 13 Bit ST 1214 12 Bit MT + 14 Bit ST	E DC 10 - 30 V	0.76 Square, IP67, 9.52 mm 0.72 Square, IP67, 10 mm	CL CANLayer2	A Cable, axial B Cable, radial Z Bus cover with 3 sealed cable exits

ORDERING INFORMATION Selection of cable length

Versions with cable outlet (connection A, B, E or F) are available with various lengths of cable. To order your desired cable length, please add the respective code to the end of your ordering code. Further cable lengths on request.

Code	Cable length
without code	1.5 m
-D0	3 m
-F0	5 m
-K0	10 m
-P0	15 m
-U0	20 m
-V0	25 m

ACCESSORIES

see chapter "Accessories", starting page 322

Absolute

DeviceNet



Version AC 61 with bus cover

- Compact design
- Protection class IP67
- High corrosion resistance
- Robust design
- Resolution up to 26 Bit (14 Bit ST, 12 Bit MT)
- Bus cover
- Programmable: Resolution, Preset, Direction
- Allan-Bradley compatible
- Applications: packaging machine for food and beverage, ship equipment (e.g. cranes, winches, cable laying ships), offshore applications



GENERAL INFORMATION

The absolute stainless steel encoders are available in the Versions AC 59 and AC 61.

- AC 59: drawn stainless steel housing, only together with cable outlet, no access to control elements
- AC 61: machined housing, possible with cable or bus cover, access to control elements (DIP switch, Reset switch)

TECHNICAL DATA
mechanical

Housing diameter	61.5 mm
Shaft diameter	9.52 mm / 10 mm (Solid shaft)
Flange (Mounting of housing)	Square flange 63.5 mm
Protection class shaft input (EN 60529)	IP67
Protection class housing (EN 60529)	IP67
Shaft load axial / radial	40 N / 60 N
Max. speed	max. 6000 rpm (continuous), max. 10 000 rpm (short term)
Torque	≤ 1 Ncm
Moment of inertia	approx. 20 gcm ²
Vibration resistance (DIN EN 60068-2-6)	100 m/s ² (10 ... 500 Hz)
Shock resistance (DIN EN 60068-2-27)	1000 m/s ² (6 ms)
Operating temperature	-40 °C ... +85 °C
Storage temperature	-40 °C ... +85 °C
Material shaft	Stainless Steel
Material housing	Stainless Steel
Weight	approx. 1180 g
Connection	Bus cover with 2 sealed cable exits

TECHNICAL DATA
electrical

General design	as per DIN EN 61010-1, protection class III, contamination level 2, overvoltage class II
Supply voltage	DC 10-30 V
Max. current w/o load	220 mA (ST), 250 mA (MT)
EMC	Noise emission according to EN 50081-2 Immunity to interference according to EN 50082-2

Absolute

DeviceNet

TECHNICAL DATA electrical (continued)

EMC	EN 61326: Class A
Resolution singleturn	10 - 14 Bit
Resolution multiturn	12 Bit
Output code	Binary
Interface	CAN High-Speed according to ISO/DIS 11898 CAN specification 2.0 A (11-Bit-Identifier)
Linearity	$\pm \frac{1}{2}$ LSB (± 1 LSB for resolution 13, 14, 25, 26 Bit)
Profile/ protocol	DeviceNet according to Rev. 2.0, programmable encoder
Programmable	Resolution, Preset, Direction
Baud rate	set via DIP switches to 125, 250, 500 Kbaud
Bus termination resistor	set via DIP switches
Updating of values	every 5 Milliseconds
MAC-ID	set via DIP switches

RECOMMENDED DATA TRANSFER Lead type A

Shaft resistance	135...165 Ω (3...20MHz)
Operating capacity	< 30pF/m
Loop impedance	< 110 Ω /km
Strand diameter	> 0.64 mm
Strand cross section	> 0.34 mm ²

Transfer speeds

Segment length	kbit/s
500 m	125
250 m	250
100 m	500

STARTUP (the encoder can be easily and quickly installed and programmed with the EDS file)



Absolute

DeviceNet

ELECTRICAL CONNECTIONS
 Bus cover with 2 sealed cable exits

Terminals	
No.	Signal name
1	UB in (DC 10 - 30V)
2	0 V in
3	CAN-L
4	CAN-H
5	DRAIN
6	DRAIN
7	DRAIN
8	CAN-L
9	0 V out
10	UB out (DC 10 - 30V)

DIMENSIONED DRAWINGS

see chapter "Dimensioned drawings AC 59 / AC 61", starting page 232

ORDERING INFORMATION

Type	Resolution	Supply voltage	Flange, Protection, Shaft	Interface	Connection
<input type="checkbox"/>	<input type="text"/>	<input type="checkbox"/>	<input type="text"/>	<input type="checkbox"/>	<input type="checkbox"/>
AC61	0010 10 Bit ST 0012 12 Bit ST 0013 13 Bit ST 0014 14 Bit ST 1212 12 Bit MT + 12 Bit ST 1213 12 Bit MT + 13 Bit ST 1214 12 Bit MT + 14 Bit ST	E DC 10 - 30 V	0.76 Square, IP67, 9.52 mm 0.72 Square, IP67, 10 mm	VD DeviceNet	Z Bus cover with 2 sealed cable exits

ACCESSORIES

see chapter "Accessories", starting page 322

Absolute

Interbus



Version AC 61 with bus cover

- Compact design
- Protection class IP67
- High corrosion resistance
- Robust design
- Resolution up to 24 Bit (12 Bit ST, 12 Bit MT)
- Resolution programmable
- Preset (K3)
- Direction (K3)
- Bus cover
- Applications: packaging machine for food and beverage, ship equipment (e.g. cranes, winches, cable laying ships), offshore applications



GENERAL INFORMATION

The absolute stainless steel encoders are available in the Versions AC 59 and AC 61.

- AC 59: drawn stainless steel housing, only together with cable outlet, no access to control elements
- AC 61: machined housing, possible with cable or bus cover, access to control elements (DIP switch, Reset switch)

TECHNICAL DATA mechanical

Housing diameter	61.5 mm
Shaft diameter	9.52 mm / 10 mm (Solid shaft)
Flange (Mounting of housing)	Square flange 63.5 mm
Protection class shaft input (EN 60529)	IP67
Protection class housing (EN 60529)	IP67
Shaft load axial / radial	40 N / 60 N
Max. speed	max. 6000 rpm (continuous), max. 10 000 rpm (short term)
Torque	≤ 1 Ncm
Moment of inertia	approx. 20 gcm ²
Vibration resistance (DIN EN 60068-2-6)	100 m/s ² (10 ... 500 Hz)
Shock resistance (DIN EN 60068-2-27)	1000 m/s ² (6 ms)
Operating temperature	-40 °C ... +70 °C
Storage temperature	-40 °C ... +85 °C
Material shaft	Stainless Steel
Material housing	Stainless Steel
Weight	approx. 1180 g
Connection	Bus cover with 3 sealed cable exits

TECHNICAL DATA electrical

General design	as per DIN EN 61010-1, protection class III, contamination level 2, overvoltage class II
Supply voltage	DC 10-30 V
Max. current w/o load	220 mA (ST, recommended external fuse: T 0.25 A), 250 mA (MT, recommended external fuse: T 0.25 A)

Absolute

Interbus

TECHNICAL DATA electrical (continued)

EMC	Noise emission according to EN 50081-2 Immunity to interference according to EN 50082-2
Resolution singleturn	10 - 12 Bit
Resolution multiturn	12 Bit
Output code	32 Bit binary
Linearity	$\pm \frac{1}{2}$ LSB
Profile/ protocol	ENCOM-Profil K3 = ID-Code 37, K2 = ID-Code 36
Programmable	Resolution, Preset, Offset, Direction
Output current ¹	max. 4.5 A for bus cover with 2x M23 (recommended external fuse: T 4.5 A) max. 2 A for all other connections (recommended external fuse: T 2 A)
Baud rate	500 KBaud
Updating of values	every 600 μ s

¹ Current with looped through voltage supply

DATA FORMAT Interbus K2/K3

	Differential signals (RS485) ENCOM profile K3, K2, 32 Bit, binary process data				
Data format	S μ pi-address	0	1	2	3
(as per Phoenix)	Byte-No.	3	2	1	0
ID-Code K2	36H (= 54 decimal)				
ID-Code K3	37H (= 55 decimal)				

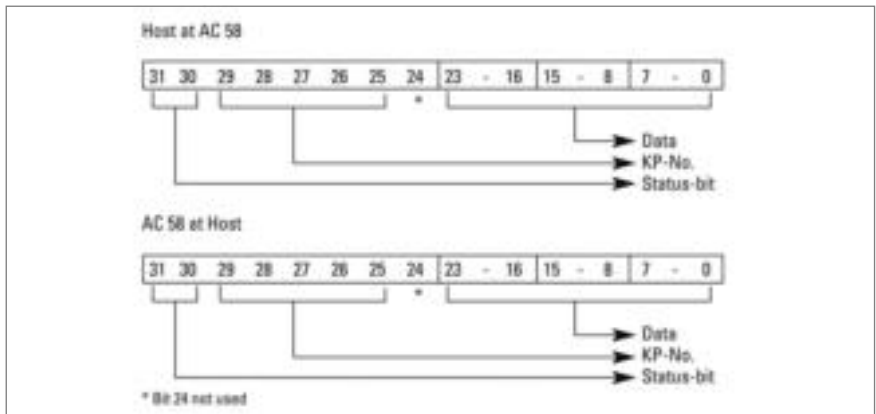

PROGRAMMABLE FUNKTIONS for Interbus K3

Function (Programming directly via the bus through transfer of configuration parameters)	Preset values (manufacturer's standard settings)	Customer-specific parameters
Code sequence for clockwise (cw) rotation	ascending	
Offset (KP-No. 05)	0	
Preset value (KP-No. 04)	0	
Scaling faktor (KP-No. 08)	1 ¹	

¹ maximum resolution

Absolute

Interbus

ELECTRICAL CONNECTIONS

Bus cover with 3 sealed cable exits

Connection clamp (12 pole)

1	UB +
2	GND
3	DI1+
4	DI1-
5	D01+
6	D01-
7	D02+
8	D02-
9	DI2+
10	DI2-
11	RBST
12	GND

DIMENSIONED DRAWINGS

see chapter "Dimensioned drawings AC 59 / AC 61", starting page 232

ORDERING INFORMATION

Type	Resolution	Supply voltage	Flange, Protection, Shaft	Interface	Connection
<input type="checkbox"/>	<input type="text"/>	<input type="checkbox"/>	<input type="text"/>	<input type="checkbox"/>	<input type="checkbox"/>
AC61	0010 10 Bit ST 0012 12 Bit ST 0013 13 Bit ST 0014 14 Bit ST 1212 12 Bit MT + 12 Bit ST 1213 12 Bit MT + 13 Bit ST 1214 12 Bit MT + 14 Bit ST	E DC 10 - 30 V	Q.76 Square, IP67, 9.52 mm Q.72 Square, IP67, 10 mm	I2 Interbus K2 K3 Interbus K3	Z Bus cover with 3 sealed cable exits

ACCESSORIES

see chapter "Accessories", starting page 322

Absolute

SSI programmable

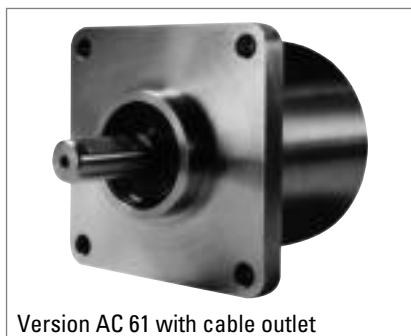

Version AC 61 with cable outlet

- Compact design
- Protection class IP67
- High corrosion resistance
- Robust design
- Resolution up to 29 Bit (17 Bit ST, 12 Bit MT)
- Versions with cable
- Parameterization: Resolution, code type, direction, output format, warning, alarm
- Applications: packaging machine for food and beverage, ship equipment (e.g. cranes, winches, cable laying ships), offshore applications



GENERAL INFORMATION

The absolute stainless steel encoders are available in the Versions AC 59 and AC 61.

- AC 59: drawn stainless steel housing, only together with cable outlet, no access to control elements
- AC 61: machined housing, possible with cable or bus cover, access to control elements (DIP switch, Reset switch)

TECHNICAL DATA
mechanical

Housing diameter	61.5 mm
Shaft diameter	9.52 mm / 10 mm (Solid shaft)
Flange (Mounting of housing)	Square flange 63.5 mm
Protection class shaft input (EN 60529)	IP67
Protection class housing (EN 60529)	IP67
Shaft load axial / radial	40 N / 60 N
Max. speed	max. 6000 rpm (continuous), max. 10 000 rpm (short term)
Torque	≤ 1 Ncm
Moment of inertia	approx. 20 gcm ²
Vibration resistance (DIN EN 60068-2-6)	100 m/s ² (10 ... 500 Hz)
Shock resistance (DIN EN 60068-2-27)	1000 m/s ² (6 ms)
Operating temperature	-40 °C ... +70 °C
Storage temperature	-40 °C ... +85 °C
Material shaft	Stainless Steel
Material housing	Stainless Steel
Weight	approx. 980 g with 1.5 m cable
Connection	Cable, axial or radial

TECHNICAL DATA
electrical

Supply voltage	DC 10-30 V
Max. current w/o load	250 mA (ST / MT)
Resolution singleturn	10 - 17 Bit
Resolution multiturn	12 Bit
Output code	Binary, Gray
Drives	Clock and Data / RS422

Absolute

SSI programmable

TECHNICAL DATA electrical (continued)

Parametrization	Resolution, Code type, Direction, Output format, Warning, Alarm
Control inputs	Direction, Preset 1, Preset 2
Alarm output	Alarm bit
Status LED	Green = ok, red = alarm

RECOMMENDED DATA TRANSFER RATE bei SSI

The max. data transfer rate depends on the cable length. For Clock / $\overline{\text{Clock}}$ and Data / $\overline{\text{Data}}$ please use twisted pairs. Use shielded cable.

Cable length	Frequency
< 50 m	< 400 kHz
< 100 m	< 300 kHz
< 200 m	< 200 kHz
< 400 m	< 100 kHz

SYNCHRONOUS-SERIAL TRANSFER (SSI)

A clock brush is applied at the SSI interface, causing the encoder data to be serially clocked out. With each new clock brush (min. interval 30 ms) new data is readout. The following main parameters are programmable:

- Preset: Software-Preset and via input/pushbutton settable presets (can be inactivated)
- Offset: Relative shifting of actual encoder value.
- Scaling: The actual value of the encoder is multiplied with the factor < 1 (direct entry, increments per measuring distance or per revolution).
- Direction of rotation: Can be changed via software or input (can be inactivated)

- Output formats SSI: Tree format or standard format (MSB oriented)
- Output code: The choices are Gray or binary code, integer or two's complement representation. Selection of significant bit between 16 and 24 Bit.

In addition, programming of max. 7 status bits is possible:

- up to 4 warning positions
- overspeed
- encoder standstill
- parity
- encoder error
- direction of rotation

PROGRAMMING with SSI

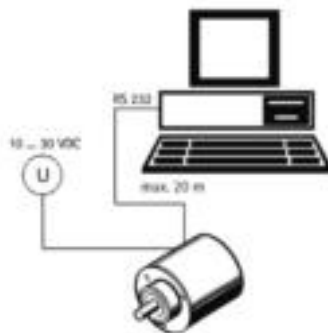

To program the absolute encoder you require a PC, the software WinSSI and the adapter cable.

The encoder is connected to the power supply and the serial interface of your PC with the adapter cable. Using the menu-assisted programme you can then configure the encoder according to the parameters you require.

OUTPUT FORMAT SSI, MSB oriented, Multiturn

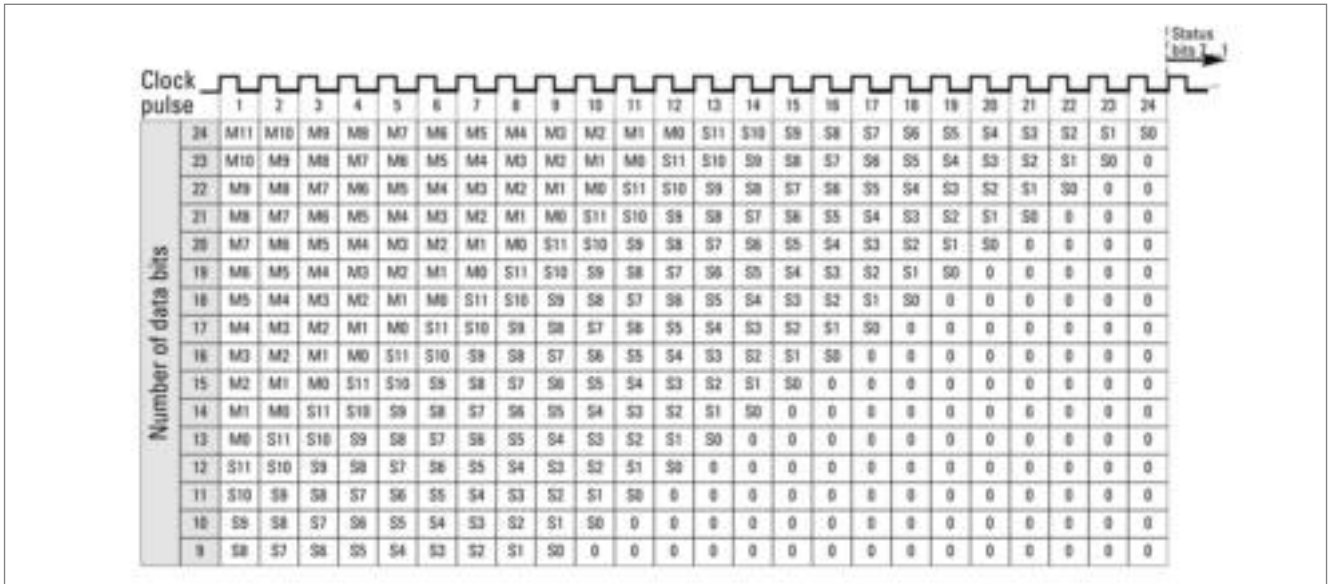

OUTPUT FORMATS SSI, MSB oriented, Multiturn (not scaleable)

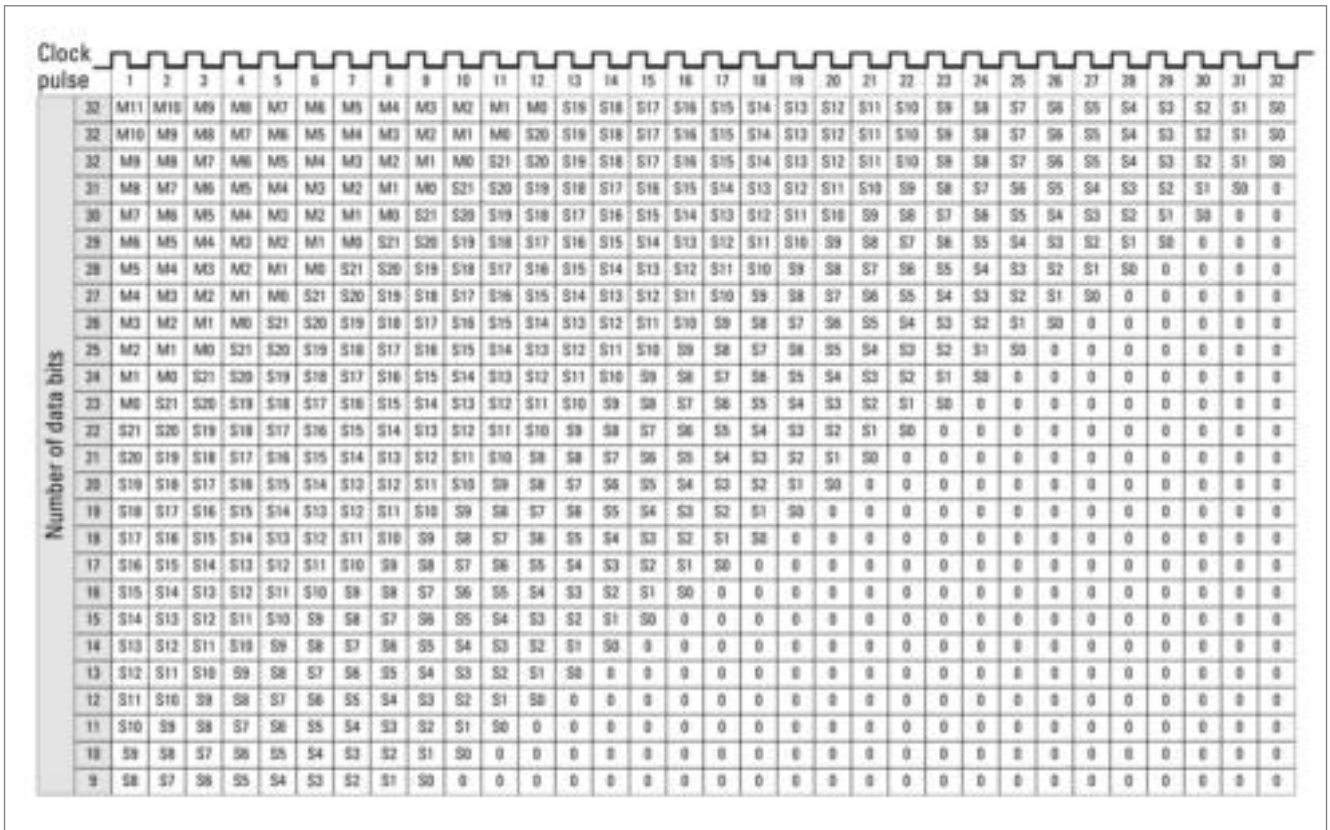

OUTPUT FORMAT SSI, tree format

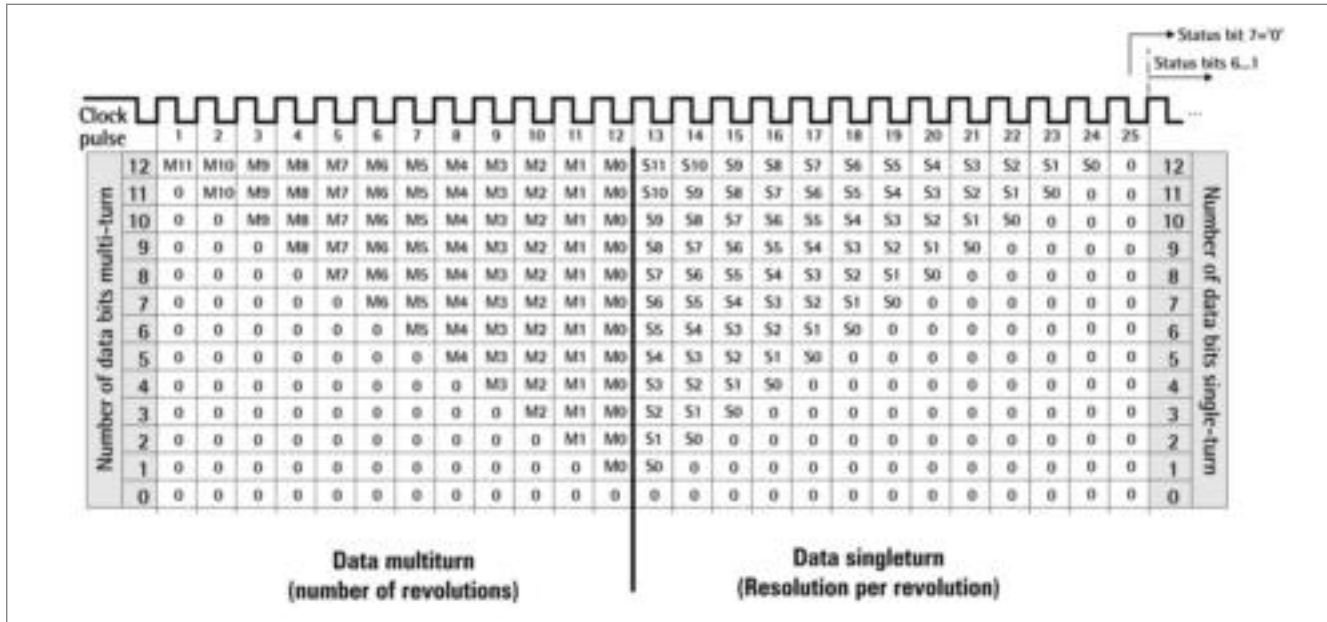

ELECTRICAL CONNECTIONS

12 pole / cable

Cable Colour	Signal
green	Clock
yellow	Clock
pink	Data
grey	Data
brown	RS 232 TxD
white	RS 232 RxD
black	0 V signal output
blue	Direction
red	Preset 1
violet	Preset 2
white ¹	DC 10 - 30 V
brown ¹	0 V (supply voltage)

¹ bigger cross section 0.5 mm²

DIMENSIONED DRAWINGS

see chapter "Dimensioned drawings AC 59 / AC 61", starting page 232

ORDERING INFORMATION

Type	Resolution	Supply voltage	Flange, Protection, Shaft	Interface	Connection
<input type="checkbox"/>	<input type="checkbox"/>	<input type="checkbox"/>	<input type="checkbox"/>	<input type="checkbox"/>	<input type="checkbox"/>
AC61	0010 10 Bit ST 0012 12 Bit ST 0013 13 Bit ST 0014 14 Bit ST 1212 12 Bit MT + 12 Bit ST 1213 12 Bit MT + 13 Bit ST 1214 12 Bit MT + 14 Bit ST 1217 12 Bit MT + 17 Bit ST higher resolution on request	E DC 10 - 30 V	0.76 Square, IP67, 9.52 mm 0.72 Square, IP67, 10 mm	SP SSI programmable	A Cable, axial B Cable, radial

ORDERING INFORMATION

Selection of cable length

Versions with cable outlet (connection A, B, E or F) are available with various lengths of cable. To order your desired cable length, please add the respective code to the end of your ordering code. Further cable lengths on request.

Code	Cable length
without code	1.5 m
-D0	3 m
-F0	5 m
-K0	10 m
-P0	15 m
-U0	20 m
-V0	25 m

ACCESSORIES

see chapter "Accessories", starting page 322

DIMENSIONED DRAWINGS

AC 59 Connection cable "A"/ "B"
Dimensions in mm

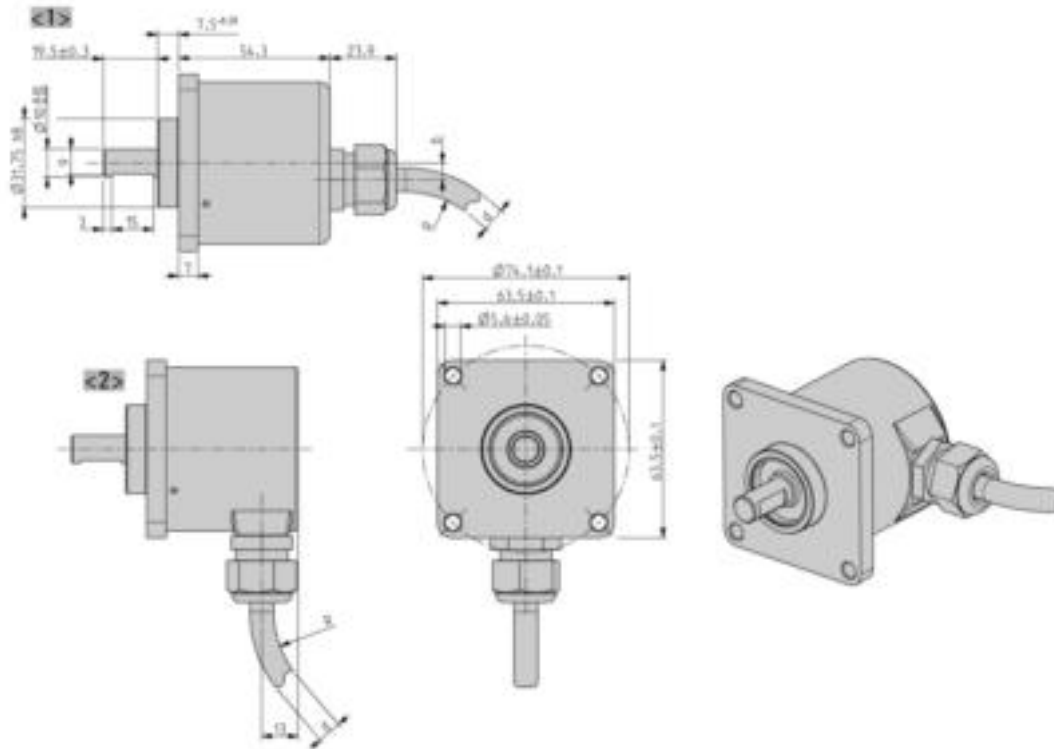

<1> Connection cable "A"

<2> Connection cable "B"

Cable bending radius R for flexible installation $\geq 15 \times$ cable diameter

Cable bending radius R for fixed installation $\geq 7.5 \times$ cable diameter

Cable \emptyset d BiSS/SSI/SSI-P: $7,1^{+1,2}$

Cable \emptyset d ST-P: $7,8^{+0,9}$

DIMENSIONED DRAWINGS (continued)

AC 61 Connection cable "A" Interface: CANopen, CANlayer2

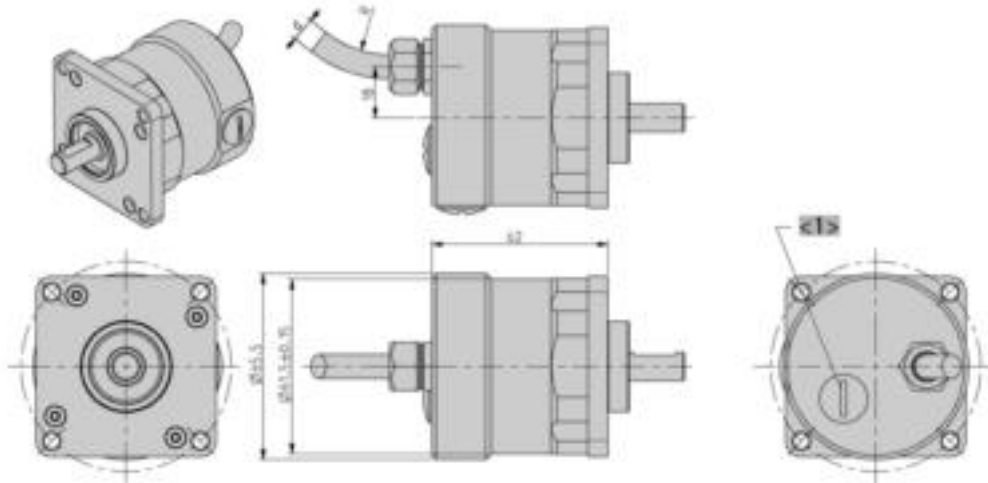

<1> Settings

Cable bending radius R for flexible installation $\geq 15 \times$ cable diameter

Cable bending radius R for fixed installation $\geq 7.5 \times$ cable diameter

Cable \varnothing d BiSS/SSI/SSI-P: $7,1^{+1,2}$

Cable \varnothing d ST-P: $7,8^{+0,9}$

Cable \varnothing d MT-P: $9,3^{+1,3}$

Cable \varnothing d Fieldbus: $7,1^{+1,2}$

Dimensions in mm

AC 61 Connection cable "B"

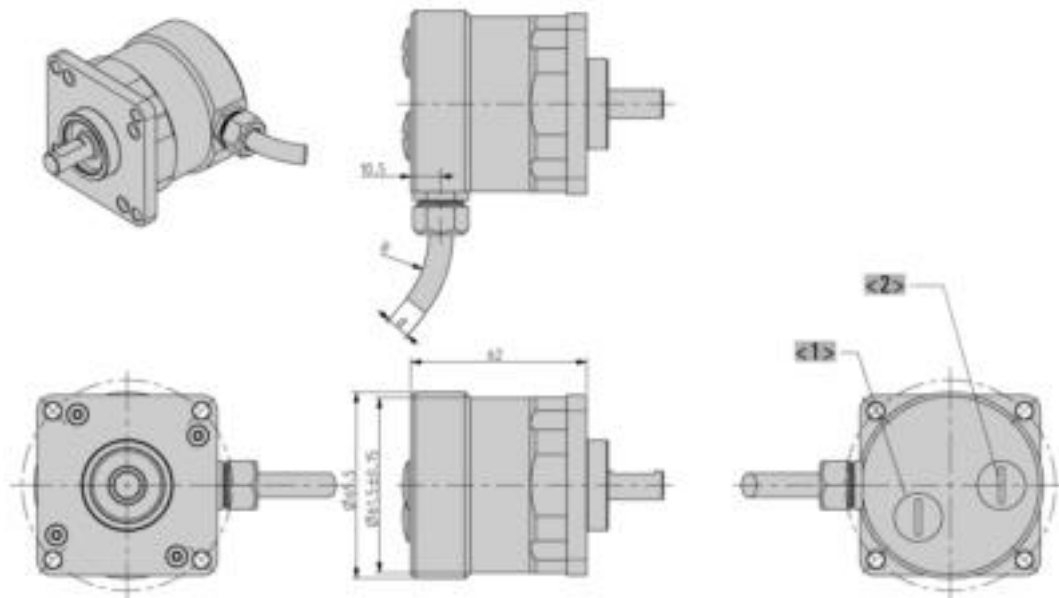

<1> Settings CAN/ CANopen

<2> Preset BiSS, SSI, SSI-P, MT-Parallel

Cable bending radius R for flexible installation $\geq 15 \times$ cable diameter

Cable bending radius R for fixed installation $\geq 7.5 \times$ cable diameter

Cable \varnothing d BiSS/SSI/SSI-P: $7,1^{+1,2}$

Cable \varnothing d ST-P: $7,8^{+0,9}$

Cable \varnothing d MT-P: $9,3^{+1,3}$

Cable \varnothing d Fieldbus: $7,1^{+1,2}$

Dimensions in mm