

A-LAS Series

Laser Analog Light Barriers

Parallel laser light with homogeneous light distribution in round or rectangular cross-section is used for measuring, positioning, and detection of objects starting from a size of 0.01 mm.

- Visible laser beam (laser class 2)
- Apertures available from 0.2 mm to 30 mm
- High reproducibility starting from 0.5 µm
- High analog band width (300 kHz)
- Optics and optics cover made of glass
- Various electronic control units available (partly parameterisable under Windows® via RS232)

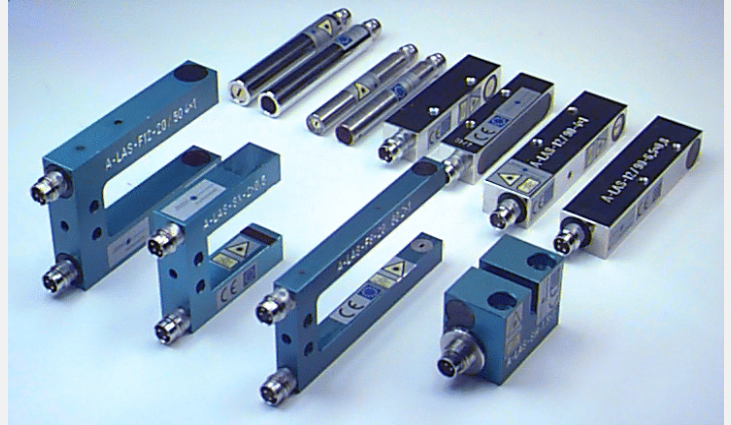

Characteristics

Collimated laser beam

The laser light beam that is emitted by a high-precision optical unit (aspherical surface made of glass) allows the detection of smallest objects (e.g. threads) even in case of a large transmitter/receiver distance (distances up to 5m, depending on the aperture).

Advantages:

- telecentric design
- Exact shadow projection onto the receiver
- The distance of measuring object from the transmitter or receiver has no influence on the measuring signal.

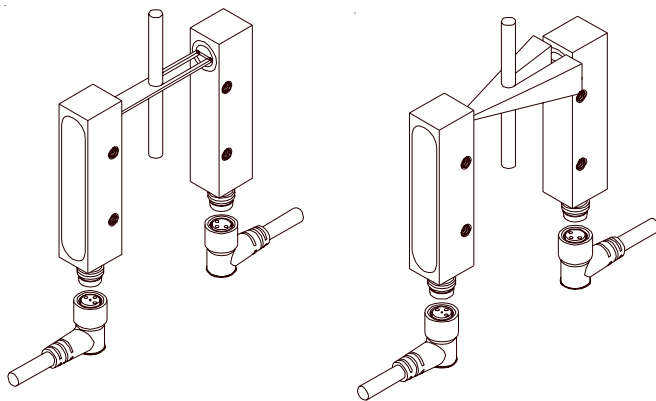

Light barrier of A-LAS Series

Conventional light barrier

Homogeneous light distribution

The use of high-precision apertures in the transmitters ensures optimum adaptation to the respective application. Apart from a large variety of standard apertures special apertures can also be realised. The aperture guarantees a homogeneous light distribution on the beam and a sharp beam limitation.

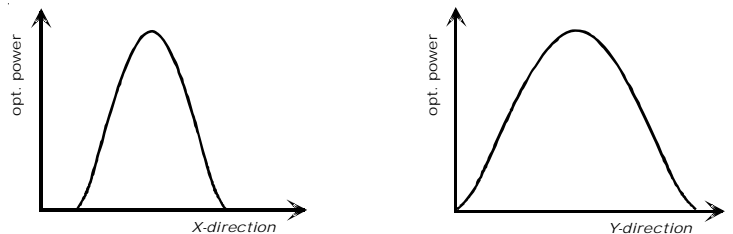

Conventional design: Beam profile in the two main axes

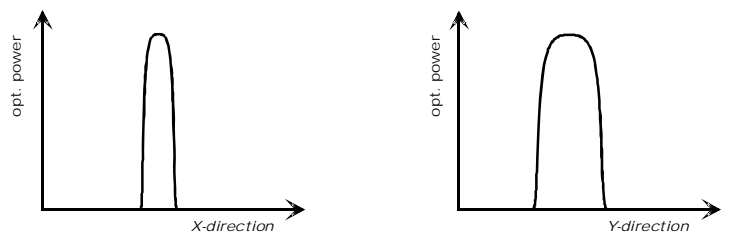

A-LAS Series: Beam profile in the two main axes

Measuring principle

Partial covering of the laser beam leads to a voltage at the analog output that is proportional to the degree of covering.

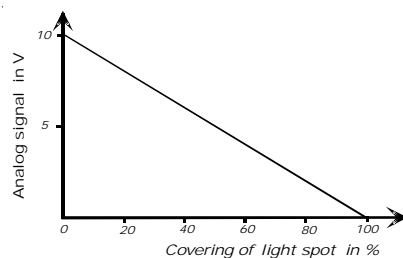

Compact and sturdy metal housing

With their sturdy metal housing and their high type of protection the laser light barriers of series A-LAS are designed for demanding applications in machine construction. With respect to the housing size the A-LAS-90 sensor type with integrated laser driver and pre-amplifier electronics, for example, can be compared with conventional sensor types, and it can be installed and mounted without any problems.



Product Line

Light Barriers

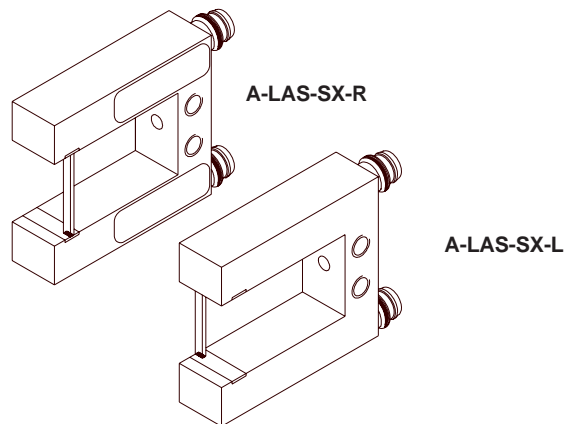
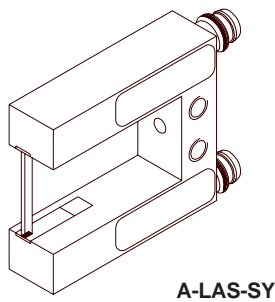
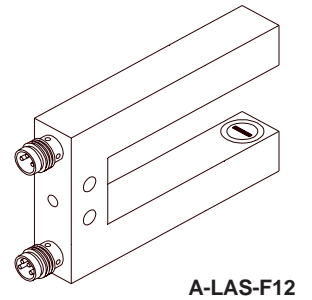
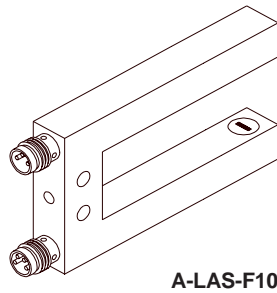
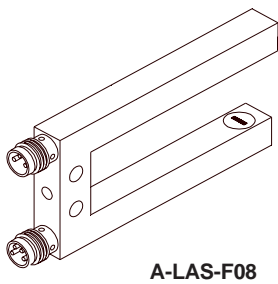
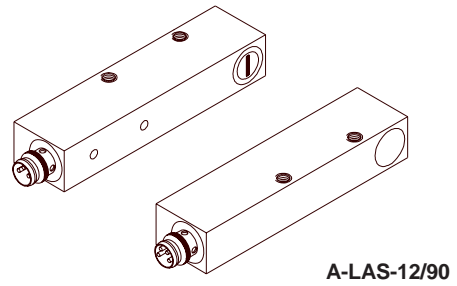
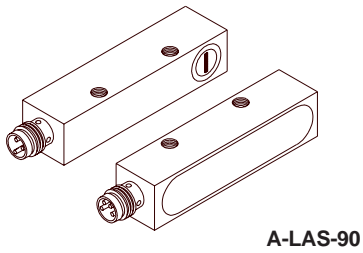
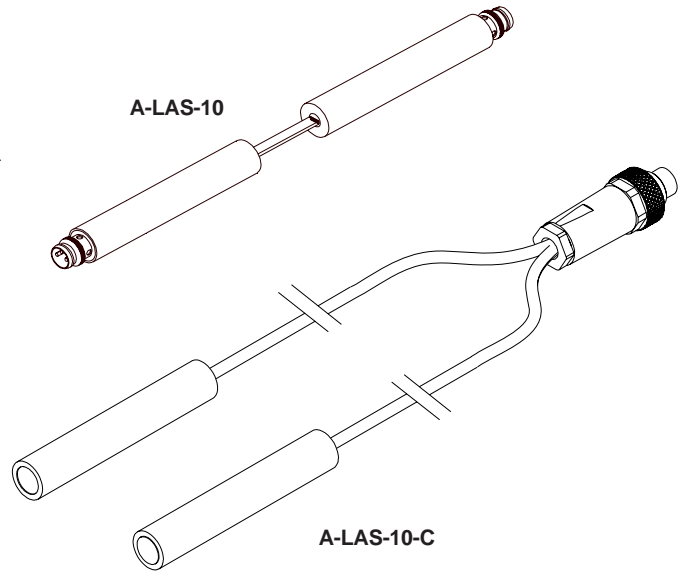
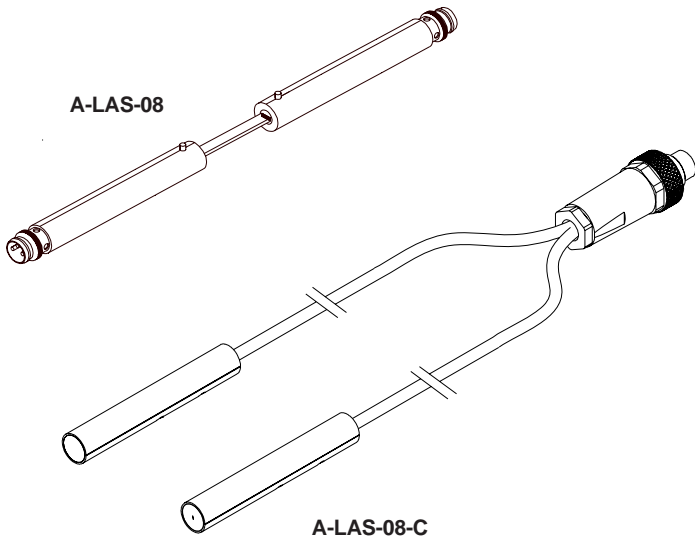



Product Line

Light Barriers

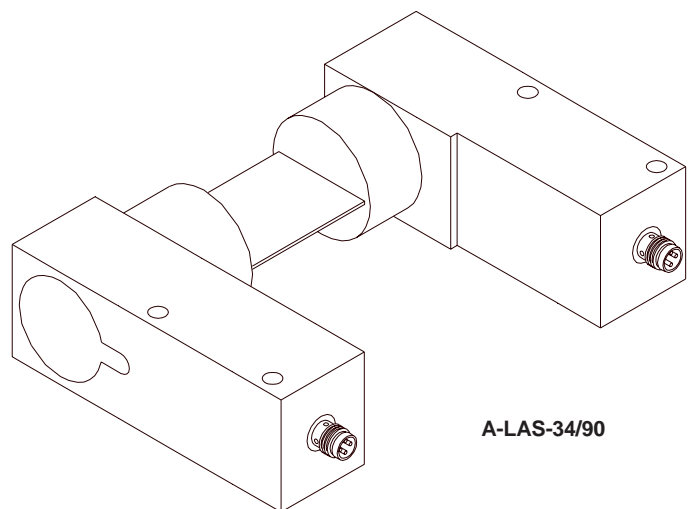
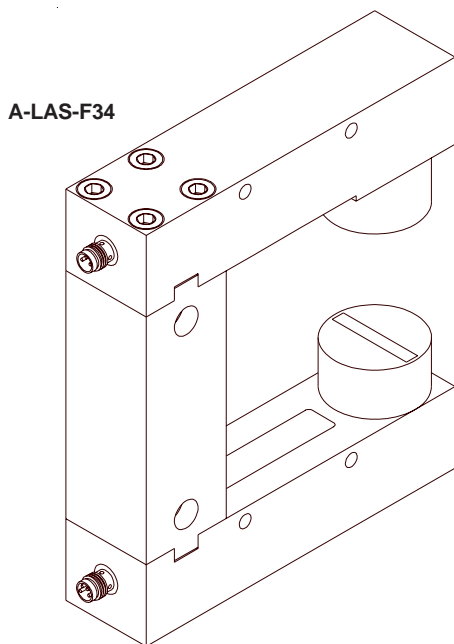
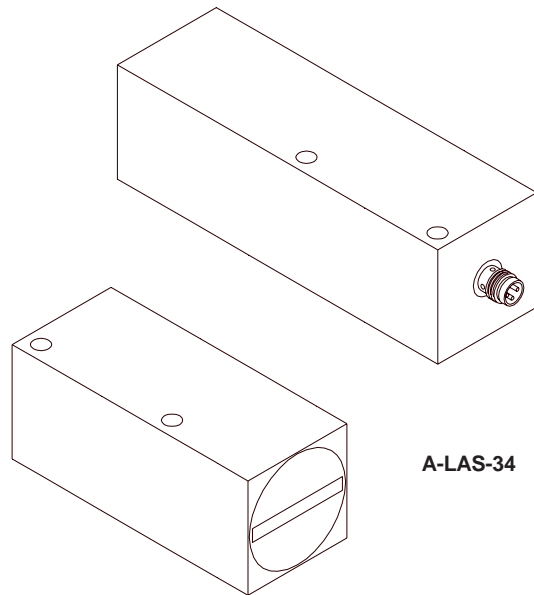
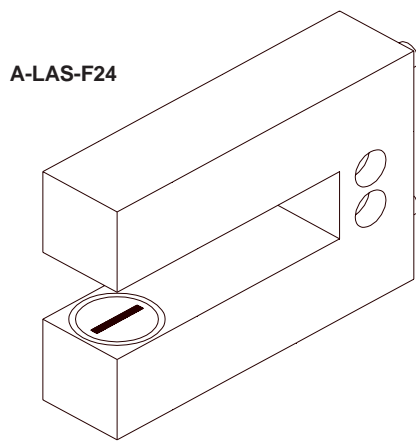
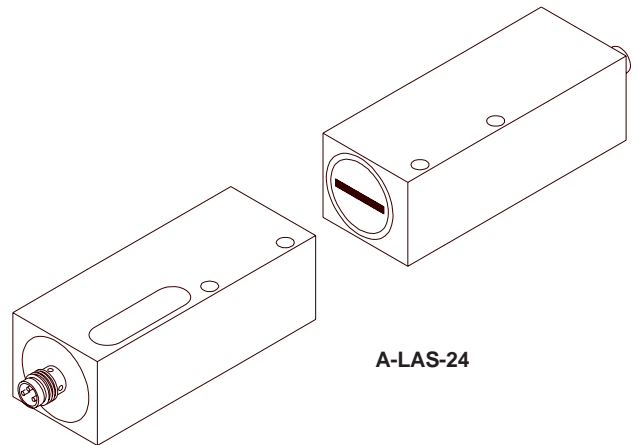
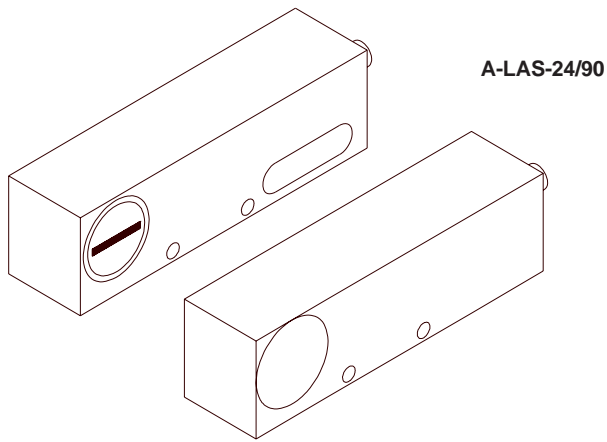

Product Line

Electronic control units

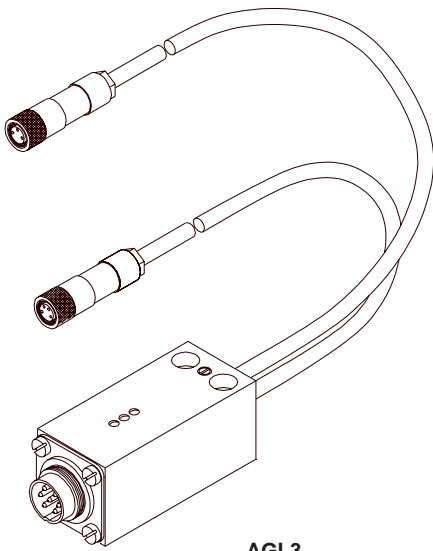

AGL3

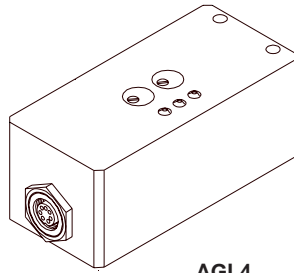

AGL4

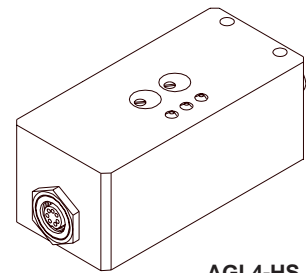

AGL4-HS

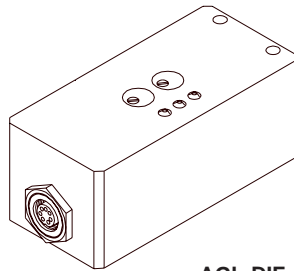

AGL-DIF

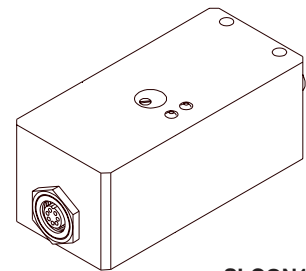

SI-CON11

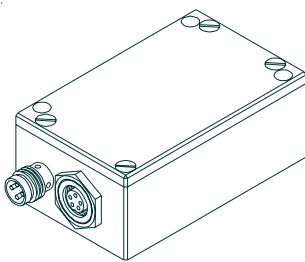

SI-CON4

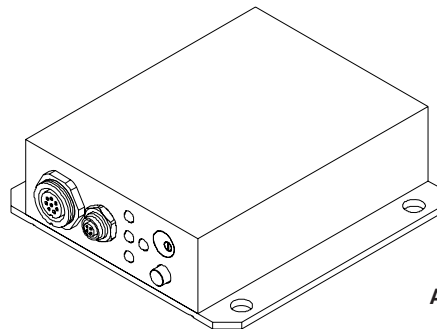

A-LAS-CON1

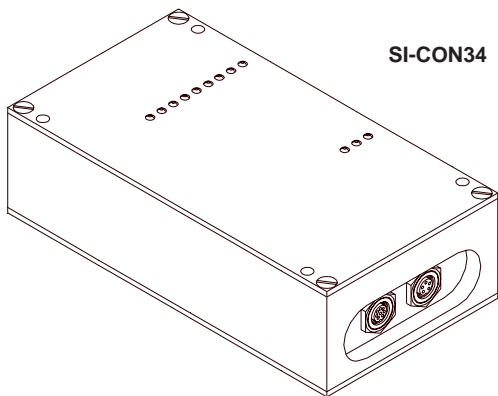

SI-CON34

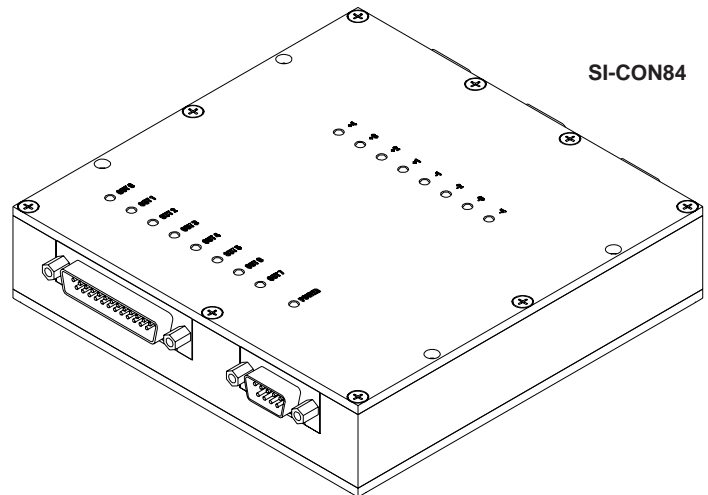

SI-CON84