

D-LAS Series

► **D-LAS-ED1-(9,5)-T** (Glass Pane Detection)
D-LAS-ED1-30°-R

- Insensitive to outside light due to interference filter and absorption filter as well as pulsating light operation (100kHz)
- Adjustment of sensitivity via 5-step switch
- Adjustment of gain via 3-revolutions-potentiometer
- Receiving signal level display via 3 LEDs (yel/grn/yel)
- Dirt accumulation indication via red LED
- Switching state indication via yellow LED
- Highly sensitive (starting from 0.5 mm strength of glass)
- Large transmitter/receiver distance (4 m)
- Large receiver range (laser spot 9,5 mm x 4 mm)
- Inclined glass cover of receiver (additional protection from pollution through glass particulates)
- Analog output (0V ... +10V)



Design

Product name:

Transmitter: D-LAS-ED1-9,5x4-T or D-LAS-ED1-4x9,5-T
Receiver: D-LAS-ED1-30°-R

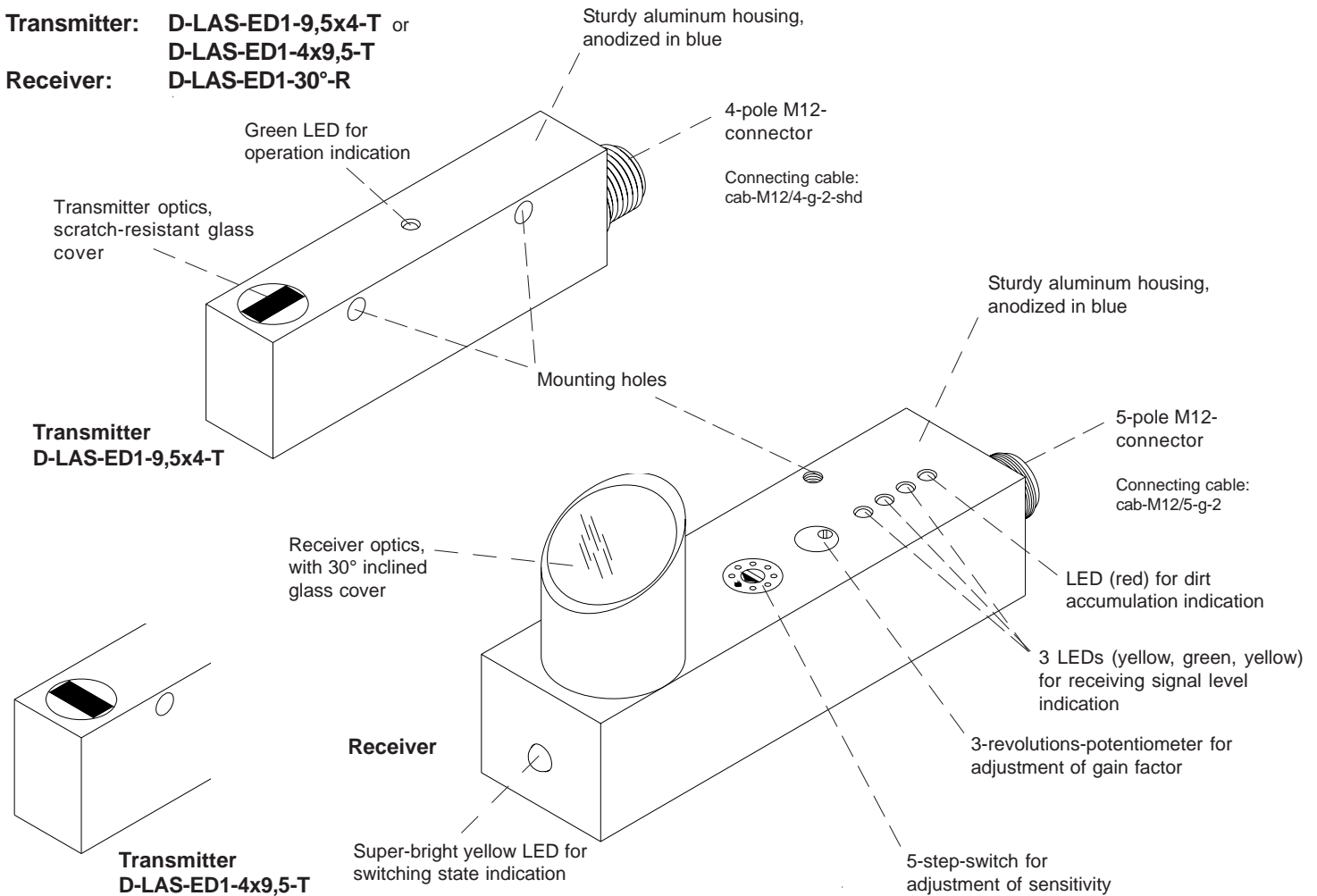



Technical Data

Model	D-LAS-ED1-(9,5)-T and D-LAS-ED1-30-R°
Laser	Solid state laser, 670 nm, 1 mW max. opt. power, class 2 laser product according to DIN EN 60825. The use of these laser transmitters therefore requires no additional protective measures.
Max. range	typ. 4 m
Min. detectable strength of glass	0.5 mm
Beam dimensions at sensor outlet	typ. 9,5 mm x 4 mm
Optical filter	Interference filter + absorption filter (IR filter)
Beam divergency	typ. 1 mrad
Voltage supply	+12VDC ... +32VDC, reverse polarity protection, overload protection
Pulsating light operation/ constant light operation	Pulsating light (100 kHz)
Ambient light	up to 5000 Lux
Adjustment of sensitivity (switching threshold)	adjustable via integrated 5-step switch
Adjustment of gain (analog signal)	adjustable via integrated 3-revolutions potentiometer
Current consumption	Transmitter: typ. 60 mA Receiver: typ. 30 mA
Switching frequency	typ. 1 kHz
Switching outputs	Pin 2 (white): Analog output (0 ... +10V) Pin 4 (black): Output Q _{inv} (npn bright-switching, pnp dark-switching) Pin 5 (grey): Output Q (pnp bright-switching, npn dark-switching)
Enclosure rating	IP67
Operating temperature range	-20°C up to +50°C
Storage temperature range	-20°C up to +85°C
Housing material	Aluminum, anodized in blue
Housing dimensions	Transmitter: approx. 80 mm x 24 mm x 16 mm, receiver: approx. 100 mm x 28 mm x 54 mm
Connector type	Transmitter: 4-pole M12 connector (stainless steel), receiver: 5-pole M12 connector (stainless steel)
Max. switching current	100 mA, short-circuit proof
EMC test acc. to	IEC - 801... 
Switching state indication	by means of a super-bright yellow LED (at receiver)
Dirt accumulation indication	by means of a red LED (at receiver)
Receiving signal level indication	by means of 3 LEDs: yellow/green/yellow (at receiver)
Operation indication	by means of a green LED (at transmitter)



Laser Warning

The transmitters of the laser one-way light barriers of D-LAS Series comply with laser class 2 according to EN 60825. The use of these laser transmitters therefore requires no additional protective measures.

The transmitters of the D-LAS Series are supplied with a laser warning label.

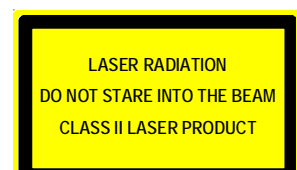



Dimensions

D-LAS-ED1-T
(transmitter):

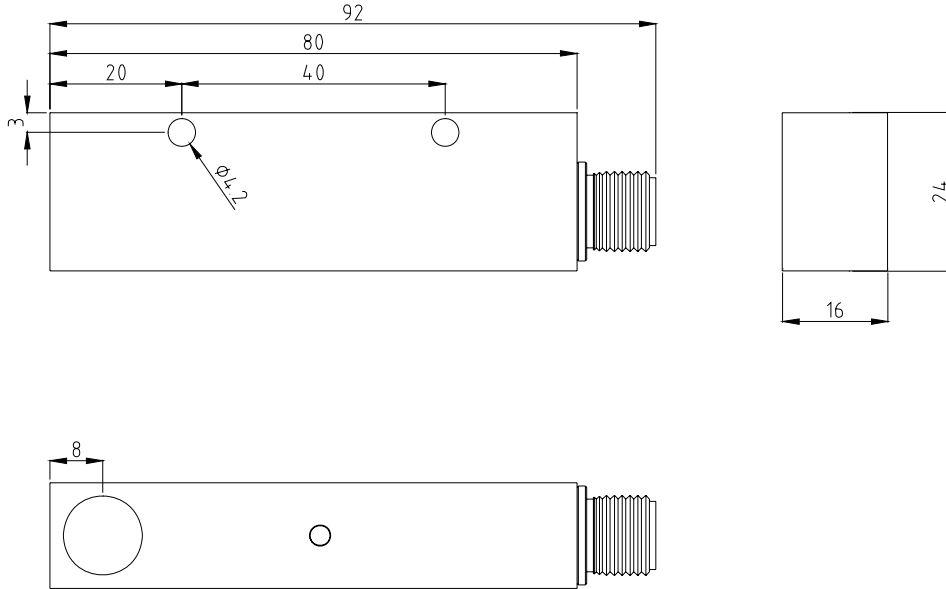

D-LAS-ED1-30°-R
(receiver):

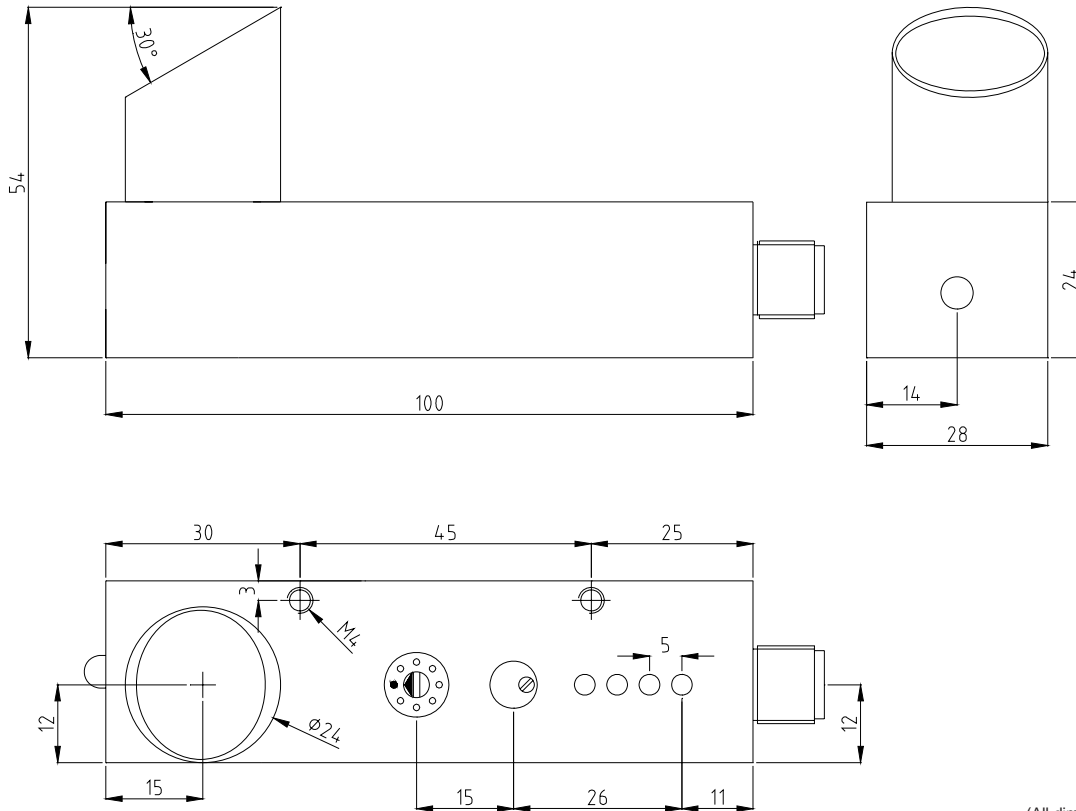

(All dimensions in mm)

Setting

D-LAS-ED1-...-T
(transmitter):

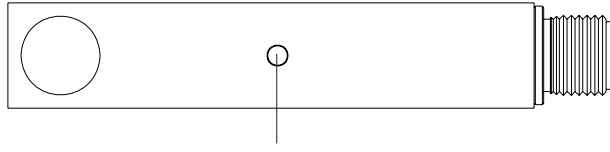

Green LED for operating display

D-LAS-ED1-30°-R
(receiver):

Super bright yellow LED for switching state display

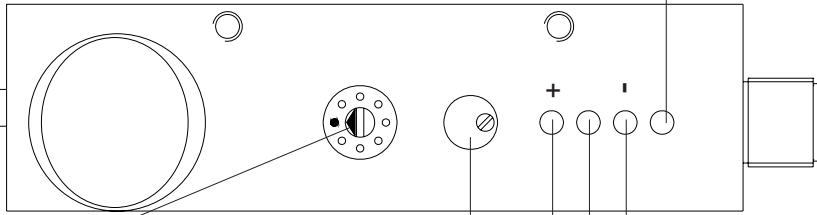

Dirt accumulation indication:
red LED on: sensor dirty

Receiving signal level indication:
yellow LED on: receiving signal too low
green LED on: receiving signal correct
yellow LED on: receiving signal too high (overloaded)

5-step switch for adjustment of sensitivity (switching threshold):
Step 1: 93% (threshold at 93% of receiving signal)
Step 2: 90%
Step 3: 87%
Step 4: 83%
Step 5: 80%

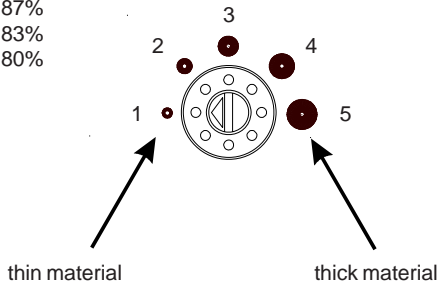

3-revolutions potentiometer for adjustment of gain:
Rotation clockwise:
Receiving level decreases
(decrease of amplification)

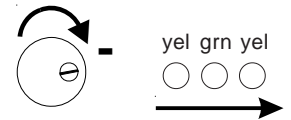

Adjustment of the laser light barrier:

After mounting of transmitter and receiver units, the laser beam can be aligned to the receiver optics by means of the mounting flanges (on-period conditions!). Then, the gain factor of the receiver can be set by means of the potentiometer, the optimal gain is indicated via the green LED.

Connector Assignment

D-LAS-ED1-...-T (transmitter):
4-pole M12 connector

Pin No.:	(Color)	Assignment:
1	(brn)	+Ub (+12 ... +30VDC)
2	(wht)	n.c.
3	(blu)	GND (0V)
4	(blk)	n.c.
Shield	Housing	

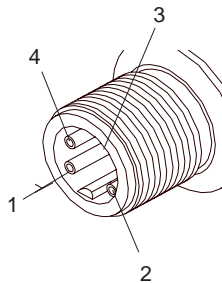

Connecting cable for transmitter:

cab-M12/4-g-2-shd

(PUR-cable, shielded, length 2 m, 4-pin M12 female connector)

D-LAS-ED1-30°-R (receiver):
5-pole M12 connector

Pin No.:	(Color)	Assignment:
1	(brn)	+Ub (+12 ... +30VDC)
2	(wht)	ANALOG (0...+10V)
3	(blu)	GND (0V)
4	(blk)	Output INV „Qinv“
5	(gry)	Output „Q“

Connecting cable for receiver:

cab-M12/5-g-2

(PUR-cable, shielded, length 2 m, 4-pin M12 female connector)

**Application Example**

When flat glass (float glass) is transported, the start and end of a glass pane have to be reliably detected before a change of the direction of transport. It must be ensured in this process that no spurious trigger pulses are initiated while the laser light beam is interrupted by the glass pane. The conveyer belt may have a width of up to 12 m, and it is possible that several glass panes are transported in parallel. It may also be that only one glass pane is transported within these 12 m. In this case it is important that the position of the glass pane is reliably detected, irrespective of its position. Detection also must take into consideration that float glass of a thickness of 0.5 mm may be transported.

For safe detection of the glass pane a correspondingly large detection range (9,5 mm x 4 mm) must be available on the one hand, and on the other hand it must be possible to set a correspondingly high sensitivity.

Sensitivity setting is done in 5 steps by means of a step switch. A potentiometer is used to set the proper gain (3 LEDs as setting aid: 1 x green, 2 x red). The output provides two digital signals (glass detection and dirtying). An additional LED (yellow) provides information about the switching state (glass detection) of the laser light barrier.

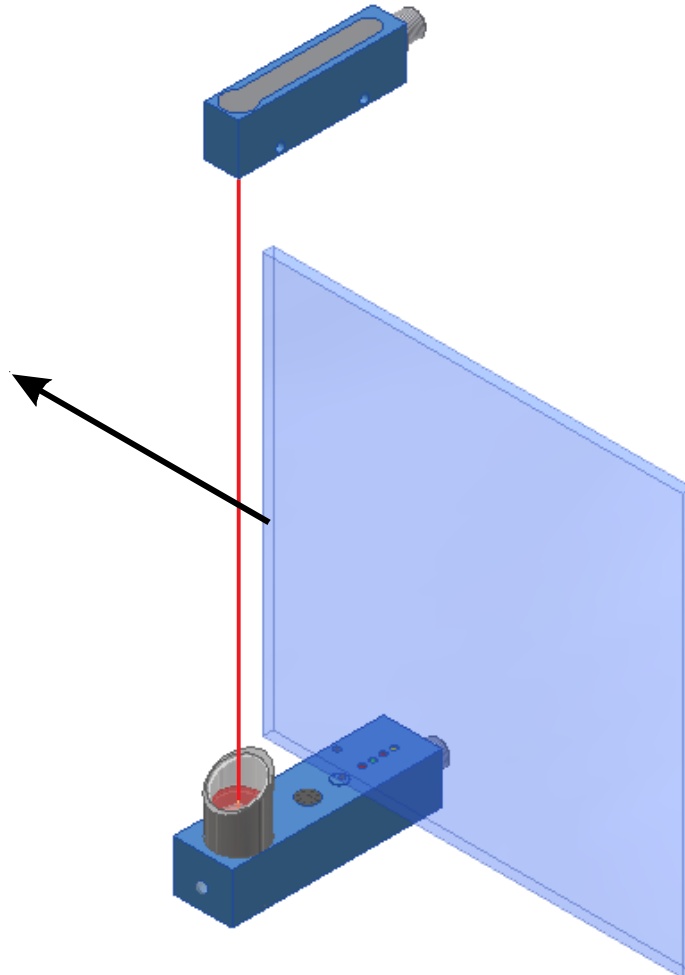



Notes