

D-LAS Series

► D-LAS-34/90

- Optics cover made of glass
- Big measuring range up to 30mm
- Analog output 0V...+10V
- Switching output
- Switching state display via yellow/green-LED
- Sensitivity and amplification adjustable by means of an integrated 3-revolutions potentiometer
- Sturdy housing made of aluminum

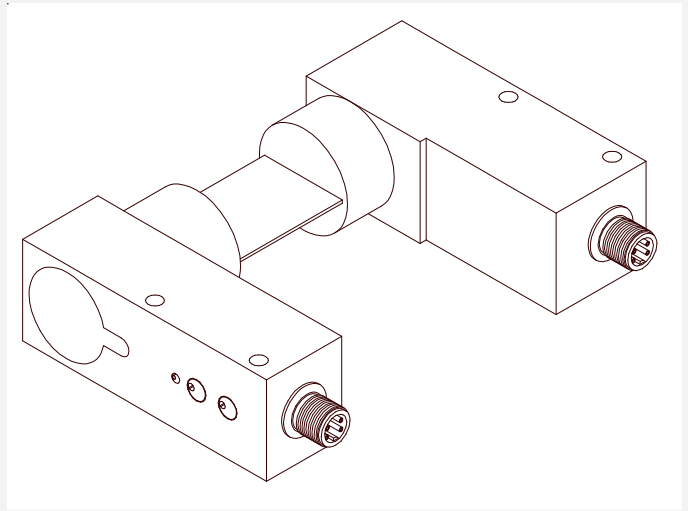

Design

Product name:

Transmitter: D-LAS-34/90-(aperture)*-T

**Receiver: D-LAS-34/90-Q-(aperture)*-R
D-LAS-34/90-Qinv-(aperture)*-R
D-LAS-34/90-TC-Q-(aperture)*-R
D-LAS-34/90-TC-Qinv-(aperture)*-R**

Q = Switching output:
npn dark-switching (npn n.o.)/
pnp bright-switching (pnp n.c.)

Qinv = Switching output:
pnp dark-switching (pnp n.o.)/
npn bright-switching (npn n.c.)

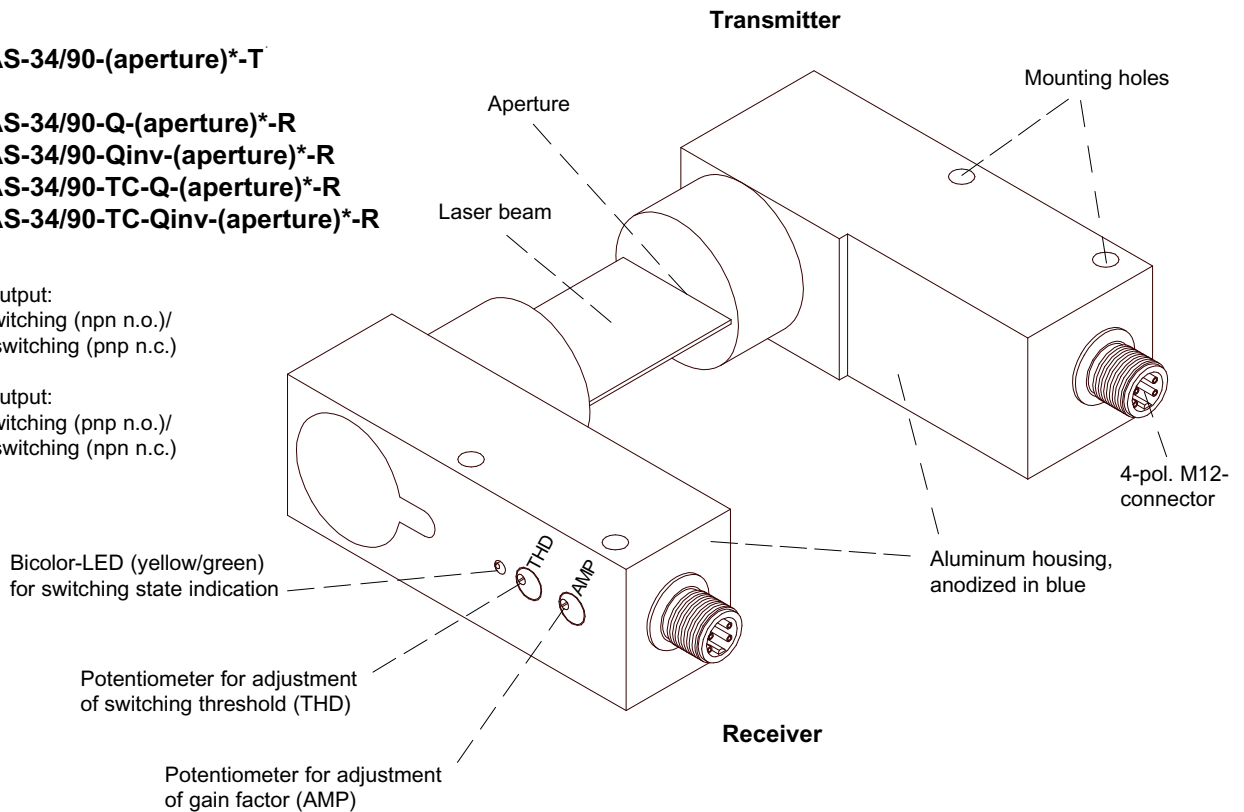

***We recommend aperture combinations for transmitter/receiver as follows:**

Aperture transmitter (AxB in mm):		Aperture receiver (AxB in mm):
30 x 2	and	30 x 0.5
25 x 2	and	25 x 0.3
20 x 2	and	20 x 0.3
10 x 2	and	10 x 0.3
5 x 2	and	5 x 0.3

Aperture orientation:

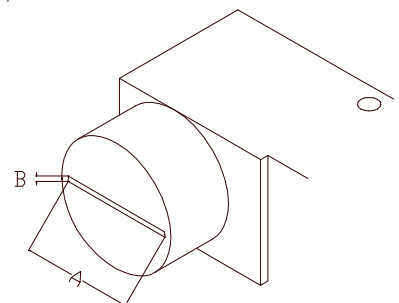



Technical Data

Model	D-LAS-34/90
Laser	Solid state laser, 670 nm, DC-operation, 1 mW max. opt. power, laser class 2 acc. to DIN EN 60825. The use of these laser transmitters therefore requires no additional protective measures.
Max. range	typ. 5 m
Min. detectable object	Analog typ. 1% of aperture size, digital typ. 0.5% of aperture size
Reproducibility	Analog typ. 1% of aperture size, digital typ. 0.5% of aperture size with threshold correction "TC": typ. 0.1% of aperture size
Optical filter	Interference filter + polarisation filter
Threshold correction	With type "TC"
Voltage supply	+12VDC ... +32VDC, protected against polarity reversal, overload protected
Pulsating light/ Direct light operation	DC-operation
Ambient light	Up to 5000 Lux (depending on the aperture used)
Sensitivity setting (switching threshold)	Adjustable by means of an integrated potentiometer (3 revolutions)
Amplifier gain (analog signal)	Adjustable by means of an integrated potentiometer (3 revolutions)
Current consumption	Transmitter: typ. 60 mA Receiver: typ. 30 mA
Available aperture sizes	Transmitter: 30x2, 25x2, 20x2, 10x2, 5x2 (mm) Receiver: 30x0.3, 25x0.3, 20x0.3, 10x0.3, 5x0.3 (mm)
Current control input I-CONTROL	0V...+5V: laser power decreases linearly with increasing voltage + 5V...+32V: laser OFF max. MODULATION/FREQUENCY: 2 kHz
Monitoring output (analog output)	0V...+10V (typ. 100 kHz band width)
Type of protection	IP67
Operating temperature range	-20°C to +50°C
Storage temperature range	-20°C to +85°C
Housing material	Material: Aluminum, anodized in blue
Housing dimensions	Transmitter and receiver: approx. 94 mm x 34 mm x 50 mm
Connector type	M12, 4-polig (plug made of refined steel)
Max. switching current	100 mA, short-circuit-proof
EMC test acc. to	IEC - 801... 
Switching state display	By means of an integrated yellow/green LED
Switching frequency	typ. 25 kHz
Linearity	With aperture 30mm: typ. 3%, with aperture 25mm: typ. 2%, with aperture 10mm: typ. 1%, with aperture 5mm: typ. 0.3%



Laser Warning

The transmitters of the laser one-way light barriers of D-LAS Series comply with laser class 2 according to EN 60825. The use of these laser transmitters therefore requires no additional protective measures.

The transmitters of the D-LAS Series are supplied with a laser warning label.

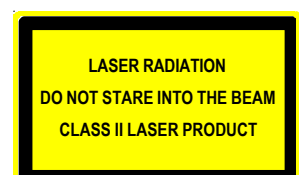

Setting

Adjustment of potentiometers:

Switching state indication:

Gain factor:

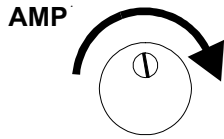

Rotation clockwise:
Gain max.

Switching threshold:

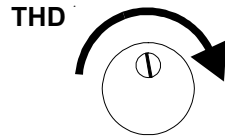

Rotation clockwise:
Threshold max.

Bi-Color-LED:



LED yellow:
Analog voltage < switching threshold
(Crossing the threshold from a higher level to a lower level causes a change of the switching state at the digital output --> LED is switching from green to yellow)



LED green:
Analog voltage > switching threshold

Connector Assignment

Receiver:

(4-pin M12-connector, shielded)

Type Q (npn dark-switching / pnp bright-switching):

Pin No.:	Color:	Assignment:
1	brn	+12VDC...+32VDC
2	wht	ANALOG (0V...+10V)
3	blu	GND (0V)
4	blk	OUTPUT
Shield		Housing

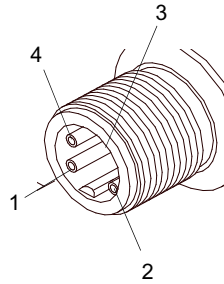

Transmitter:

(4-pin M12-connector, shielded)

Pin No.:	Color:	Assignment:
1	brn	+12VDC...+32VDC
2	wht	I-CONTROL (0...+32V)
3	blu	GND (0V)
4	blk	GND (0V)
Shield		Housing

Type Qinv (pnp dark-switching / npn bright-switching):

Pin No.:	Color:	Assignment:
1	brn	+12VDC...+32VDC
2	wht	ANALOG (0V...+10V)
3	blu	GND (0V)
4	blk	OUTPUT INV
Shield		Housing

Connecting Cables

Available connecting cables:

cab-M12/4-g-2-shd	Length: 2m	Outer jacket: PUR	shielded
cab-M12/4-g-5-shd	Length: 5m	Outer jacket: PUR	shielded
cab-M12/4-w-2-shd	Length: 2m	Outer jacket: PUR	angle-type, shielded
cab-M12/4-w-5-shd	Length: 5m	Outer jacket: PUR	angle-type, shielded

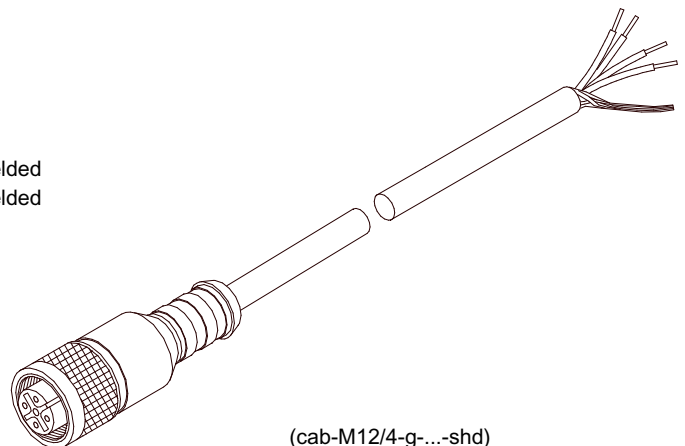

(cab-M12/4-g-...-shd)